

# TURN TUTORIAL

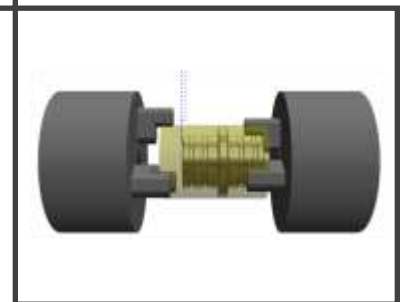
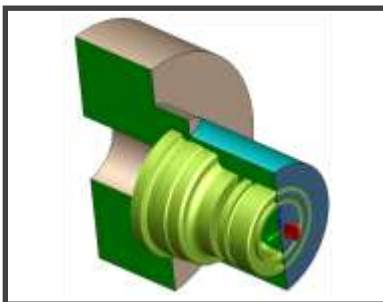
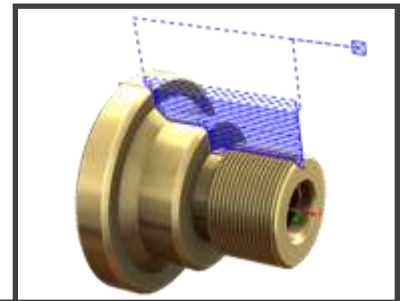
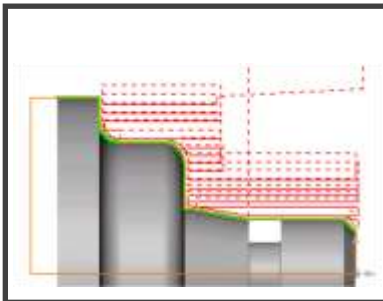

## Copyright

© 1995-2019, Dassault Systemes SolidWorks Corporation, a Dassault Systèmes SE company, 175 Wyman Street, Waltham, Mass. 02451 USA. All Rights Reserved.

## Disclaimers

The information and the software application discussed in this document are subject to change without prior notice and are not commitments by Dassault Systemes SolidWorks Corporation (DS SolidWorks).

No material may be reproduced or transmitted in any form or by any means, electronically or manually, for any purpose without the express written permission of DS SolidWorks.

The software discussed in this document is furnished under a license and may be used or copied only in accordance with the terms of the license. All warranties given by DS SolidWorks as to the software and documentation are set forth in the license agreement, and nothing stated in, or implied by, this document or its contents shall be considered or deemed a modification or amendment of any terms, including warranties, in the license agreement.

## Trademarks

- SOLIDWORKS, 3D ContentCentral, 3D PartStream.NET, eDrawings, and the eDrawings logo are registered trademarks and FeatureManager is a jointly owned registered trademark of DS SolidWorks.
- CircuitWorks, FloXpress, PhotoView 360, and TolAnalyst are trademarks of DS SolidWorks.
- FeatureWorks is a registered trademark of Geometric Americas, Inc.
- Adobe, the Adobe logo, Acrobat, the Adobe PDF logo, Distiller and Reader are registered trademarks or trademarks of Adobe Systems Inc. in the U.S. and other countries.
- Other brand or product names are trademarks or registered trademarks of their respective holders.



The **3DEXPERIENCE**® Company

**Product Name: SOLIDWORKS CAM 2019**

# Table of Contents

<b>CHAPTER 1: LEARNING 2 AXIS TURN</b>	<b>7</b>
<b>Turn 1</b>	<b>8</b>
Steps to Generate Turn Toolpaths and NC Code	8
Step 1: Model Part in SOLIDWORKS or Import Part	9
Viewing the FeatureManager Design Trees	10
Step 2: Change to SOLIDWORKS CAM Feature Tree	10
Changing default machine in TechDB	10
SOLIDWORKS CAM Machining Trees	11
SOLIDWORKS CAM Menu and SOLIDWORKS CAM NC Manager	12
SOLIDWORKS CAM Command Manager	12
SOLIDWORKS CAM Options	13
Step 3: Define the Machine	13
Step 4: Edit the Stock Definition	18
Step 5: Define Machinable Features	20
Using Automatic Feature Recognition (AFR)	20
Defining Machinable Features Automatically	21
Defining Features Interactively (IFR)	24
Step 6: Generate Operation Plan and Adjust Operation Parameters	27
Step 7: Generate Toolpaths	30
Step 8: Simulate Toolpaths	31
Change the Machining Order	34
Step 9: Post Process Toolpaths	34
Setup Sheets	36
<b>Turn 2</b>	<b>37</b>
Turn Feature Types Recognized by AFR and IFR	37
Supported Turn Feature Types	37
Step 1: Open the Part	38
Step 2: Defining the Machine and Editing the Stock Definition	38
Define the Machine	38
Editing the Tool Crib	39
Selecting the Post Processor	42
Editing the Stock Definition	43
Step 3: Extracting Machinable Features and Editing Feature Parameters	43
Extracting Machinable Features	43
Feature Strategy	44
Step 4: Generating Operations	46
Step 5: Generating NC Code	48
<b>Turn 3</b>	<b>49</b>
Step 1: Open the Part, Define the Machine, Edit the Stock Definition and Extract Machinable Features	49



Define the Machine Parameters .....	49
Editing the Stock Definition .....	50
Extract machinable Features .....	50
Step 2: Interactively Inserting an OD Profile for Threading.....	50
Step 3: Reorganizing Machinable Features.....	52
Step 4: Suppressing Machinable Features.....	53
Step 5: Saving the File.....	53
Step 6: Generating an Operation Plan and Toolpaths .....	53
SOLIDWORKS CAM Message Window .....	54
Step 7: Simulate Toolpaths.....	55
Viewing XZ cutter coordinates of the Tool in SOLIDWORKS CAM Message Window .....	55
Step 8: Post Processing Toolpaths.....	57
<b>Turn 4 .....</b>	<b>58</b>
Step 1: Open the Part and Define the Machine .....	58
Step 2: Defining the Stock as a Forging or Casting .....	59
Step 3: Recognizing Machinable Features using AFR.....	59
Deleting Unwanted Features Recognized by AFR .....	60
Step 4: Defining a Rectangular OD Groove Feature Interactively .....	60
Step 5: Deleting an Operation .....	62
Step 6: Adjusting Operation Parameters .....	62
Step 7: Displaying the Chuck in Graphics Area.....	63
Step 8: Defining Program Zero .....	63
Step 9: Simulate Toolpath .....	65
Step 9: Post Processing Toolpaths.....	66
<b>Turn 5 .....</b>	<b>67</b>
Step 1: Opening the Part and Defining the Machine and Stock.....	67
Open the Part.....	67
Define the Machine Parameters .....	67
Defining the Stock .....	68
Step 2: Extract Machinable Features.....	68
Deleting Features .....	69
Step 3: Adding an ID Groove Feature Interactively .....	69
Step 4: Adding OD Thread and ID Thread Features Interactively .....	70
Interactively Inserting a Threaded OD Feature .....	71
Interactively Inserting a Threaded ID Feature .....	73
Step 5: Changing Feature Parameters, Generating Operations and Modifying Operation Parameters .....	75
Changing Feature Parameters and Renaming Features .....	75
Generating Operations .....	75
Modifying Operation Parameters.....	76
Step 6: Defining the Machining Sequence and Generating Toolpaths .....	77
Step 7: Displaying the Chuck/Fixture .....	78
Step 8: Defining the Chuck/Fixture.....	79
Step 9: Defining the Chuck Location .....	81
Step 10: Simulate Toolpath .....	83

Step 11: Post Processing Toolpaths.....	83
<b>Turn 6 .....</b>	<b>84</b>
Step 1: Opening the Part.....	84
Step 2: Defining Machine Parameters .....	84
Step 3: Establishing Part Zero .....	85
Step 4: Defining the Stock from a Sketch for Double Chucking .....	87
Step 5: Defining Machinable Features .....	87
Changing Feature Definitions for OD and ID Profiles .....	88
Step 6: Changing the Origin Machining Direction .....	90
Step 7: Generating Operations and Editing Operation Parameters .....	91
Step 8: Defining the Chuck Configuration.....	92
Step 9: Setting the Chuck Display State.....	93
Step 10: Setting the Chuck Location .....	95
Step 11: Simulating the Toolpaths for Double Chucking .....	96
Step 12: Post Processing Toolpaths.....	96
<b>Turn 7 .....</b>	<b>97</b>
Step 1: Opening the Part and Defining the Machining Parameters.....	98
Defining Machining Parameters .....	98
Step 2: Extracting Machinable Features using Plane Section Method.....	99
Setting the Method for AFR .....	99
Extracting Machinable Features .....	99
Step 3: Using the Plane Section to Extract Machinable Features Correctly .....	99
Viewing the Feature Relative to the Standard Orientation .....	102
<b>Turn 8 .....</b>	<b>104</b>
Step 1: Open the Part and Defining the Machine Parameters .....	104
Step 2: Defining a Thread Feature .....	105
Step 3: Cutting Multiple Start Threads.....	107
Step 4: Enabling the ‘Process by Level’ Option for a Threading Operation .....	108
Step 5: Step Through Toolpath .....	108
Step 6: Simulating the Threading Toolpath .....	109
<b>Turn 9 .....</b>	<b>111</b>
Step 1: Opening the Part.....	111
Step 2: Define the Machine Parameters .....	112
Step 3: Defining the Stock.....	113
Step 4: Defining Features Automatically and Interactively .....	114
Step 5: Editing Machinable Features.....	115
Extends of the OD feature.....	115
Extends of the ID feature .....	116
Interactively inserting Face Feature and OD Feature in Turn Setup2 .....	116
Step 6: Generating Operations and Toolpaths.....	118
Step 7: Defining the Chuck Location for Turn Setup1 .....	122
Disabling Chuck/Fixture Display in Graphics Area .....	122
Defining the Geometry of the chuck.....	122
Step 8: Defining the Chuck Location for Turn Setup2 .....	123



---

Step 9: Simulating the Toolpaths for Multiple Turn Setups ..... 126

---

## Chapter 1: Learning 2 Axis Turn

---

This chapter provides an opportunity to learn SOLIDWORKS CAM 2 Axis Turn through a step by step hands-on tour of the features and functions.

The tutorials in this chapter are intended to show you how to use SOLIDWORKS CAM and may not correspond to actual machining practices.

The exercise parts are installed when you install SOLIDWORKS CAM and are in the *\SOLIDWORKS\SOLIDWORKS 201x\CAM Examples\Tutorial\_Parts\Turn* folder.

Typical location: *C:\Users\Public\Public Documents\SOLIDWORKS\SOLIDWORKS 201x\CAM Examples\Tutorial\_Parts\Turn*

---

**IMPORTANT!** SOLIDWORKS CAM uses a set of knowledge-based rules to assign machining operations to features. The Technology Database contains the data for the machining process plans and can be customized for your facility's machining methodology. When you do these exercises, your results may not be exactly the same as described in the steps and illustrated in the figures. This is because the machining sequences and operations data in your Technology Database may be different from the database used to produce the documentation.

---

## Turn 1

### Steps to Generate Turn Toolpaths and NC Code

The following steps are used to generate Turn toolpaths and NC code:

1. Model the part or open the part file in SOLIDWORKS.
2. Click on the SOLIDWORKS CAM Feature tree.
3. Define the Machine and modify the post processor parameters.
4. Edit the Stock definition.
5. Define machinable features and adjust feature parameters.
6. Generate the operation plan and adjust operation parameters.
7. Generate toolpaths.
8. Simulate Material Removal.
9. Post process the toolpaths.

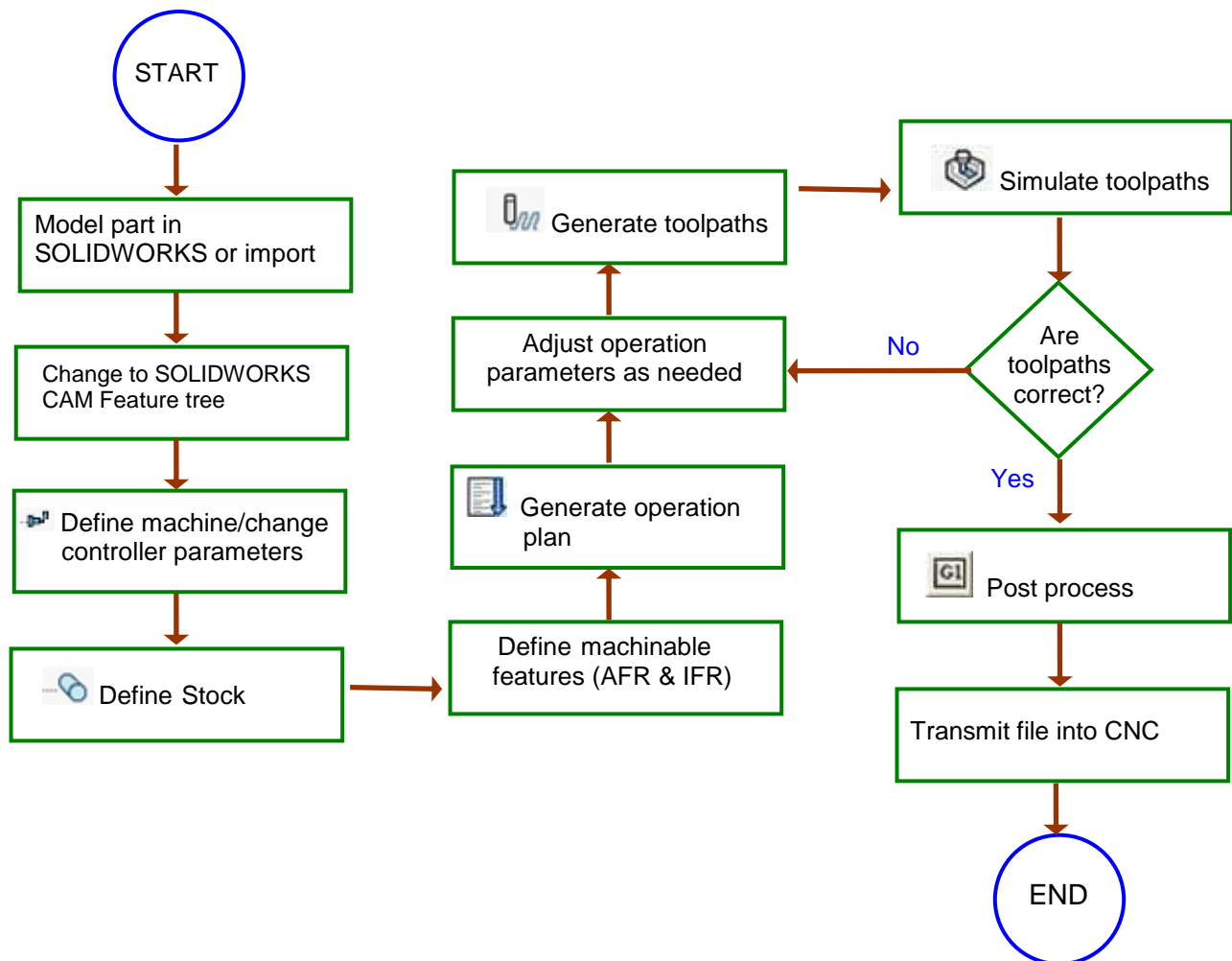



The following series of tutorials show you how to generate finish toolpaths on a SOLIDWORKS part model. In order to give you a general understanding Of how to use SOLIDWORKS CAM, you work with a part that was previously modeled in SOLIDWORKS. When you define the operations and toolpaths, you will follow steps that are not explained in depth. This is done to show you the basics of generating toolpaths from start to finish without getting into the details at this time.

Sample parts are provided for the tutorials in this manual. When you install SOLIDWORKS CAM, these files are installed automatically.

## Topics covered in this tutorial:

- Using the [SOLIDWORKS CAM Command Manager](#) to execute commands
- [Editing the Machine Definition](#)
- [Editing the Stock Definition](#)
- Changing Default Settings using [Options dialog box](#)
- Using the SOLIDWORKS CAM [Feature Tree](#) and [Operation Tree](#)
- [Defining Machinable Features Automatically](#)
- [Interactively inserting an OD Feature](#)
- [Generating Toolpaths](#)
- [Simulate Toolpaths](#)
- [Post Process Toolpaths](#)

## Step 1: Model Part in SOLIDWORKS or Import Part

A part is a solid that is created with SOLIDWORKS or imported into SOLIDWORKS from another CAD system via an IGES, Parasolid, SAT file, etc. This tutorial uses an existing SOLIDWORKS part.

Open the part file **TURN2AX\_1.SLDPRT** in the following folder.

*C:\Users\Public\Public  
Documents\SOLIDWORKS\SOLIDWORKS  
201x\CAM Examples\Tutorial\_Parts\Turn*

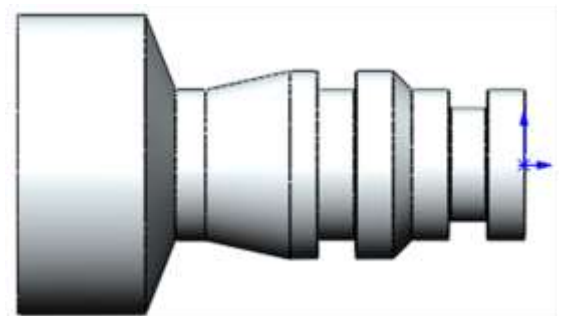

**TURN2AX\_1.SLDPRT**

## Viewing the FeatureManager Design Trees

The FeatureManager design tree  displays the list of the features, sketches, planes and axes related to the part.

To use SOLIDWORKS CAM, you need to move between SOLIDWORKS trees and the SOLIDWORKS CAM Feature trees. Different tabs are provided to access the SOLIDWORKS trees and the SOLIDWORKS CAM Feature trees. Click the  *Pin* button to continuously view this Tree area.

If the SOLIDWORKS CAM tabs [] are not visible, you can expand the size of the tree. Position the cursor on the line that divides the tree area from the graphics area. When the cursor changes to a bar, drag the bar to the right until the tabs display.

## Step 2: Change to SOLIDWORKS CAM Feature Tree

 Click the *SOLIDWORKS CAM Feature Tree* tab.

When the SOLIDWORKS CAM Feature tree is displayed, it initially lists *Configurations*, *Stock Manager*, *Machine* and *Recycle Bin* items.

 The icons that display for the 'Stock Manager' and 'Machine' are indicative of the machine which is currently selected. [Step 3 of this tutorial](#) explains how to select a turn machine.



SOLIDWORKS  
CAM Feature

If you work mainly with turn parts, you can set the default to *Turn* in the TechDB so that SOLIDWORKS CAM will select a Turn machine and stock whenever you open part files.

## Changing default machine in TechDB

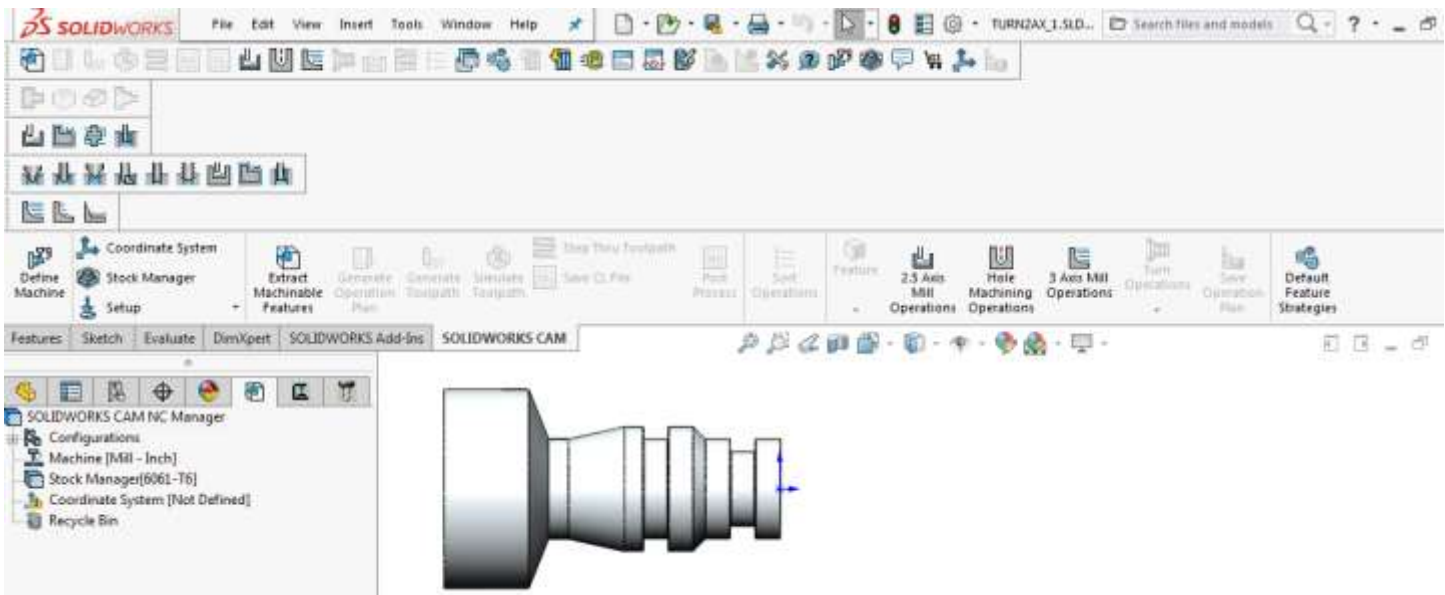

To change the default machine in the TechDB:

Click the *TechDB* button  on the SOLIDWORKS CAM Command Manager. Alternatively, click on the SOLIDWORKS CAM menu and select 'Technology Database' from the dropdown list. Once the Technology Database is launched, under its navigation tree in the Technology Database – Main Menu window, change the Appln default to *Turn* and then click *Exit*. When you open a part file, SOLIDWORKS CAM will select a Turn machine by default.



## SOLIDWORKS CAM Machining Trees

The SOLIDWORKS CAM machining trees provide an outline view of the machining information for the model. Initially, the SOLIDWORKS CAM Feature tree shows only the NC Manager, Configurations, Stock Manager, Machine and Recycle Bin items. As you follow the steps to generate an NC program, this tree expands to include Turn Setups and machinable features. The tabs are for moving between the SOLIDWORKS trees and the SOLIDWORKS CAM trees.

-  **Configurations**  
 Multiple SOLIDWORKS CAM datasets are supported. Each dataset is called a configuration. You can use configurations to support multiple machines and SOLIDWORKS configurations.
-  **Stock Manager**  
 The turn stock is the material from which the part will be machined. You can define the stock as a cylinder (for bar stock) or as a closed sketch (for a forging or casting) and specify the type of material.

- **Machine**

 **Turn**     **Mill**

The Machine item defines the machine tool that will be used to machine the part. The machine definition includes tool definitions and the post processor. These machines are set up in the Technology Database.

-  **Recycle Bin**

The Recycle Bin is used to store machinable features that you do not intend to machine.

### **SOLIDWORKS CAM Menu and SOLIDWORKS CAM NC Manager**

1. Click *Tools* on the SOLIDWORKS menu bar and select *SOLIDWORKS CAM* from the dropdown menu.
2. The SOLIDWORKS CAM NC Manager item is present in both the Feature tree and the Operation tree. Right click on the *SOLIDWORKS CAM NC Manager* in the tree. A list of executable commands is displayed on the context menu. These right-click context menus provide access to a variety of commands. The commands displayed on the context menu for *SOLIDWORKS CAM NC Manager* item in the Feature tree is different from that in the Operation tree.
3. Refer the SOLIDWORKS CAM context-based Help for detailed explanation of the SOLIDWORKS CAM commands and functionalities.

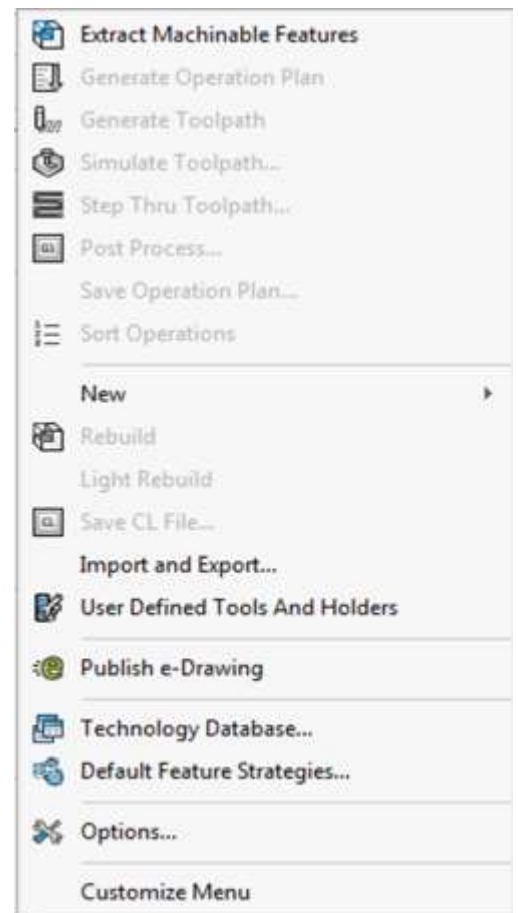

**SOLIDWORKS CAM Menu**

### **SOLIDWORKS CAM Command Manager**

Click *Tools* on the SOLIDWORKS menu bar and select *SOLIDWORKS CAM* from the dropdown menu. This action displays the SOLIDWORKS CAM Command Manager. The SOLIDWORKS CAM Command Manager provides access to the main SOLIDWORKS CAM commands. The commands are explained in the SOLIDWORKS CAM context-based Help.



**SOLIDWORKS CAM Command Manager**

## Customization of SOLIDWORKS CAM Command Manager

Command Manager is a context-sensitive toolbar that can be dynamically updated based on the toolbar you want to access. It provides access to the main SOLIDWORKS CAM commands found on the SOLIDWORKS CAM menu. By default, it has toolbars embedded in it.

The SOLIDWORKS CAM Command Manager can be customized. Right click anywhere on the SOLIDWORKS CAM Command Manager and select *Customize* from the RMB context menu. The *Customize* dialog box will be displayed. Use the *Toolbars*, *Commands*, *Menus*, *Keyboard shortcut*, *Mouse gesture and Options* tab of this dialog box to customize the Command Manager as per your requirements.

## Alternative Access to SOLIDWORKS CAM Commands

All the commands executed from the SOLIDWORKS CAM Command Manager can also be alternatively accessed from the RMB context menu of the SOLIDWORKS CAM NC Manager. This is a context menu. To execute the command, right click on the SOLIDWORKS CAM NC Manager item in the tree and select the desired command from the RMB context menu. In addition to the Command Manager commands, this context menu also provides access to a variety of commands.

## SOLIDWORKS CAM Options

-  Click the SOLIDWORKS CAM *Options* button on the SOLIDWORKS CAM Command Manager. OR  
Click *Tools* on the SOLIDWORKS menu bar and select *SOLIDWORKS CAM* from the dropdown menu.



**Options button on the SOLIDWORKS CAM Command Manager**

The Options dialog box is displayed. This dialog box contains various tabs to customize settings and options related to Saving data, Turn Features, Display, Simulation, Update and File locations.

- Click on each different tab in this dialog box and click the *Help* button. Each tab is explained in the context-based Help.
-  To close the context-based Help, click the *Close* button in the upper right corner of the Help window to close the window.
- Click *OK/Cancel* to close the *Options* dialog box.

## Step 3: Define the Machine

The machine definition specifies the type of machining that will be done for the current model and the associated machine tool control (post processor) for proper generation of the NC program. Based on the selected machine, the *Extract Machinable Features* command will recognize mill, turn features. The machine can be changed to produce NC code for an

alternate machine tool of the same type. The icons that display in the tree identify the machine:



1. Right click the *Machine* item in the SOLIDWORKS CAM Feature tree and select the *Edit Definition* from the context menu.

OR

Double click the *Machine* item in the Feature tree to edit the machine definition.

The *Machine* dialog box is displayed.

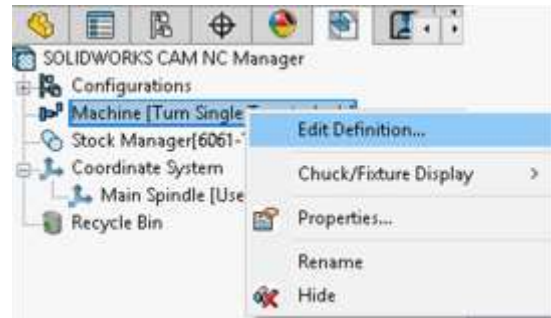

Select 'Edit Definition' on the context menu



### Did You Know ...

In the Feature and Operation trees, instead of right clicking items and selecting *Edit Definition* on the context menu, you can double-click the item to open the corresponding dialog box for editing the Stock Manager, Machine, Setups, Features and Operations.

2. Milling is the default machining type that is set when SOLIDWORKS CAM is first installed. The default machining type is specified in the Technology Database. This is the machine used for all the tutorials for Turn machining in this manual. When you use SOLIDWORKS CAM to machine your own parts, select the machine tool you want to use.

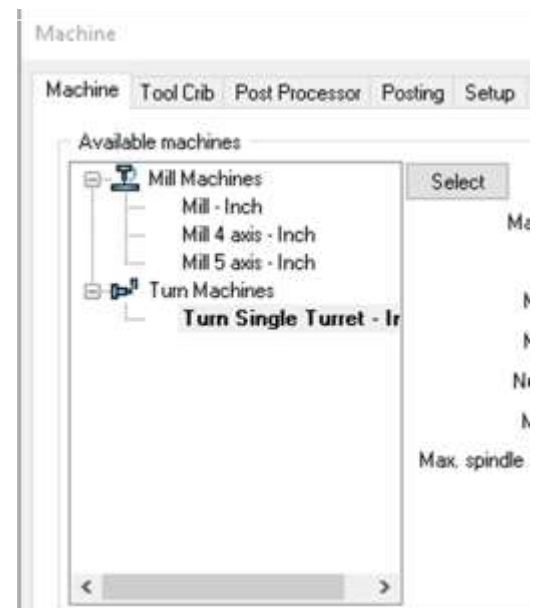

Selecting the Machine

Machines and the Machine tools are set up in the TechDB. Before using SOLIDWORKS CAM to machine your parts, make sure you define the machine and the machine tools available in your facility within the TechDB.

In this tutorial, the tutorial turn part will be machined using a Turn Single Turret machine defined in the TechDB.



For details on customizing the TechDB to suit your facility's requirements, refer the manual 'Technology Database Tutorial'.

In the *Machine* tab of this dialog box, highlight *Turn Single Turret- inch* in the list of *Available machines* and click the *Select* button. (The list of *Available machines* displays all machines defined in the TechDB.) Executing this command replaces the currently active Mill machine with the [*Turn Single Turret-inch*] machine. The selected Turn

machine will be listed in SOLIDWORKS CAM Feature Tree when you close the Machine dialog box by clicking the *OK* button.

3. Click on the *Tool Crib* tab.
  - a. Make sure the *Tool crib priority* option is unchecked.
  - b. In the *Available tool cribs* list at the bottom of this tab, highlight *Tool Crib 2 Rear (Inch)* and click the *Select* button. This action switches the active tool crib for the part to the tool crib named *Tool Crib 2 Rear (Inch)*.

The name of the selected tool crib will be displayed below the *Select* button.

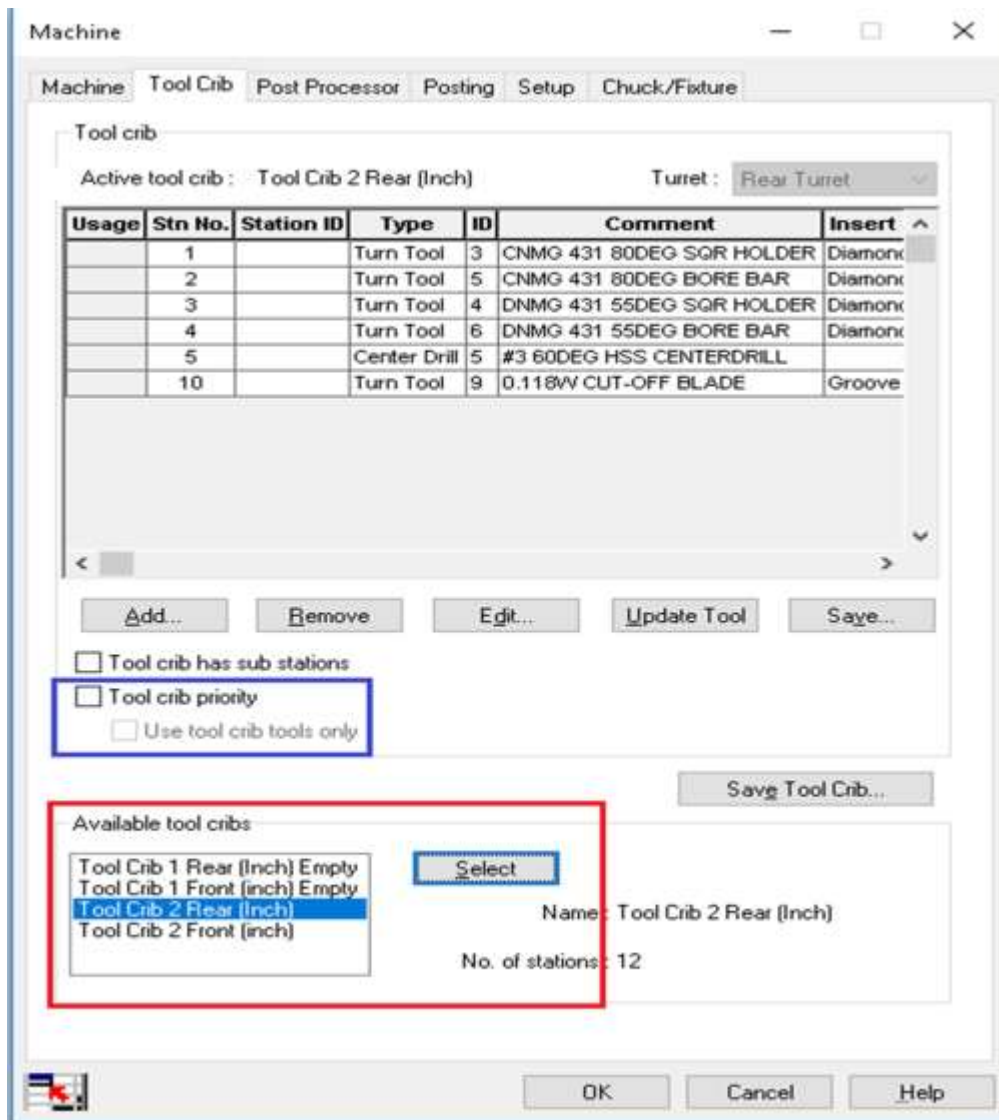

### Selecting Tool Crib

The *Tool Crib* page allows you to choose the tool crib (set of tools) that is used with the machine you have chosen. These are not all the tools that are available but a subset that you can modify to represent the actual set of tools that the machine has loaded.

*Tool Crib 2 Rear (Inch)* is not the default tool crib that has been set up for the sample turn machine. As this tutorial makes use of this tool crib, you have to switch the tool crib to make it the active tool crib. When you define your machine tools in the Technology Database, you can set up your own tool cribs.

4. Click the *Post Processor* tab.

Highlight *T2AXIS-TUTORIAL* (the tutorial post processor) in the list and click the *Select* button. This action assigns *T2AXIS-TUTORIAL* as the Active post processor.

If the post processors do not display, use the *Browse* button to locate the folder containing the files (\*.ctl). By default, tutorial post processors are located in the following folder. *Drive:\Program Data\SOLIDWORKSCAMData\Posts*

Information displays about *T2AXIS-TUTORIAL*. A short description displays in the window. This window contains information only if an optional file has been created for the post processor.

*T2AXIS-TUTORIAL* is the post processor used for the Turn machining related tutorials in this manual. When you use SOLIDWORKS CAM to machine your own parts, select your post processor.



**Contact your SOLIDWORKS CAM reseller for more information on obtaining and/or customizing post processors for your machine tool.**

5. Click the *More* button.

A longer description displays. The *More* button is activated only if a second optional file has been created. This information is intended for use in training or as a detailed description of post processor attributes that can be created.



**Information files are provided for the sample post processor. Your SOLIDWORKS CAM reseller or your company manager may be able to supply these files if they are available for your post processor. If files are not available, you can create post information files as explained in the context-based Help.**

6. Click the *Posting* tab.

The parameters in this tab provide information required to generate the NC program. The parameters are machine-dependent and different parameters may display for the selected post processor. The value for a parameter is output in the NC code if the machine requires it.



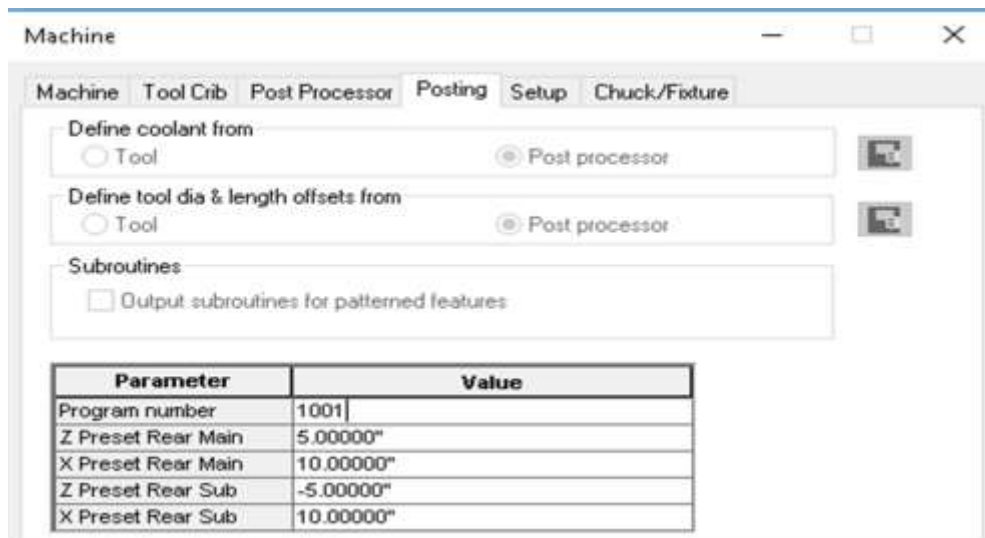

**Posting tab: Displays information and parameter values related to generating NC code**

If you have installed the Feed/Speed Library, you can specify a material on this tab or when you define the Stock. If the Feed/Speed Library is not installed, you can specify the material only on this tab.

The *Z Preset* and *X Preset* values are used by the system for a return position. These values are absolute numbers from X0, Z0. If your machine requires an absolute preset to be output in the program, these values are used. If you always change tools at the same position, setting these values saves you time later.

The *Maximum RPM* defines the maximum RPM that your machine allows when running Constant Surface Feed per Minute (CSFM). This prevents an over-speed spindle alarm as the tool moves to centerline. If necessary, you can set a lower maximum RPM for individual operations.

- Type **1001** for the *Program Number*.

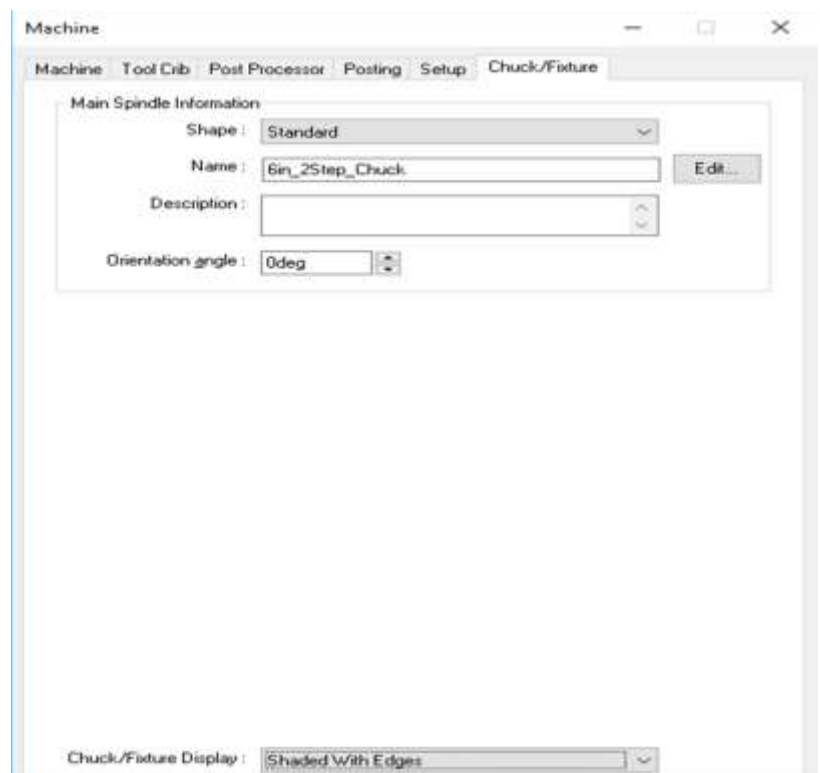

**Chuck/Fixture related information of the Main Spindle**

8. Click on the *Chuck/Fixture* tab.

The Chuck tab allows you to define the Chuck geometry (size of the chuck base and the jaws) during toolpath simulation.

The chuck base and jaws can be viewed in the Graphics area of SOLIDWORKS when the *Chuck* Tab is selected within the *Machine* dialog box.

The *Main Spindle Information* group box displays information related to the Main Spindle.

In this tutorial, the turn part will be machined using only the Main Spindle.

9. Click *OK* to close the *Machine* dialog box.
10. Switch to SOLIDWORKS CAM Operation tree. Right-click on the *Machine [Turn Single Turret -inch]* node in this tree and select ***Chuck/Fixture Display>> Transparent*** from the context menu. Observe that the chuck/Fixture is displayed on the part in the SOLIDWORKS Graphics area.
11. Switch to SOLIDWORKS CAM Feature tree.

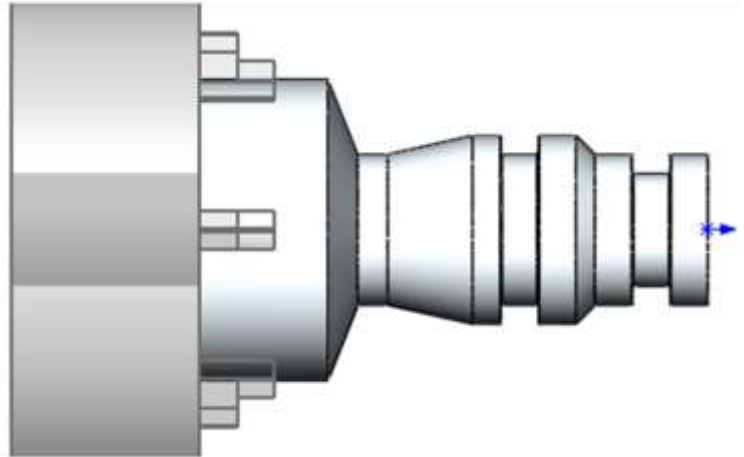

**Chuck/Fixture displayed on the part in the graphics area**



**To control the chuck display settings, right click on the *Machine* item in the SOLIDWORKS CAM Operation tree and choose the appropriate Display state within the Chuck Display cascading menu. The display states for the chuck include *Wireframe*, *Transparent*, *Shaded* and *Shaded with Edges*.**

**If you do not wish to view the chuck in the graphics area, right click on the *Machine* item in the tree and select the *Chuck Display* state as 'None'.**

## Step 4: Edit the Stock Definition

Stock is the material from which the part will be machined. The default Stock is the smallest cylinder (bar stock) that the part will fit into. Typically, this is not the size of the stock you will be using. You can change the Stock definition either by offsetting the length and/or diameter of the bar stock from the part or by defining the Stock from a closed sketch (for a casting or forging). Currently, the sketch has to be in the same plane as the Stock in terms of the X and Z plane and must be a closed profile. No revolved line is needed for the geometry.

In this tutorial, you will define the Stock as a cylinder (bar stock) offset from the part in length.

**Following are the steps:**

1. Right click *Stock Manager* item in the Feature tree and select *Edit Definition* on the context menu.



OR

1. Double click *Stock Manager* item in the Feature tree.

OR

1. Click the *Stock Manager* button on the SOLIDWORKS CAM Command Manager.

The *Stock Manager* dialog box is displayed.

2. Select **304L** as the material from the *Material* dropdown list.
3. Leave the Stock type set to *Round Bar Stock*.  
The stock type can be defined from a revolved closed sketch, WIP sketch file or an STL file. Defining the stock using these types will be explored in later tutorials of this manual
4. In the *Bar Stock Parameters* group box, change the  *Stock Length* dimension to **6.85in**.
5. Leave the  *Outside Diameter* set to **4in**.
6.  Click *OK* to close the *Manage Stock* dialog box.

The Stock will be updated in the graphics area.

7. Right click on the *Stock Manager* in the Feature tree and select *Display>>Translucent* in the cascading context menu. The stock will now be displayed in the graphics area whenever you select the *Stock Manager* item in both the *Feature* tree and *Operation* tree.

Notice the Stock line moved out from the face by **0.1in** (in the +Z-axis direction).

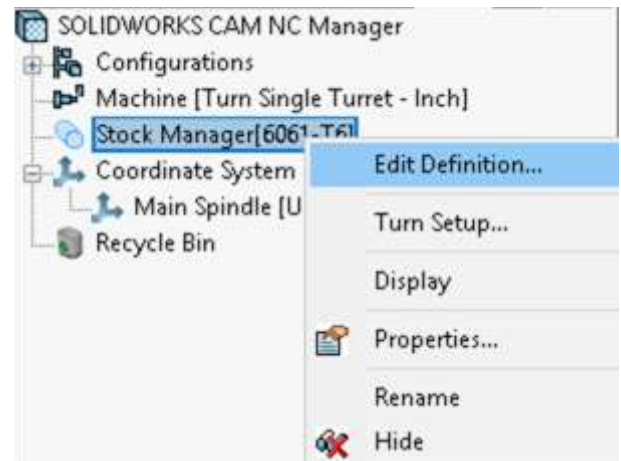

**Command to open the Stock Manager dialog box**



**Stock Manager Dialog Box**

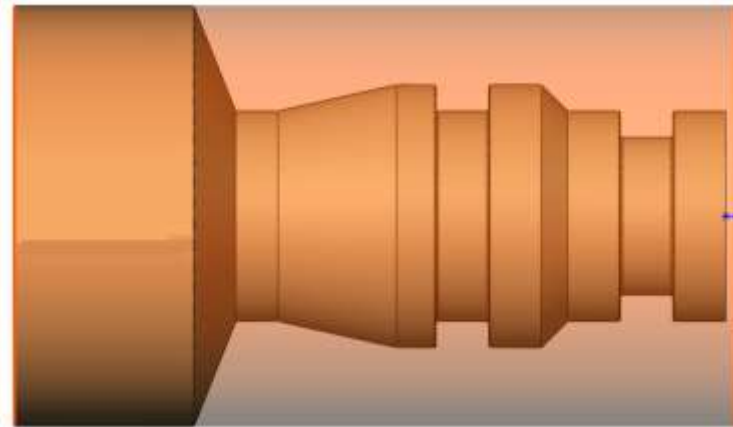

**Stock displayed over the part in translucent shade**

## Step 5: Define Machinable Features

In SOLIDWORKS CAM, machining can be done only on machinable features. You must use either of the following two methods to define machinable features:

- **Automatic Feature Recognition (AFR)**

Automatic Feature Recognition analyzes the part shape and attempts to define most common machinable features such as grooves, outside and inside profile features, and face features. Depending on the complexity of the part, AFR can save considerable time in defining machinable features for turn solid parts.



Use the *Extract Machinable Features* command available on the SOLIDWORKS CAM Command Manager/ SOLIDWORKS CAM menu or the RMB context menu of the *SOLIDWORKS CAM NC Manager* to recognize features by AFR.

- **Interactive Feature Recognition (IFR)**

If AFR does not recognize a feature you want to machine, you can define the feature interactively using the *New Turn Feature* command.

### **Using Automatic Feature Recognition (AFR)**

*Automatic Feature Recognition* is one of SOLIDWORKS CAM's most powerful features. The idea of AFR is to scan the part for features that can be machined. This process is much the same as what you would do if you were to pick up a part that you had to machine. You would look it over, take measurements and begin deciding what machining processes you would need.

SOLIDWORKS CAM does not machine the SOLIDWORKS features directly. Instead, it creates a separate list of Machinable Features. This is because a single SOLIDWORKS feature may have several areas that need to be machined in different ways with different tools.

The part used in this tutorial contains the following machinable features, which are defined automatically by SOLIDWORKS CAM:

- Face Feature
- OD Profile Feature
- Rectangular Groove Features
- Cutoff Feature

## Defining Machinable Features Automatically

### Automatic Feature Recognition

 Click the *Extract Machinable Features* button on the SOLIDWORKS CAM Command Manager.

OR

Right click *SOLIDWORKS CAM NC Manager* in the Feature tree and select *Extract Machinable Features* on the context menu.

The Message Window is displayed. This window displays automatically to report the progress of the current process. Generating Setups is always the last item during Automatic Feature Recognition. When you see the line 'Generating Setups' in the message window, you can be sure that the process is almost complete.

You can control whether the Message window displays temporarily or permanently. 

Click on the SOLIDWORKS CAM *Options* button on the SOLIDWORKS CAM Command Manager. This action opens the Option dialog box. On the General tab of this dialog box, check the *Message Window* option.

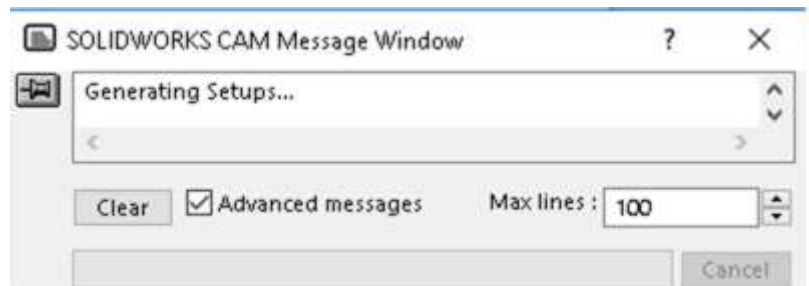

**SOLIDWORKS CAM Message Window**

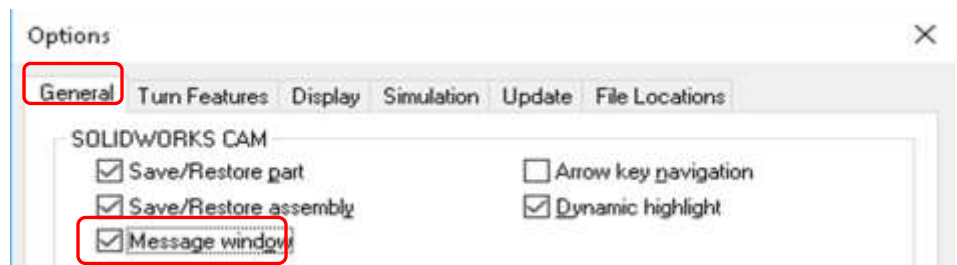

**SOLIDWORKS CAM Options Dialog box - General Tab**



To view the Options dialog box, you can also click **SOLIDWORKS CAM** on the menu bar OR right click **SOLIDWORKS CAM NC Manager** in the Feature tree and select the **Options** command.

On execution of the *Extract Machinable Features* command, SOLIDWORKS CAM generates the Turn Setup and the machinable features. The items are displayed in the Feature tree.

**Turn Setup:** The Turn Setup is the 2 axis (X and Z) plane that the tool movement will be based on. It has an origin location, and X, Y, and Z direction vectors. The Turn Setup is created automatically; however, you can move the origin and change the direction and angles of the axis. Most turning applications work in the X and Z plane, which is relative to the SOLIDWORKS Y and X axis plane respectively. When you define the Stock as bar stock, only one Turn Setup (X and Z) is created and all features will be machined using tool orientations that are relevant for a rear turret machine configuration.

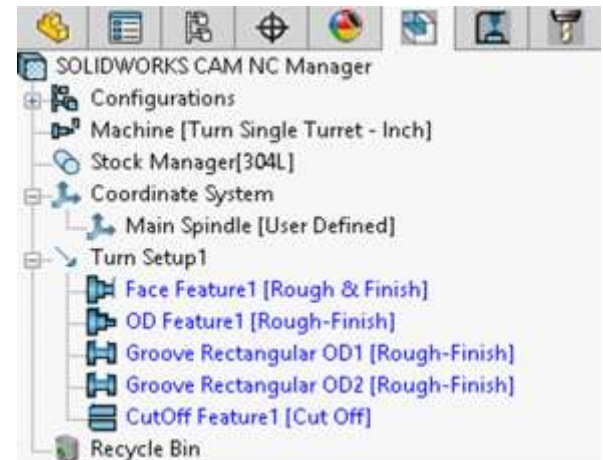

**Features recognized by AFR listed in Feature tree**

**Feature Tree:** The Feature tree allows you to:

- Copy, rename, suppress, delete and combine machinable features
- Change machinable feature parameters
- Change the order in which the features are machined
- Insert Turn features
- Search for a feature based on item name
- Hide or show feature display in graphics area
- Generate an Operation Plan and find the first operation for a feature



### **Did You Know ...**

When you recognize features by Automatic Feature Recognition (AFR) or Interactive Feature Recognition (IFR), the features listed in the Feature tree will display in different color **Blue color** (by default) till you generate operations for these features. Once a valid operation is generated, the color of the corresponding feature item will change **Black color** (by default) indicating successful generation of the operation(s). If operations could not be generated for a feature (because the feature conditions have not been defined in the Technology Database for that particular feature type), then the feature will continue to display in the initial color (**Blue color**), thus indicating that they have no operations defined.

You can set these colors on the **Display** tab in the Options dialog box.

## Changing Feature Parameters

Most feature parameters are fixed; however, some parameters can be changed using the *Parameters* command on the context menu for the feature item in the Feature tree.

1. Right click *OD Feature1* in the Feature tree and select *Parameters* from the context menu.

The *OD Profile parameters* dialog box is displayed. Since there is no physical information about the type of profile, SOLIDWORKS CAM allows you to define a *Strategy* for the profile.

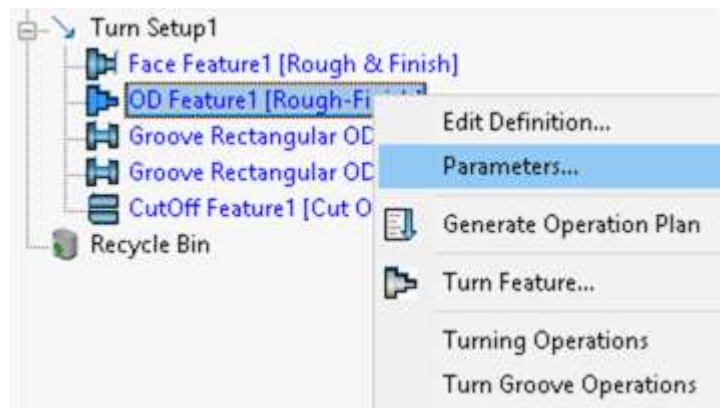

Select Parameters from the RMB context menu

2. Click the down arrow next to *Rough-Finish* in order to view the *Strategy* dropdown list containing the choices.

*Rough-Finish* and *Thread* are system Strategies.

User-defined Strategies are also listed, if defined. For example, RF80-80 is a shortcut name for roughing and finishing the profile using 2 tools (80 degree diamond tools).

3. Leave the Strategy set to *Rough-Finish* and click *OK* or *Cancel* to close the dialog box.

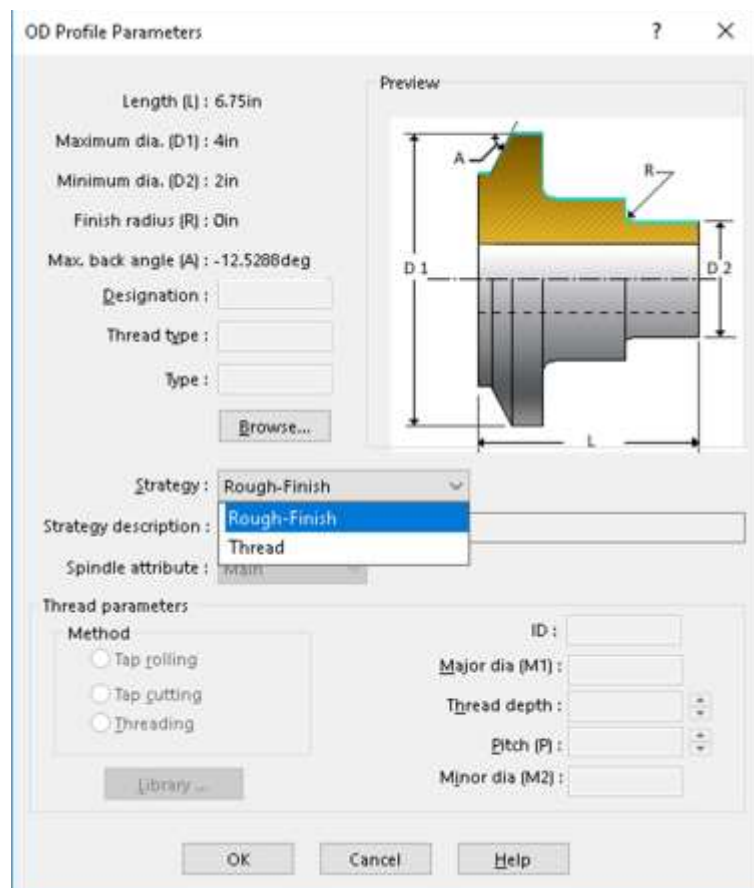

Feature Parameters Dialog Box

## Save the part with the machinable feature data

1.  Click the *Options* button the SOLIDWORKS CAM Command Manager to open the options dialog box.
2. Make sure the *Save/Restore part* option on the *General* tab is checked, then click *OK* to close the dialog box.

- If this option is checked, when you save and close a part document, the machining data is saved.

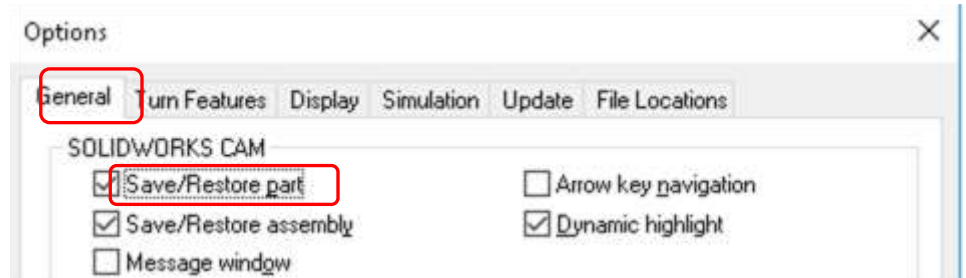

**SOLIDWORKS CAM Options Dialog box - General Tab**

- When the part document is opened again, the machining data is restored along with the part design information.
  - If this option is not checked, when you save and close a part document that contains at least one SOLIDWORKS CAM Setup, a message indicates that *Save/Restore* is disabled. If you click *Yes*, SOLIDWORKS CAM saves all SOLIDWORKS CAM data before closing the file. If you click *No*, SOLIDWORKS CAM closes the part and discards any new SOLIDWORKS CAM data since the last save.
3. Click on the *File* menu and select *Save As* on the dropdown menu.
  4. In the *Save As* dialog box, type in the desired file name and click the *Save* button.



**Make sure you save frequently. When you open a file, you are actually working on a copy of the file. The original is still stored on disk. Periodically saving your file ensures that your latest work is retained.**

## Defining Features Interactively (IFR)

Automatic Feature Recognition can save a significant amount of time; however, AFR does have its limitations. AFR cannot recognize every feature on complex parts and does not recognize some features such as certain types of grooves. To machine these areas, you need to define machinable features interactively using the *New Turn Feature* command.

SOLIDWORKS CAM also provides the flexibility to edit machinable features to accommodate machining requirements. For example, if you want the OD machined in segments to take into account possible machining rigidity, you can define features for the segments in the OD Feature as shown in this tutorial as well as subsequent tutorials in this chapter.

In this tutorial, you will insert an OD Feature so that you can rough turn the first OD step of the part. This OD segment will be finished in the Turn Finish operation for *OD Feature1*.



Steps to interactively insert OD feature:

1. Right click *OD Feature1* in the Feature tree and select *Turn Feature* on the context menu.  
The *New Turn Feature* dialog box is displayed.  
The part profile is shown in the graphics area.  
Rotate the part to view the part profile in case it is not visible.
2. In the *Features* group box this dialog box, select *OD Feature* for Type.
3. Leave the *Strategy* set to *Rough-Finish*.
4. In this tutorial, we will interactively define a feature picking the segment(s) on the highlighted geometry of the part. Hence, in the *Define from* group box, leave the method set to *<Part Profile>*.
5. Since the part does not contain any non-revolved features, leave the *Part Profile Method* set to *Plane Section*.
6. In the graphics area, the profile of *OD Feature1* is highlighted on the part. Pick the first OD profile segment (face) to the right of the groove closest to the face to select it. The single segment is highlighted.

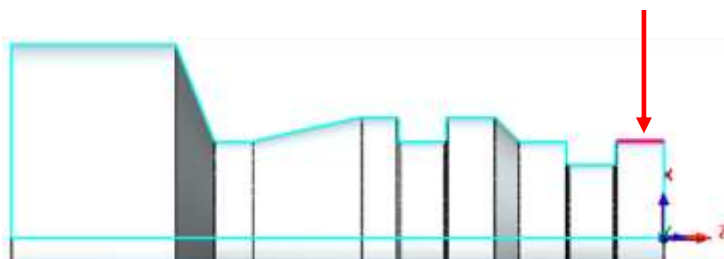

**Pick the first OD profile Segment**

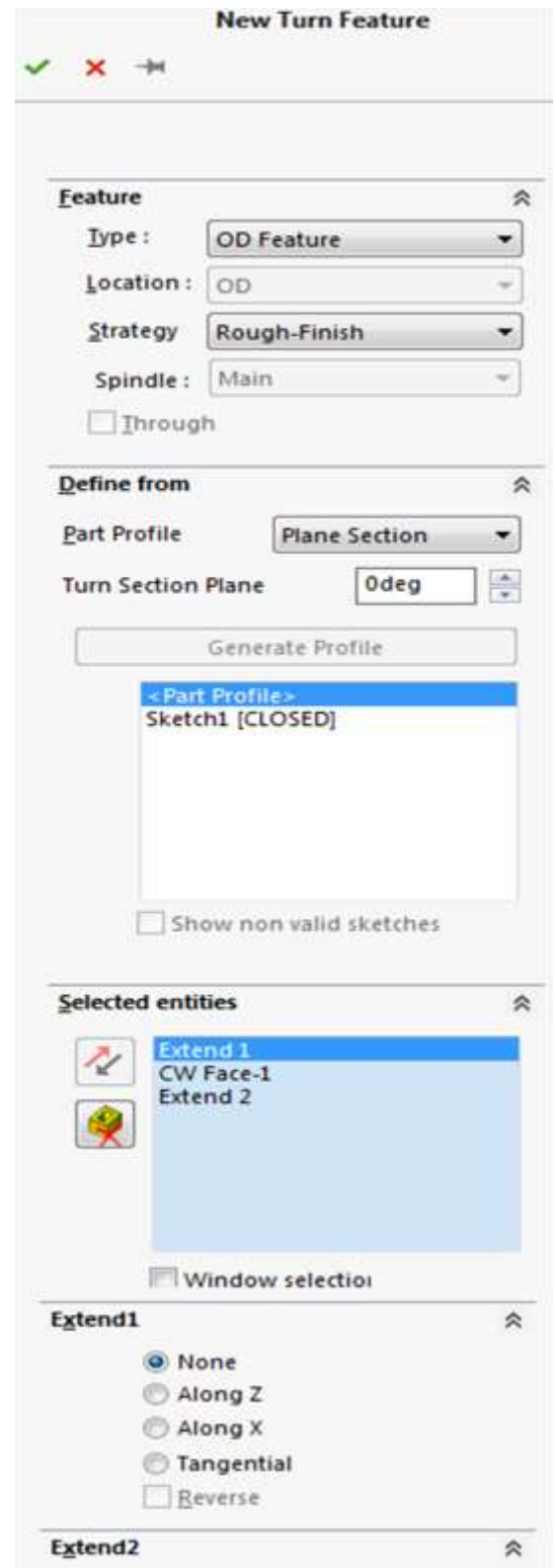

**New Turn Feature Dialog Box**

The selected segment (face) will be listed in the *Selected entities* list box of the dialog box as *CW Face-2. Extend 1* and *Extend 2*, which are parameters used to determine how the toolpath is computed at the ends of the feature, are listed in this box.

7. In the *Extend 2* group box, set the Extend to *Along X*.

This terminates the feature at the end of the segment and up to the Stock major OD.

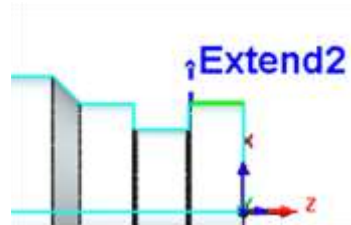

**Defining Extend 2**

8.  Click *OK* to apply the changes. *OD Feature2* displays in the SOLIDWORKS CAM Feature tree. You have now defined all the machinable features in this part.

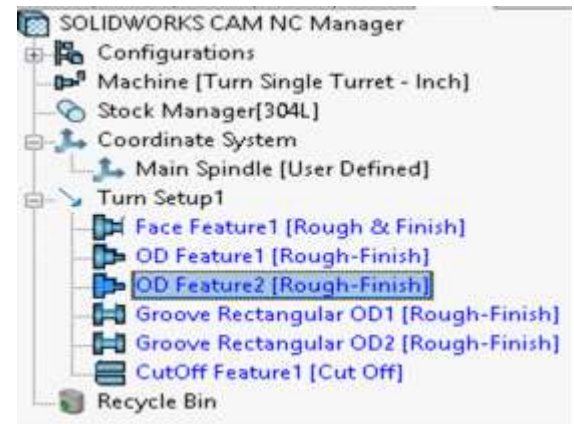

**OD Feature 2 inserted interactively**

### Reordering the features in the Feature tree

In the SOLIDWORKS CAM Feature tree, drag *OD Feature2* above *OD Feature1* in the tree using the mouse.

You need to reorder these features because you want to rough *OD Feature2* before cutting the entire OD. If you generated operations and toolpaths without reordering, SOLIDWORKS CAM would generate toolpaths for *OD Feature1* first, which includes the segment in *OD Feature2*. Toolpaths would not be generated for *OD Feature2* since there would be no material left to remove.



Before Reordering



After Reordering

## Step 6: Generate Operation Plan and Adjust Operation Parameters

An Operation Plan contains information on how each machinable feature is to be machined and how the NC code will be output. When *Generate Operation Plan* command is run, operations for each machinable feature are created automatically based on information in the TechDB.



### Did You Know ...

In some situations, the operations defined for a feature in the TechDB may not be sufficient and additional operations may be required. You can insert operations interactively using the *New Turn Operation* command. This command is explained in detail in the **SOLIDWORKS CAM context-based Help**.

1.  Click the *Generate Operation Plan* button on the SOLIDWORKS CAM Command Manager.

OR

Right click *Turn Setup1* in the Feature tree and click *Generate Operation Plan* on the context menu.

SOLIDWORKS CAM generates the operation plan for all the machinable features in *Turn Setup1*.

The Operation tree is displayed and it lists the operations that were generated. The listed operations are displayed in **blue** color (default color setting). This color indicates that toolpaths have not yet been generated for the operations.

2. Click on the SOLIDWORKS CAM *Feature tree* tab. Observe that the font color of all the listed features has changed from **blue** to **black** (default color settings). This change in color for all the features indicates that operations were generated for all the features.

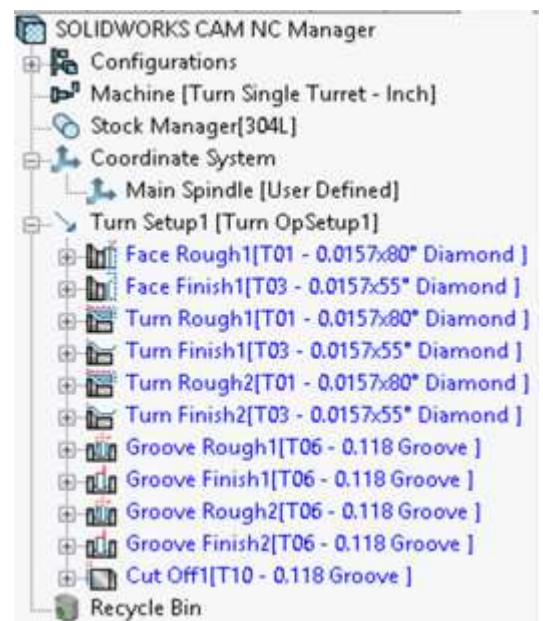

Generated Operations listed in Operation Tree



You can set the color for the features listed in the Feature tree on the *Display* tab of the *Options* dialog box.

3.  Click the SOLIDWORKS CAM *Operation Tree* tab to display the Operation tree again.



**Operation Tree tab**

**Operation tree:** The Operation tree provides an outline view of the operations for the machinable features. Operations are listed under the Turn Setup in the same order as the machinable features. At the top of the tree is the NC Manager. The Stock Manager and Machine items are the same as in the Feature tree. You can change the definition of your stock and the post processor used by SOLIDWORKS CAM to produce G-Code.

The Operation tree allows you to:

- Insert, rename, suppress and delete operations
  - Change operation parameters
  - Edit the feature list
  - Change the machining order
  - Generate toolpaths
  - Simulate toolpaths
  - Hide or show toolpath display
  - Post process the toolpaths
  - Search based on an item name
4. Click the plus sign (+) next to *Turn Finish1*.

This action displays the name of the machinable feature that this operation is going to machine.

5. Right click *Turn Finish1*, select *Delete* on the context menu and click *Yes* to confirm the deletion.



**Expand the Operation item to view the feature it machines**

- Based on the information in the TechDB, rough and finish operations were generated for *OD Feature2*. In this tutorial, you want to finish turn this OD segment in the finish operation for the entire OD (*Turn Finish2*) so you can delete the finish operation.

- If you typically machine the OD in segments, you can customize the TechDB and set up a Strategy to generate only a rough turn operation for this type of OD feature.

The operations that are generated by SOLIDWORKS CAM are based on information stored in the Technology Database. Each operation contains parameters that affect how the toolpath is created and specific parameters that will be output to the NC program. These parameters can be edited before generating the toolpaths and post processing the part.

6. Double click *Turn Rough1* (Roughing operation for *OD Feature2*) in the tree. The *Operation Parameters* dialog box for the operation is displayed.

The *Operation Parameters* dialog box gives you access to all the parameters used to define the toolpath. This dialog box also provides access to the parameters for the tool you are using and allows you to select a different tool.

7. Click on the *Turn Rough* tab. In the *Profile Parameters* group box, change the *First cut amount* to **0.15in**.
8. Click on the other tabs and view the parameters. When you cut your own parts, you can edit these values as per your machining requirements.
9. Click *OK* to apply the changes made and close the dialog box.

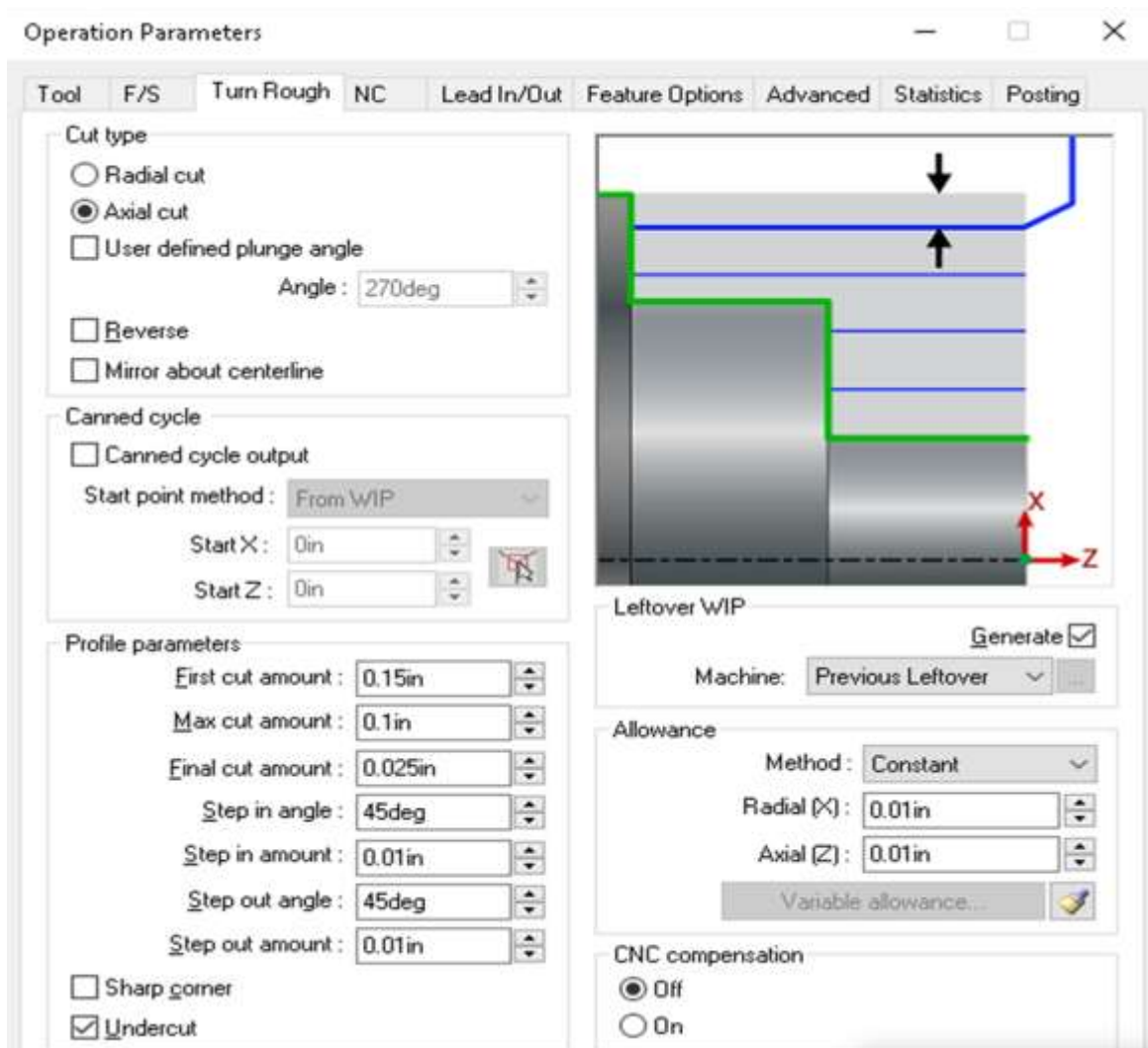

**The Operation Parameters Dialog Box**

## Step 7: Generate Toolpaths

SOLIDWORKS CAM calculates toolpaths using the operation parameters to define how to machine each machinable feature.

1.  Click the *Generate Toolpath* button on the SOLIDWORKS CAM Command Manager.

OR

Right click *Turn Setup1* in the Operation tree and select *Generate Toolpath* on the context menu.

On executing the *Generate Toolpath* command, SOLIDWORKS CAM calculates the toolpaths for each operation in the Setup. The font color of all the listed operations in the Operation tree changes from **blue** to **black**. This change in color indicates that toolpaths were successfully generated.

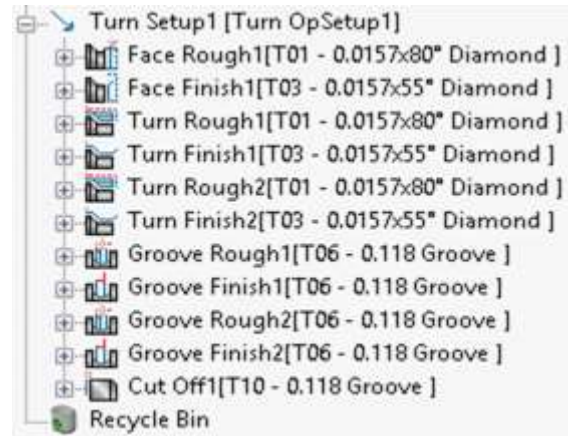

**Black font color of the operations indicates that toolpaths were successfully generated**



### Did You Know ...

If an operation displays in **blue** color instead of **black**, then it indicates that toolpaths have not been generated. This might occur in one of the following situations:

- i. When you insert a new operation interactively;
  - ii. When you insert a new feature interactively and then generate operations for the new feature;
  - iii. When SOLIDWORKS CAM cannot generate the toolpath for an operation because of an error in the toolpath algorithm or a parameter is not correct.
2. Left click any operation in the Operation tree. That operation will be highlighted in the Operation tree.
    - The toolpath for that highlighted operation will be displayed in the graphics area. As you highlight each operation in the tree, the toolpaths for that corresponding operation will be displayed.
    - Turning operation parameters can be edited and the operation can be renamed, moved, suppressed, deleted, etc. after toolpaths have been generated. These commands are available in the RMB context menu.
    - If you make any changes, the toolpaths must be updated by selecting Generate Toolpath again at the Setup level.
  3. Hold down the *Shift* key and select the first and last operation in the tree. This action selects all the operations.

The toolpaths for all the operations will be displayed on the part showing the centerline of the toolpath.

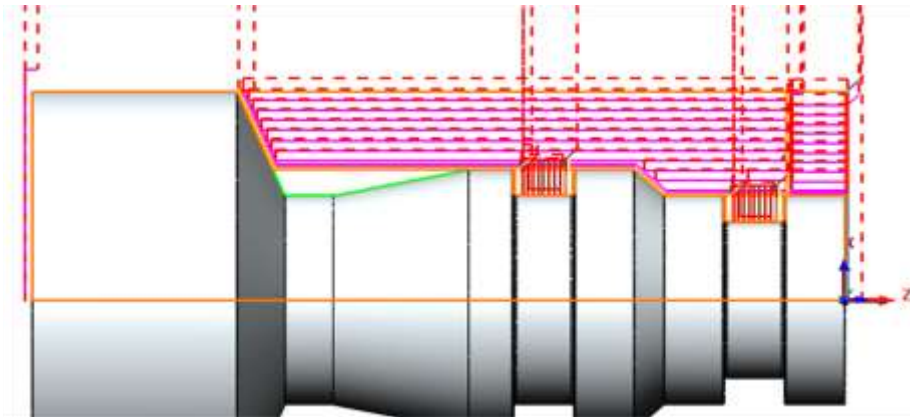

**Toolpaths for all the operations displayed on the part when all the operations are selected in the operation tree**

## Step 8: Simulate Toolpaths

SOLIDWORKS CAM provides the ability to simulate the toolpaths showing the tool movement and the resulting shape of the part.

1.  Click the *Simulate Toolpath* button on the SOLIDWORKS CAM Command Manager.

OR

Right click on *Turn Setup1* in the operation tree and select *Simulate Toolpath* on the context menu.

On executing this command, the *Toolpath Simulation* toolbar is displayed.

Some of the options you can select to customize the simulation include:

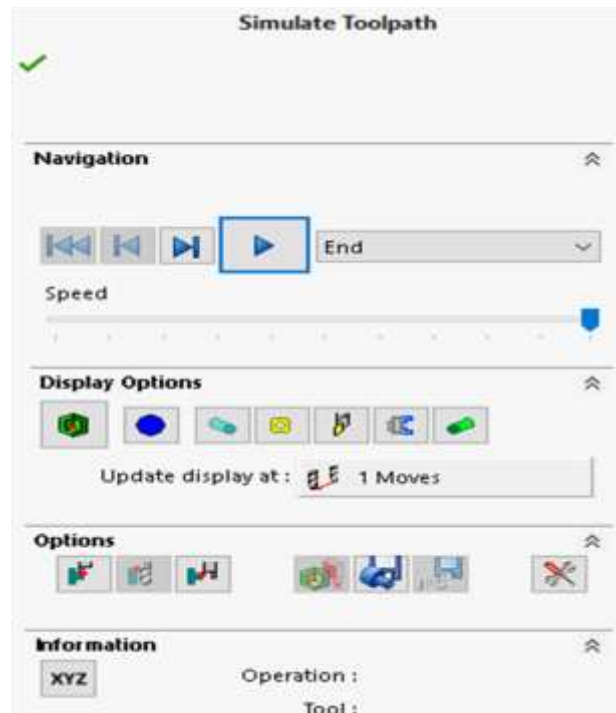

### Toolpath Simulation toolbar

Update the Stock after each cut or show the completed part at the end of the simulation.

- Change the display of the stock, tool, tool holder, and target part (wireframe, translucent, shaded, or no display).
- Run the simulation to the end or advance by single step or by feature.
- Compare the design part and the simulated part during simulation.
- Show a cross section of the material removal.
- Show holder and fixture collisions.
- Control the simulation speed by dragging the Simulation Speed Control slider.



If you want to simulate only the toolpath for a given operation, you can right click that operation and then select *Simulate Toolpath* from the context menu.



2. When you click on the display control buttons of the Toolpath Simulation toolbar, the available settings associated with that button are displayed in a dropdown list.

3. Set these toolbar buttons as below:

- Show Difference
- Section View: *Full*
- Stock: *Shaded with Edges*
- Tool: *Shaded with Edges*
- Tool Holder: *Shaded with Edges*
- Fixture: *No display*
- Target Part: *Shaded with Edges*
- Tool Collision: *Tool Ignore Collision*
- Tool Holder Collision: *Tool Holder Ignore Collision*

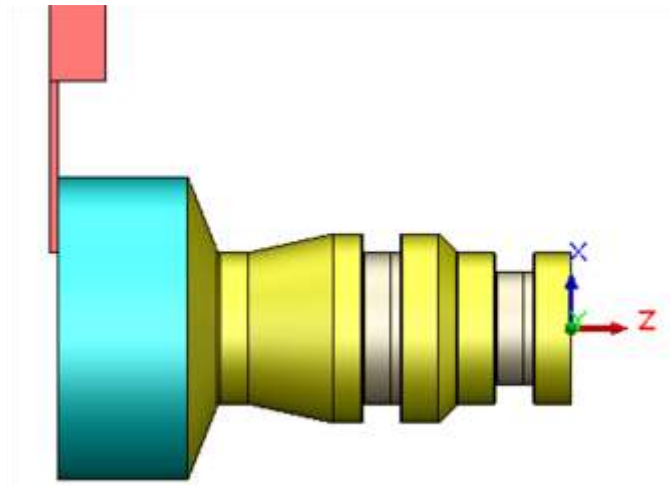

**Toolpath Simulation**

4. In the *End Condition* dropdown list, select *Next Operation*.

5. Click the *Run* button.

The simulation is run with the tool displayed during simulation. As the End Condition is set to Next Operation, only the first operation is simulated. Click the *Run* button each time you wish to simulate the subsequent toolpaths. The toolpaths will be simulated in the serial order of the operations listed in the Operation tree.

6. Use the *Simulation Speed Control* slider to control the speed of the Simulation.

7. To pause the simulation while it is running, click on the *Pause* button. When you click *Run* button again, the simulation will continue from the point where it was paused.
8. Click the *Close* button in the upper right corner of the Toolpath Simulation toolbar to exit the simulation mode and return to the SOLIDWORKS/SOLIDWORKS CAM Solids display.



**Did You Know ...**

**SOLIDWORKS CAM provides an option to display the XZ position of the tool in the Message Window during simulation. To activate this option, select the Options command on the SOLIDWORKS CAM Command Manager to open the Options dialog box. On the General tab, ensure that the Message Window option is checked. On the Simulation tab, select the Display Coordinates option.**

## Change the Machining Order



Operations are generated in the same order that the machinable features are listed in the tree. This may not cut the part in the order you think is most efficient or practical for your machining requirements. You can drag and drop operations in the tree to reorder them.

For example, it is more practical to first machine the groove closest to the face rather than any other groove. Similarly, it is prudent to first rough machine the grooves followed by the Finish operations.

1. Drag and drop the *Groove* operations in the order shown in the tree on the right.

2.  Click the *Generate Toolpath* button on the SOLIDWORKS CAM Command Manager.

If you change the order of the operations after you generate toolpaths, you must regenerate the toolpaths so that the work in process can be updated.

3.  Simulate the toolpaths.  Run the simulation and observe that the groove closest to the face is cut first and both grooves are rough cut and then finished.

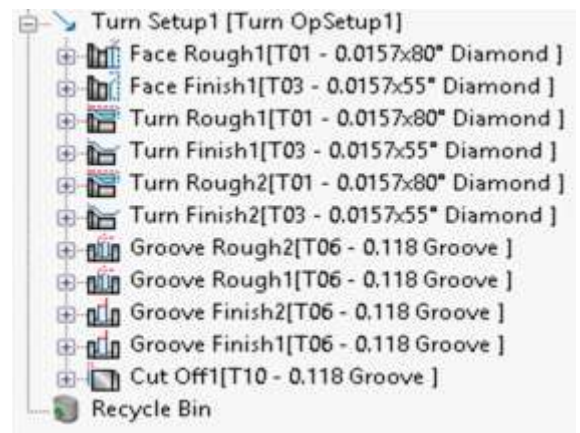

**Operation Tree after reordering Groove operations**

## Step 9: Post Process Toolpaths

Post processing is the final step in generating the NC program file. This step translates generalized toolpath and operation information into NC code for a specific machine tool controller. SOLIDWORKS CAM creates NC code for each toolpath in the order the toolpath operation appears in the Operation tree. When you post process a part, SOLIDWORKS CAM creates two files: the NC program and the Setup Sheet. These are text files that you can read, edit and print using a word processor or text editor.

In this exercise, you post process all the operations and generate the NC program:

-  Click the *Post Process* button on the SOLIDWORKS CAM Command Manager.  
OR

Right click the *SOLIDWORKS CAM NC Manager* in the Operation tree and select *Post Process* on the context menu.

The *Post Output File* dialog box will be displayed. Use this dialog box to name and save the NC program file.



**If you are running SOLIDWORKS CAM in Demo mode, the Post Output File dialog box does not display because you cannot save NC code in Demo mode.**

Typically, the NC program and Setup Sheet files are stored in the folder that contained the last part that was opened. If you want these files in another location, you can change the folder location.

If Post Process button is grayed out on the SOLIDWORKS CAM menu, Command Manager [make sure that you have selected a post processor](#) and generated the toolpaths.

1. Click the down arrow to the right of the *Save as type* box.

SOLIDWORKS CAM provides a list of commonly used extensions that you can select. For this tutorial, use the default *.txt* extension.



**Did You Know ...**

If you want change the default extension from *.txt* to one of the ones in the list or if you want a different file name extension for NC program files, you can edit or create a *.pinf* file and specify the new extension. For more information on making these changes, see the context-based Help.

2. If *TURN2AX\_1* is not in the *File name* text box, type ***TURN2AX\_1***, then click *Save*.

You do not have to type the extension if you are using the default *.txt*. Naming the post output file the same as the part file is the most common way of saving parts and NC programs. Both files can have the same name because they have different extensions.

After executing *Save* command, the *Post Process Output* dialog box is displayed. Click the *Step* button  at the top of the Post Process Output dialog box.

SOLIDWORKS CAM starts to generate the NC program and the first line of NC code displays in the NC code output view box. When you click the Step button, SOLIDWORKS CAM generates one line of code.

 Click the *Step* button again. The next line of NC code is displayed.

 Click the *Run* button. Post processing continues until it is completed.

When the post processing is finished, you can view the code using the vertical scroll bar.

3. Click *OK* to close the dialog box.

## Setup Sheets

The Setup Sheet is a printable file that contains information the machine tool operator can use to set up the part and the tools required to produce a part. The information includes the machine, the controller, estimated machine time, the part material, and the tooling used to machine the part.

SOLIDWORKS CAM provides two methods for creating Setup Sheets:

- During post processing, SOLIDWORKS CAM automatically creates a simple text file with a *.set* extension.
- Click *Setup Sheet* command on the SOLIDWORKS CAM NC Manager context menu and the *Generate Setup Sheets* command on the Setup context menu provide a format option:

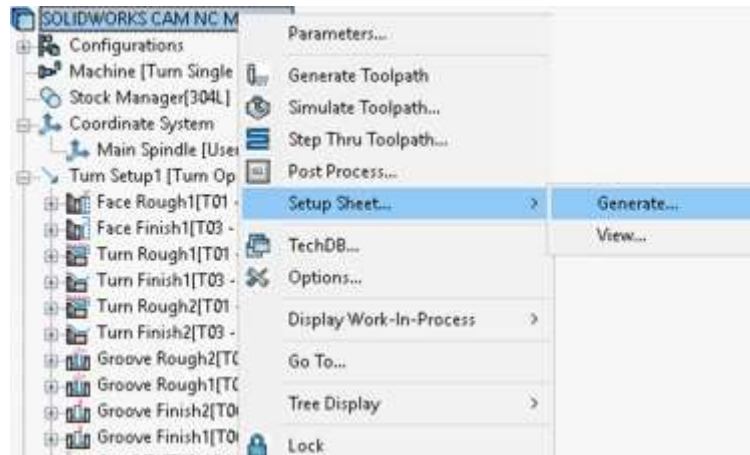

**Setup Sheet Command on SOLIDWORKS CAM NC Manager context menu**

**XML:** In the Setup Sheet Options dialog box, the information is saved in an XML file, which allows the Setup Sheet to be formatted with an HTML style sheet and displayed in a web browser.



Refer the manual 'SOLIDWORKS CAM Setup Sheet Tutorial' for detailed Help on how to generate Setup Sheets.

---

## Turn 2

### Topics covered in this tutorial:

- [Turn feature types recognized by AFR and IFR](#)
- [Editing a tool in the active tool crib](#)
- [Removing a tool from the active tool crib](#)
- [Adding a tool to the active tool crib](#)
- [Saving the changes made to the tools in the tool crib](#)
- [Changing the Feature Strategy](#)

### Turn Feature Types Recognized by AFR and IFR

SOLIDWORKS CAM is a feature-based machining system. Feature-based machining provides numerous benefits because the definition of the feature enables a higher level of automation when creating machining operations and associated toolpaths.

SOLIDWORKS CAM provides two methods for extracting features:

- i. An automatic method called Automatic Feature Recognition (AFR),
- ii. An interactive method using the *New Turn Feature* function.

A SOLIDWORKS CAM file can contain features recognized by any one or both of the above methods.

#### **Supported Turn Feature Types**

The following turn feature types are currently recognized:

- **Face Feature:** A Face feature exists on the outermost portion of the part.
- **OD Profile Feature:** An OD profile feature covers the entire outer surface of the part.
- **ID Profile Feature:** An ID profile feature covers the entire inner surface of the part.
- **Groove Feature with vertical walls:** A Groove is a feature that is totally closed and below the surrounding features.
  - Grooves are further broken down into one of two categories: Rectangular and Outbound.
  - Three types of grooves are supported:
    - ✓ OD Groove
    - ✓ ID Groove
    - ✓ Face Groove
- **Cutoff Feature:** A Cutoff feature is generated on the opposite side of the Face feature when the Stock is defined as bar stock. A Cutoff feature is similar to a face and can be converted to a Face feature for two-step turning operations.

This tutorial demonstrates the types of features identified automatically by the *Extract Machinable Features* command.

## Step 1: Open the Part

In this tutorial, you will extract features and generate operations and toolpaths for a turn part that was imported into SOLIDWORKS.

1. Open the part file **TURN2AX\_2.SLDPRT** located in the following folder.

*C:\Users\Public\Public Documents\SOLIDWORKS\SOLIDWORKS 201x\CAM Examples\Tutorial\_Parts\Turn*

2.  Click on *FeatureManager Design Tree*. Notice that the design tree contains no design features. This part was imported into SOLIDWORKS.
3. Examine the part.

You can recognize various sizes and shapes of faces, profiles and grooves.

It would appear that SOLIDWORKS CAM extracts features based on SOLIDWORKS features used to create the part.

As you will see in this tutorial, this is not necessarily so. The part used in this tutorial is an imported part. This tutorial will demonstrate how SOLIDWORKS CAM determines machinable features.

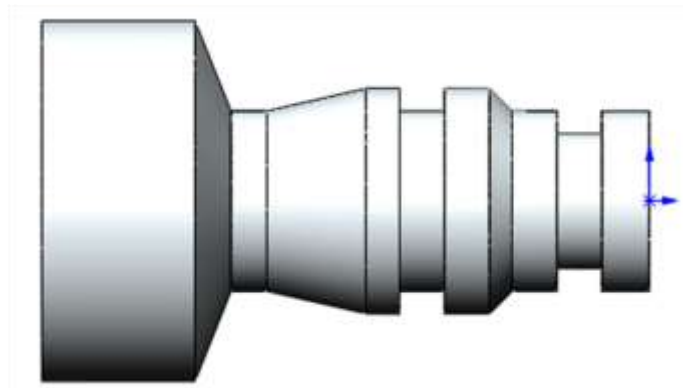



**TURN2AX\_2.SLDPRT**

## Step 2: Defining the Machine and Editing the Stock Definition

### Define the Machine

1. Click the *SOLIDWORKS CAM Feature Tree* tab.
2. Ensure that *Turn Single Turret - inch* is selected as the Machine. If not, then following are the steps:

- i.  or  Double click the *Machine* item in the Feature tree.

OR

- i.  Click on the *Define Machine* button on the SOLIDWORKS CAM Command Manager.



SOLIDWORKS CAM

The *Machine* tab of the *Machine* dialog box is displayed.

- ii. In the *Machine* tab of this dialog box, highlight *Turn Single Turret- inch* in the list of *Available machines* and click the *Select* button.

- iii. Click *OK* button to apply the changes and close the dialog box. Observe that the previously listed Mill machine in the SOLIDWORKS CAM Feature Tree has been replaced with the selected Turn machine.



This machine definition has been created for the SOLIDWORKS CAM exercises. When you use SOLIDWORKS CAM to machine your own parts, select the machine tool you want to use to machine the part.

### Editing the Tool Crib

1. Click the *Tool Crib* tab of the Machine dialog box.  
From this tab, you can add, remove and edit tools in the Tool Crib.
2. Uncheck the *Tool crib priority* option in case this option is checked.
3. In the *Available tool cribs* list, make sure *Tool Crib 2 Rear (Inch)* is the Active tool crib.  
To do so, highlight it in the *Available tool cribs* list and then click the *Select* button.

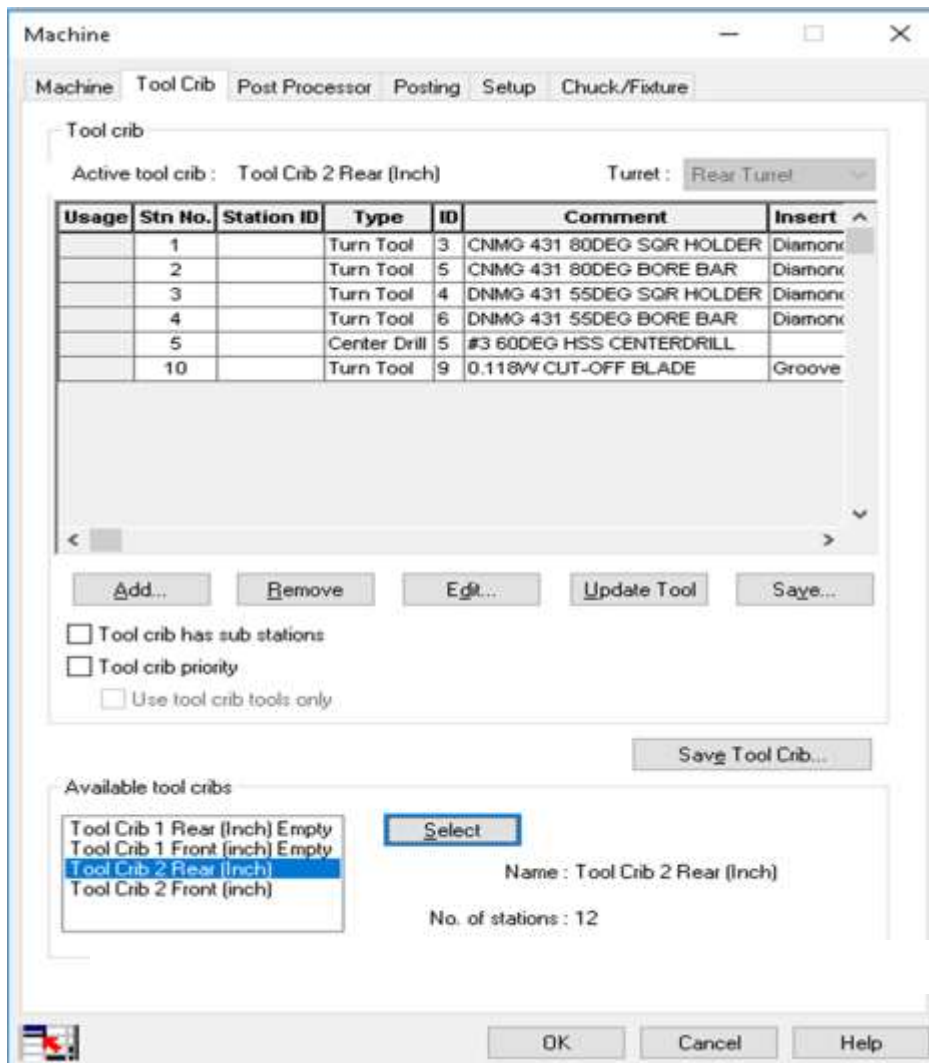

**Tool Crib Tab of Machine dialog box**

## Editing a Tool

1. Select any tool from the Active tool crib list and click the *Edit* button.  
To select a tool in the *Active tool crib* grid, click on any field in the row containing the tool.
2. When you click the *Edit* button for a selected tool, the *Edit Tool Parameters* dialog box is displayed. This dialog box contains three tabs that allow you to change the parameters for the selected tool.
3. Click the tabs to view the tool and holder parameters. If you make any changes to the parameters, click *OK* to apply those changes and close the *Edit Tool Parameters* dialog box. The changes you make in this dialog box affect only the tool crib for the current part.

To change the tool definition for all future jobs, you need to click on the *Save* button in the Tool crib tab else the changes will be applicable only for the current model part. Alternatively, you can edit the Tool Crib definition in the Technology Database.

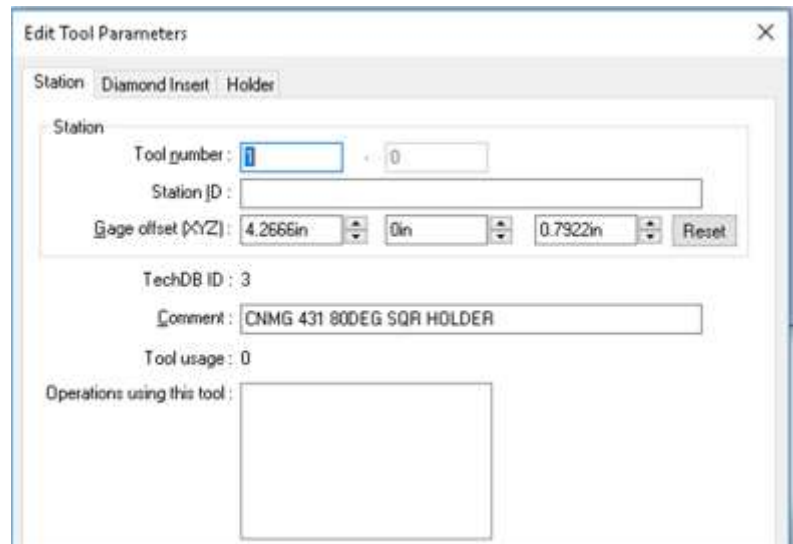

**Edit Tool Parameters dialog box**

## Removing a Tool

To remove a tool from the Active tool crib, select the tool in the Active tool crib grid and then click the *Remove* button.



**The tool removal from the tool crib is effective only for the current part. To make this change available for all future jobs, click on the *Save Tool Crib* button to permanently save the changes.**

## Adding a Tool

Use the *Add* button to add a tool to the Active Tool crib.

1. Click the *Add* button in the Tool Crib tab.
2. The *Tool Select Filter* dialog box is displayed. This dialog box allows you to set filters for displaying and selecting tools. At the bottom of this dialog box is a *Tools database* grid listing all the tools entries from the TechDB which fulfill the tool selection criteria that you select.



In this tutorial, you will insert a Turn tool to the active tool crib.

3. In the *Tool Select Filter* dialog box, select *Turn Tool* from the dropdown list for the *Tool type*.
4. The *Filter by* group box within the *Tool Select Filter* dialog box will now display tool selection parameters for the selected Tool type. The *Tools database* grid too will now display only Turn tools.
5. You can choose to further filter down your tool selection criteria by defining additional filters. For example, in this tutorial, we will select a Turn tool made of material *Carbide*. To do so:
  - a. Check the option *Tool material*. This enables the *Tool material* dropdown list.
  - b. Select *Carbide* from the dropdown list.
  - c. The *Tools database* grid will now display only Turn tools made of material *Carbide*. From this grid, highlight the tool you wish to add to the active Tool Crib.
  - d. You can view the Preview of the highlighted tool in the Preview window.
  - e. Click the *OK* button.

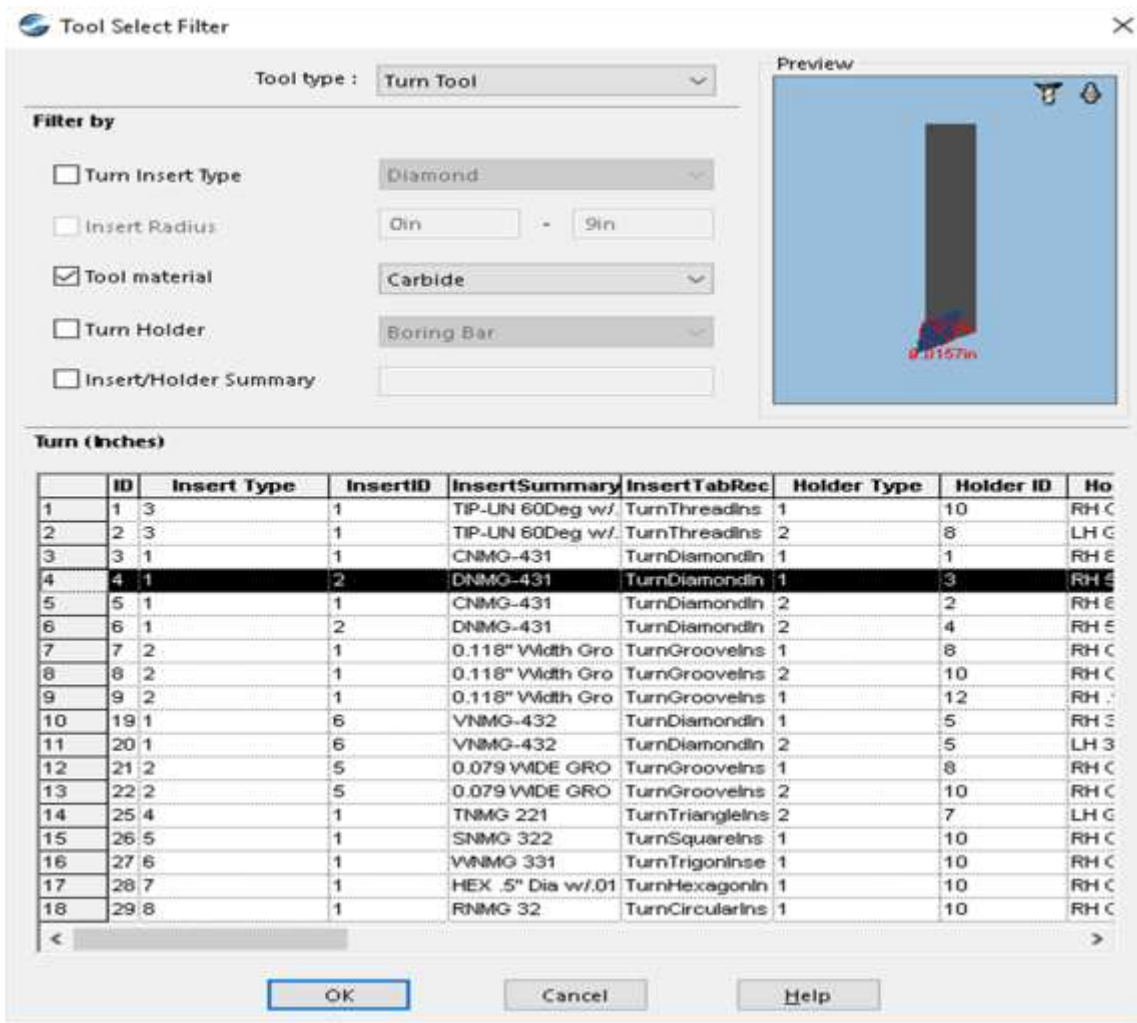

**Tool Select Filter dialog box**

**Note:** To exit without adding any tool using the Tool Select Filter dialog box, click on the Cancel button.

- A new tool selected to be added to the active tool crib using the Tool select Filter dialog box will be added to the bottom of the Active Tool crib. It can be viewed in the *Tool Crib* tab of the *Machine* node.



**Tool addition to the active tool crib is effective only for the current part. To make this tool addition available for all future jobs, click on the *Save Tool Crib* button to permanently save the changes.**

### Saving the changes made to a Tool

If you make changes to any tool in the active tool crib, the changes are effective only for the current part and not for any other part. The edits made to a tool to make available for all future jobs, highlight the tool in the *Active tool crib* grid and click on the *Save* button.

When you click *Save*, SOLIDWORKS CAM displays a message prompting you to select whether you wish modify the existing tool or add a new tool to the database.

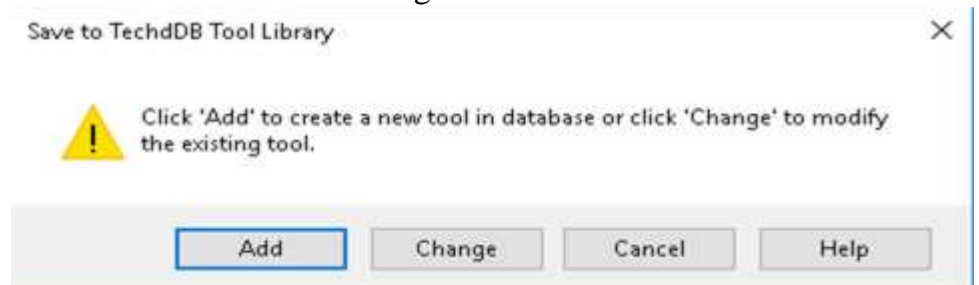

**Message displayed when you try to Save a Tool**

- If you select **‘Change’**, then the modifications made to the tool will be saved to the Technology Database, thus making them permanent. The modified tool will now be available for all future jobs.
- If you select **‘Add’**, then the original tool parameters and Tool ID of the edited tool will be retained. Instead, a new tool with the edited parameters will be created and saved to the Technology Database. The edited tool will continue to show the newly edited values. These values will be displayed only for the current part and not any future jobs. The newly created tool will not be visible in the *Active tool crib*. If you wish to add this new tool to the active tool crib, use the functionality of [Adding a tool](#) to add it.

### Selecting the Post Processor

- Click the *Post Processor* tab in the Machine dialog box.
- Make sure *T2AXIS-TUTORIAL* (the tutorial post processor) is selected as the active post processor.



**T2AXIS-TUTORIAL is used for the exercises in this manual. When you use SOLIDWORKS CAM to machine your own parts, select your machine tool controller or post processor.**

3. Click *OK* to apply the changes and close the *Machine* dialog box.

### Editing the Stock Definition

1. Double click *Stock Manager* in the SOLIDWORKS CAM Feature tree.

OR



Click on the *Stock Manager* button of the SOLIDWORKS CAM Command Manager.

The *Stock Manager* dialog box is displayed.

2. By default, the Stock shape is a cylinder whose dimensions enclose the part. For this tutorial, the part is machined from a bar stock that has **0.10in** material to be removed from the face. Hence, in the *Bar Stock Parameters* group box, change the *Stock Length* of the bar stock to **6.85in**.
3. Click *OK* to apply the changes and close the dialog box.

## Step 3: Extracting Machinable Features and Editing Feature Parameters

### Extracting Machinable Features

1. Click the *Extract Machinable Features* button on the SOLIDWORKS CAM Command Manager.

OR

Select the *Extract Machinable Features* command from the SOLIDWORKS CAM menu.

The SOLIDWORKS CAM Message Window is displayed. This window shows the progress of the process.

When Automatic Feature Recognition ([AFR](#)) is finished, the [Feature tree](#) displays the five machinable features recognized by AFR.



**Turn features recognized by AFR as listed in the Feature Tree**

## Turn Setup

Observe that AFR created *Turn Setup1*. The Setup defines the machining direction necessary to machine these features. The origin of the Setup is program zero for the Setup. By default, the origin is set to the front of the part.

For this tutorial, you will use the current machining direction.



By default, the origin of the Turn setup is set to the front of the part. You can change the machining direction using the *Edit Definition* command on the Turn Setup context menu. Tutorial [Turn 4](#) explains how to change this origin to another location.

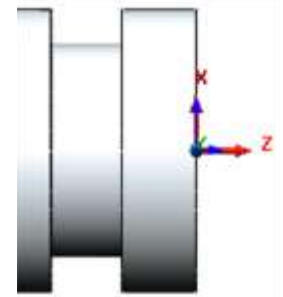

Origin of setup is set at the front of the part

2. Click each machinable feature in the Feature tree.

As you pick each machinable feature, the geometry for that feature is highlighted on the part.

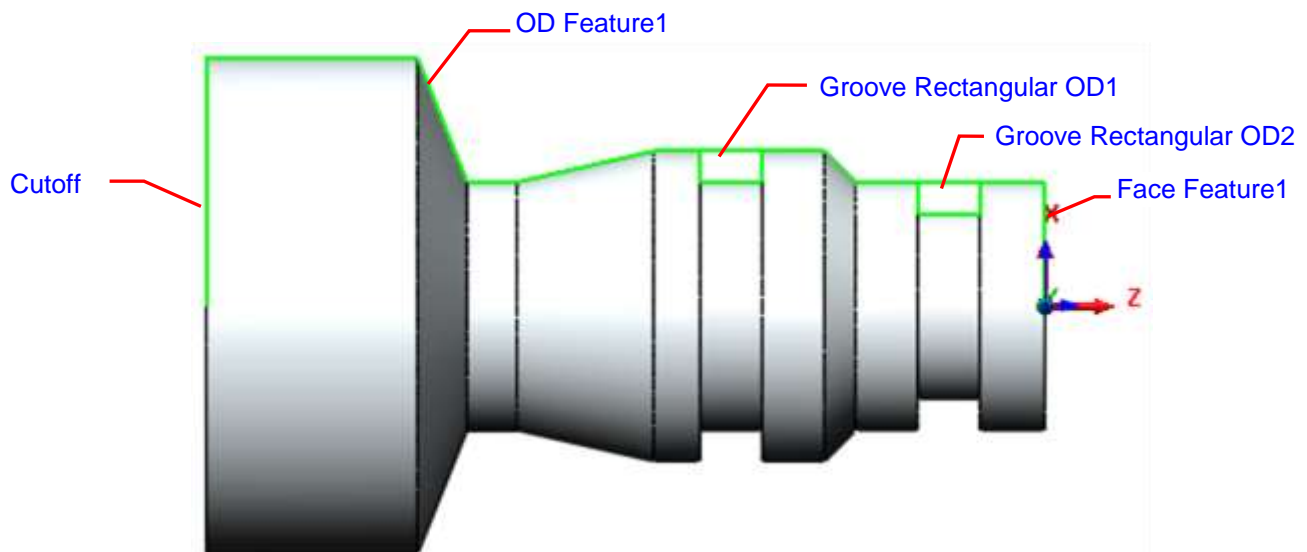

Turn features are highlighted on the part as you pick each feature in the Feature tree

## Feature Strategy

Machinable features are recognized based on the part's geometry (the shape of a feature) and topology (how the features are related to one another). However, not all attributes of a feature can be determined from the geometry and topography. For example, AFR cannot determine that an ID profile has been threaded, reamed or bored. SOLIDWORKS CAM allows you to specify additional Strategies to a feature so that more accurate operations can be created.

1. Right click on *OD Feature1* in the Feature tree and choose *Parameters* in the context menu.
2. The *Parameters* dialog box for the selected feature is displayed.  
This dialog box provides a geometric and dimensional report on the feature and allows you to assign additional information to the feature. Depending on the Strategy, a different machining process can be assigned. You can change how each feature is processed by defining the sequence in the Technology Database.
3. View the *Strategy* dropdown list.  
The Strategies in the list are user-defined Strategies that have been set up in the TechDB for other operation sequences. After you have learned how to use SOLIDWORKS CAM, you can modify or delete these user-defined Strategies and you can define additional Strategies to customize the TechDB.

**Note:** Whenever you select a Strategy from the Strategy dropdown list, the operations sequence and associated details will be displayed in a pop-up window next to the Feature Parameters dialog box.

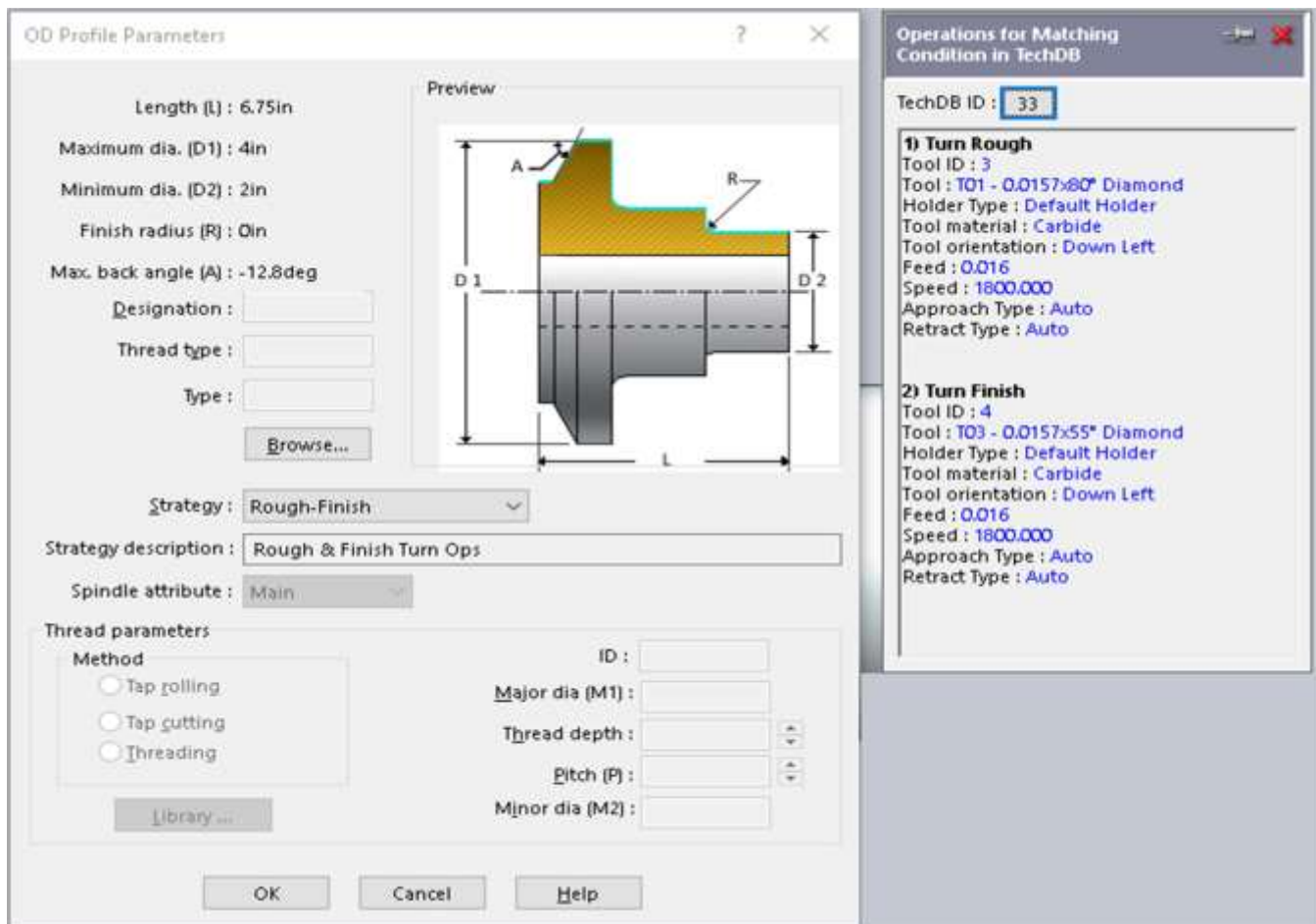

**Parameters Dialog Box with Pop-up window displaying operations for selected Strategy**

4. Leave the Strategy set to *Rough-Finish*.

This Strategy has been defined to generate Turn Rough and Turn Finish operations using an 80-degree and 55-degree diamond insert tool respectively.

5. Click *OK* to close the dialog box.
6. Review the parameters of other machinable features to understand more about the features.

## Step 4: Generating Operations

In this tutorial, you will first generate operations and toolpaths for *OD Feature1*, change its Feature strategy and then regenerate operations and toolpaths. After successfully generating toolpaths for *OD Feature1*, operations will be generated for the remaining turn features.



**Operations generated for OD Feature1**

1. Right click *OD Feature1* in the Feature tree and select *Generate Operation Plan* from the context menu.

The Operation tree lists Turn Rough and Turn Finish operations for the OD feature.

2. Left click the *Turn Rough1* operation in the Operation tree.

Notice the amount of material remaining after the Turn Rough operation. The back angle of the insert does not allow the tool to machine the entire feature.

In order to machine these areas, an additional Turn Rough operation need to be interactively inserted to machine the leftover material.

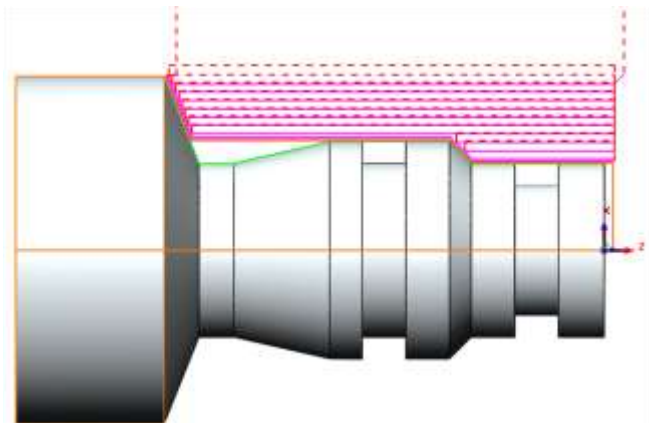

**Turn Rough Toolpath for OD Feature1**

### 3. Steps to insert Turn Rough operation interactively

- In the SOLIDWORKS CAM Operation tree, right-click on the *Turn Rough1* operation and select *Turning Operations>>Turn Rough* from the context menu.

The *New Operation: Turn Rough* dialog box will be displayed.

- In the Tool group box, click on the dropdown list and select *Rear Turret*.
- The Tool dropdown list becomes active. Select the *T03 – 0.0157x55.0000deg Diamond* tool.
- Click *OK* to insert the operation.

- The *Operation Parameters* dialog box will be displayed. Click *OK* to close this dialog box.

Observe that the *Turn Rough2* operation has been added to the Operation tree.

The Operation tree now lists three operations for *OD Feature1*.

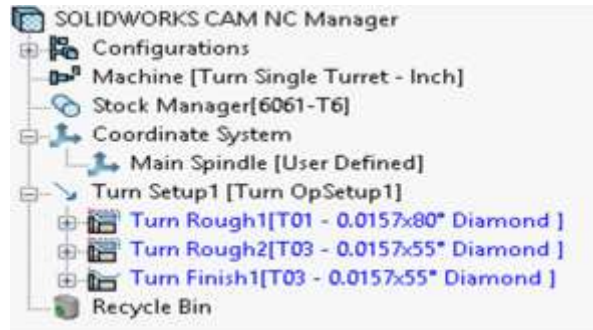

Operations for OD Feature1

- Right click *Turn Setup1* in the Operation tree and select *Generate Toolpath* from the context menu. Alternatively, you can click on the *Generate Toolpath* command on the SOLIDWORKS CAM Command Manager.

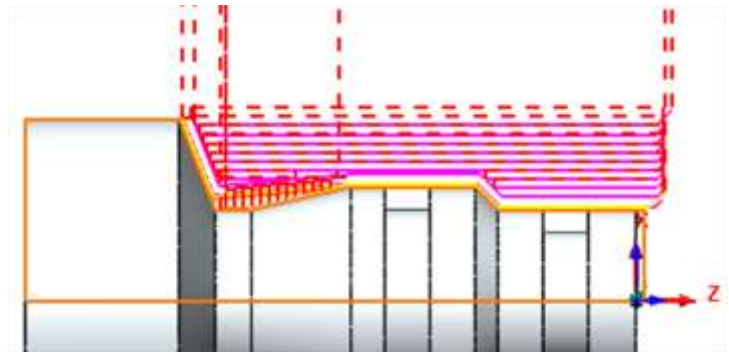

Toolpaths to machine OD Feature1

- Press the *Shift* key and select all the operations listed in the Operation tree.

The toolpaths generated are displayed in the graphics area. Observe the toolpaths for the Turn rough operation. These toolpaths ensure that there is no material leftover.

- Click the *SOLIDWORKS CAM Feature Tree* tab to return to the Feature tree.
- You now need to generate operations for the remaining four features in the Feature tree.

Click the *Generate Operation Plan* button on the SOLIDWORKS CAM Command Manager.



Operations regenerated for OD Feature1

8. The *Generate Operation Plan* message window is displayed again. Click either *Update* or *Regenerate*. The operations generated when you click either button will be the same.

The Operation tree now contains operations for all machinable features in the Turn Setup.

9. Reorder the operations so that the *Face Rough1* and *Face Finish1* operations are at the top of the list.

- If you have not changed any machining parameters for the operations that have already been generated, you can select either *Regenerate* or *Update*.
- If you have modified the operations, select *Regenerate* to delete all previous operations and generate new operations for all the features.
- If you have modified the operations, select *Update* to generate operations only for those features that do not have operations.

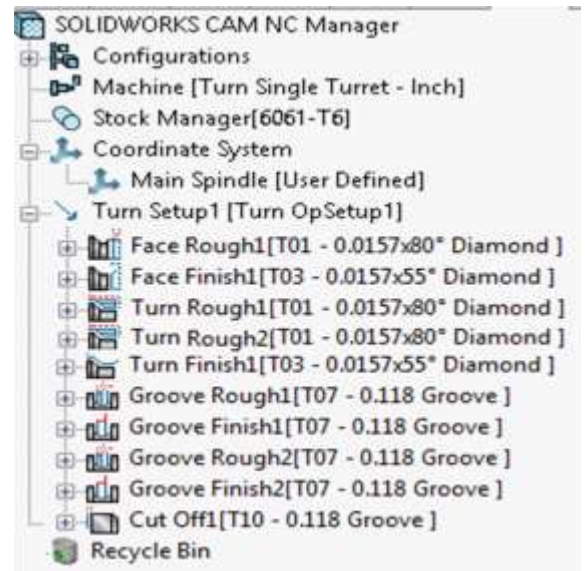

Operations generated for all machinable features

10. Click on the *Generate Toolpath* button on the SOLIDWORKS CAM Command Manager.

## Step 5: Generating NC Code

To generate the NC code for this part, you must:

- Adjust the operation parameters as required
- Reorder the operations in the tree if necessary (Refer [Step 8-b](#) of Tutorial 1)
- Generate toolpaths (Refer [Step 7](#) of Tutorial 1)
- Run the Toolpath Simulation (Refer [Step 8](#) of Tutorial 1)
- Readjust operation parameters if necessary
- Post process the part (Refer [Step 9](#) of Tutorial 1)



### Did You Know ...

Depending on your machining preferences, you could delete the OD feature and the two rectangular groove features found by AFR, then interactively insert an OD feature that includes the grooves. This feature can be machined completely with the operations generated by the RF80-GR Strategy.



The [next tutorial](#) explains how to insert Turn features interactively.



## Turn 3

### Topics covered in this tutorial:

- [Inserting an OD Profile for Threading](#)
- [Reorganizing Machinable Features](#)
- [Suppressing Machinable Features](#)
- [Significance of the SOLIDWORKS CAM Message Window](#)
- [Viewing XZ coordinates of the tool in the SOLIDWORKS CAM Message Window](#)
- [Post Processing Toolpaths](#)



In this tutorial, assume that the part starts out as a casting and machining is required only for the features up to the larger diameter.

In *Turn Setup1*, you will perform a facing operation on the part model, Rough and Finish operations for its OD profile; Rough and Finish operations for its rectangular grooves, and a CutOff operation to separate the machined part from the stock.

### Step 1: Open the Part, Define the Machine, Edit the Stock Definition and Extract Machinable Features

1. Open part file **TURN2AX\_3.SLDPRT** in the following folder.

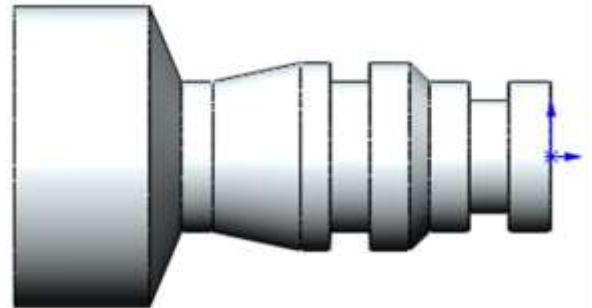

*C:\Users\Public\Public Documents\SOLIDWORKS\SOLIDWORKS 201x\CAM Examples\Tutorial\_Parts\Turn*

2.  Click the *SOLIDWORKS CAM Feature Tree* tab.
3. Under this tree, observe that *Machine [Mill - inch]*  is the active machine. In this tutorial, the part will be machined on a Single Turret Turn machine.





**TURN2AX\_3.SLDPRT**

#### Define the Machine Parameters

1.  Double click the *Machine* item in the Feature tree. OR  
 Click on the *Define Machine* button on the SOLIDWORKS CAM Command Manager. The *Machine* dialog box is displayed.
  - In the *Machine* tab of this dialog box, highlight *Turn Single Turret- inch* in the list of *Available machines* and click the *Select* button. (This action will replace the currently active Mill machine listed in the Feature tree with the Turn machine you have selected when you close this dialog box by clicking the *OK* button.)
  - Click the *Tool Crib* tab, ensure *Tool Crib 2 Rear (Inch)* is the active tool crib.

- Click the *Post Processor* tab make sure *T2AXIS-TUTORIAL* is selected.
- Click *OK* to apply the changes and exit the *Machine* dialog box.

### Editing the Stock Definition

1. Double click *Stock Manager* item in the Feature tree. OR  
 Click the *Stock Manager* button in the SOLIDWORKS CAM Command Manager. The *Stock Manager* dialog box will be displayed.
2. In the *Bar stock parameters* group box, change the Stock Length of the bar stock to **6.85in**.  
 By default, the Stock shape is a cylinder whose dimensions enclose the part. For this tutorial, the part is machined from bar stock that has **0.10in** material to be removed from the face. Assume that the largest OD of the part is to size and is not machined in this Setup. Since SOLIDWORKS CAM currently defines the Stock as round bar stock, you will use the default round shape and offset the minimum Stock size by **0.10in** in length.
4.  Click *OK* to apply the changes and close the dialog box.

### Extract machinable Features

1.  Click the *Extract Machinable Features* button on the SOLIDWORKS CAM Command Manager. OR  
 Right click *SOLIDWORKS CAM NC Manager* in the Feature tree and select *Extract Machinable Features* from the context menu.  
 On executing this action, AFR creates *Turn Setup1*. It recognizes five features and lists them in the Feature tree.

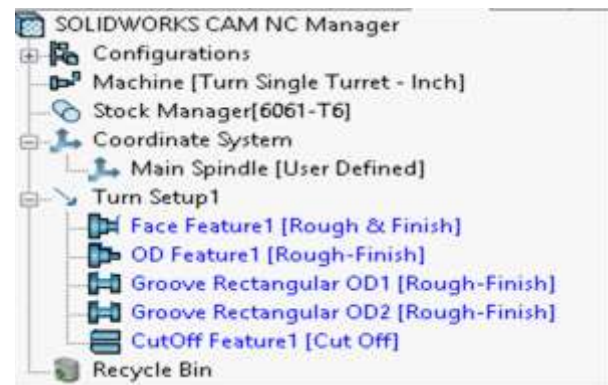

**Turn features recognized by AFR as listed in the Feature Tree**

## Step 2: Interactively Inserting an OD Profile for Threading

Now that a Turn Setup has been defined, you can create an OD profile feature to thread the part. This OD feature with thread will be inserted interactively using the *Turn Feature* command.

1. Right click *OD Feature1* in the Feature tree and select *Turn Feature* from the context menu.  
 The *New Turn Feature* dialog box is displayed. The part profile is shown in the graphics area. Notice that as you move your cursor over the profile, the entities change color and are highlighted.
2. In the *Features* group box of this dialog box, assign the following parameters:

- Select *OD Feature* for Type.
  - Click on the dropdown list for *Strategy* and select *Thread*.  
(The Thread Strategy has been defined in the TechDB to generate a thread operation.)
3. Since the part does not contain any non-revolved features, leave the *Part Profile Method* set to *Plane Section*.
  4. In this tutorial, we will interactively define a feature picking the segment(s) on the highlighted geometry of the part. Hence, in the *Define from* group box, leave the method set to *<Part Profile>*.
  5. Turn features can be defined by an outside shape and optionally inside shapes to represent profiles. These shapes can be



#### Pick the first OD profile Segment

sketches or part profiles that are normal to the current Setup.

- In the graphics area, pick the *OD profile* segment on the right at the part face to select it. The single segment is highlighted.
  - The selected segment (face) will be listed in the *Selected entities* list box of the dialog box as *CW Face-1*. *Extend 1* and *Extend 2*, which are parameters used to determine how the toolpath is computed at the ends of the feature, are also listed in this box.
6. Make sure that *Extend1* and *Extend 2* are set to *None* in their respective group boxes.

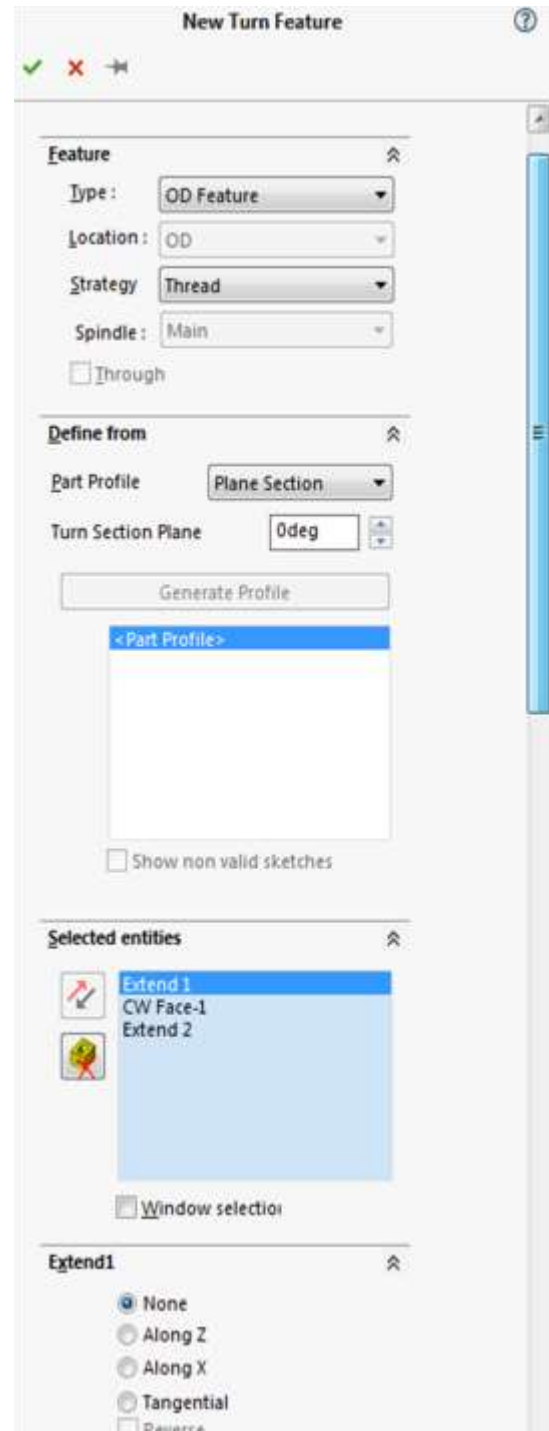

**New Turn Feature Dialog box**



If SOLIDWORKS CAM is calculating the *Work In Process (WIP)*, then the ID and OD Thread features should not be extended in either Z or X direction. If you extend the Thread features, SOLIDWORKS CAM determines the feature length relative to the WIP and may extend the feature to start threading closer to the face than you want. Typically, this would occur when the thread feature is not located at the face of the part.

7. Click *OK* to insert the feature and close the *New Turn Feature* dialog box.

A feature labeled *OD Feature2* is displayed in the Feature tree under *OD Feature1*. You have now defined all the machinable features in this part.

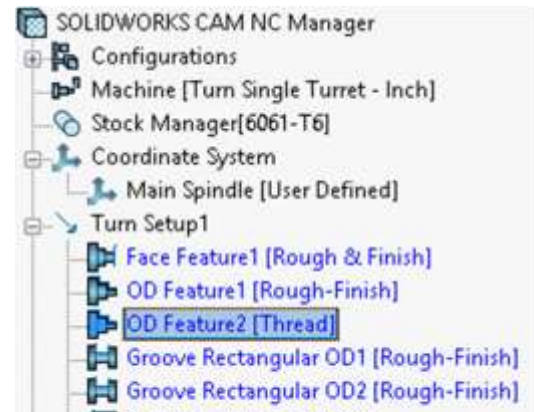

**OD Feature2 in Feature Tree**

### Step 3: Reorganizing Machinable Features

To change the machining order, you can reorder either the machinable features or the operations that are generated for the features. You can drag a feature in the Feature tree from the current location to a position above or below another feature in the same Setup.

1. Left click *Groove Rectangular OD1*, then click *Groove Rectangular OD2*. Observe the order the grooves are highlighted on the part model in the graphics area.  
This may not be the order you want to machine these features.
2. Highlight *Groove Rectangular OD2*; hold down the left mouse button and drag and release it over *OD Feature2*.

Notice that as you drag the item, an arrow displays to indicate where the item will be positioned. *Groove Rectangular OD2* will now be listed before *Groove Rectangular OD1* and will be machined first.



**Reorganized list of Machinable Features**

## Step 4: Suppressing Machinable Features

You can suppress a machinable feature and machine the feature later. Suppressing a feature prevents operations (and associated toolpaths) from being created for that feature. For example, if there is not enough tool capacity to do threading on the machine which you are using, you can suppress *OD Feature2* and output the thread operation separately.

1. Right click *OD Feature2* in the Feature tree and select *Suppress* on the context menu. This action grays out *OD Feature2* icon in the tree.



**Suppressed OD Feature2**

## Step 5: Saving the File

1. Click on the *File* menu and select *Save As* on the dropdown menu.
2. The *Save As* dialog box is displayed. Browse to the location where you wish to save the file.
3. If you wish to save the file with another name rather than the default name, assign another file name
4. Click the *Save* button.

## Step 6: Generating an Operation Plan and Toolpaths

1.  Click the *Generate Operation Plan* button on the SOLIDWORKS CAM Command Manager.

OR

Right click *SOLIDWORKS CAM NC Manager* in the Feature tree and select *Generate Operation Plan* on the context menu.

Operations are created for the machinable features in the Turn Setup.

The generated operations are in listed in the Operation tree.

2. Click on the  sign against each operation listed in the Operation tree to view the feature machined by that selected operation. Observe that no operations were generated for *OD Feature2* as this feature was suppressed.

3.  Click the *Generate Toolpath* button on the SOLIDWORKS CAM Command Manager.  
OR

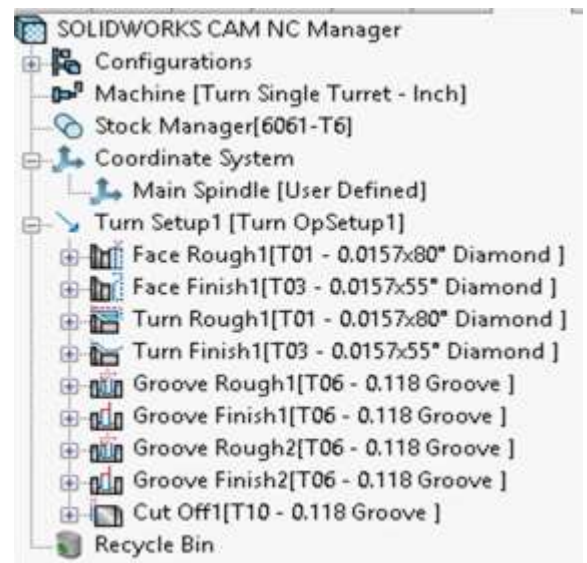

**Operations with toolpaths generated for all Turn features listed in the Operation tree**

Right click *Turn Setup1* in the Operation tree and select *Generate Toolpath* from the context menu.

The change in the font color of the listed operations from **Blue** to **Black** (default color settings) indicates that toolpaths have been generated for all operations.

4. Experiment by changing parameters for the operations and regenerating the toolpaths for all operations in the Setup.



#### **Did You Know ...**

**When you change operation parameters after generating toolpaths, we recommend that you regenerate toolpaths at the Setup level so the work in process can be updated correctly.**

### **SOLIDWORKS CAM Message Window**



Check the SOLIDWORKS CAM Message Window.

- This SOLIDWORKS CAM window displays automatically whenever SOLIDWORKS CAM commands such as *Extract Machinable Features*, *Generate Operation Plan*, *Generate Toolpath* etc. are executed.

- The Message Window provides information you may find helpful. For example, based on the information in this window, you may want to change a tool or insert a finish operation in order to cut a machinable feature completely.

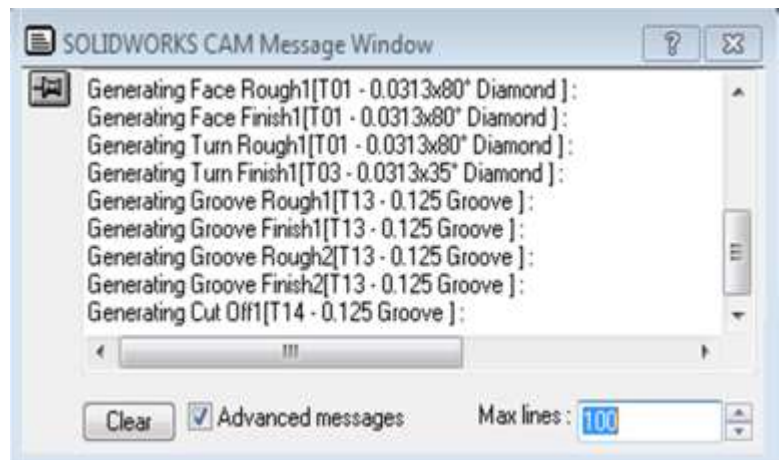

**SOLIDWORKS CAM Message Window**

- If the Message Window is not displayed, you can do any one of the following to display the Message Window:

- Select *Options* on the SOLIDWORKS CAM menu or the *SOLIDWORKS CAM NC Manager* context menu. The Options dialog box will be displayed. On the *General* tab, check the *Message Window* check box.





- Click on the *Message Window* button on the SOLIDWORKS CAM Command Manager.

- You can move and resize the window. To change the size, point to a border or corner of the window (the pointer changes to a two-headed arrow). Drag the corner or border until the window is the size you want and then release the mouse button.
- For turn parts, SOLIDWORKS CAM provides an option to display the XZ position of the tool in the Message Window during simulation. How to use this functionality is explained

in the Step 7 of this tutorial in the section [Viewing XZ Cutter coordinates of the Tool in the Message Window](#).



## Step 7: Simulate Toolpaths

-  Click the *Simulate Toolpath* button on the SOLIDWORKS CAM Command Manager. OR  
 Select *Simulate Toolpath* from the SOLIDWORKS CAM menu.  
 OR  
 Right click *SOLIDWORKS CAM NC Manager* in the Operation tree and select *Simulate Toolpath* on the context menu.
- The *Toolpath Simulation* toolbar is displayed. The graphics area enters Simulation mode.
- Select the following display options:

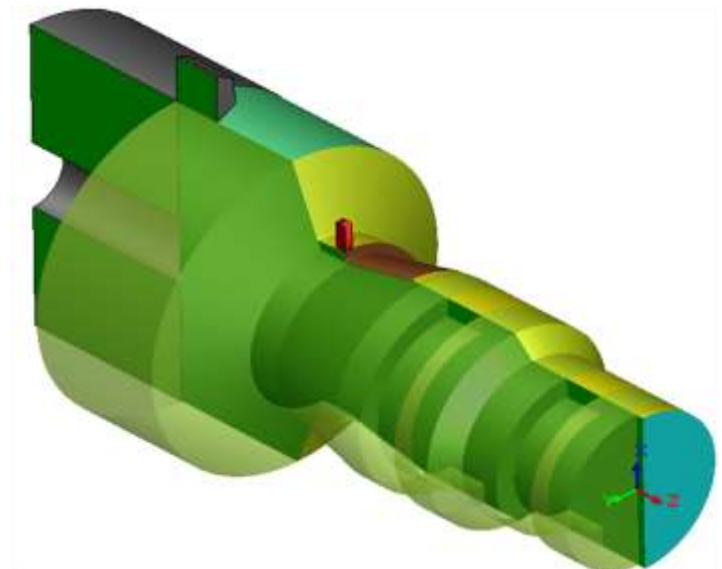
-  Stock: *Shaded Display*
-  Tool: *Shaded with Edges Display*
-  Tool Holder: *No Display*
-  Target Part: *Translucent Display*
-  Fixture: *Shaded with Edges*
-  Section View: *Half*



**Running Toolpath Simulation**

- Rotate the part, if necessary, so that you can see the simulation.
-  Click the *Run* button.
-  Click the close button in the upper right corner of the *Toolpath Simulation* toolbar to exit Simulation mode.

## Viewing XZ cutter coordinates of the Tool in SOLIDWORKS CAM Message Window

For turn and mill parts, SOLIDWORKS CAM provides an option to display the XZ position of the tool in the Message Window during toolpath simulation. To view the coordinates,

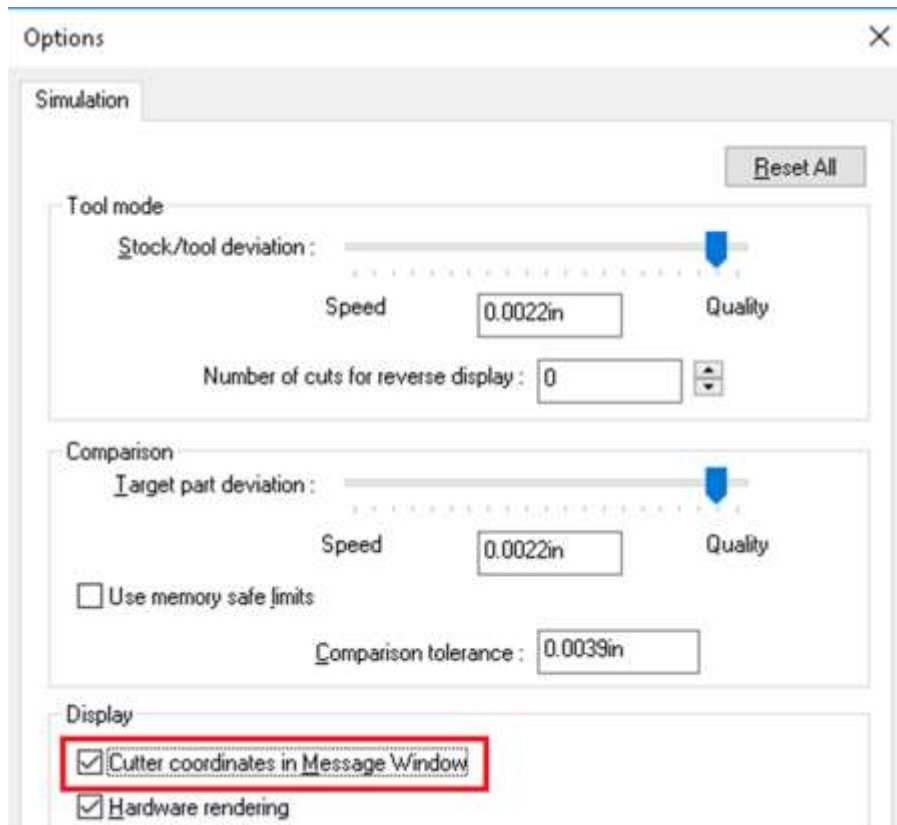

-  Click on the *Options* button in the *Toolpath Simulation* toolbar.

- The Simulation Tab of the Options dialog box is displayed. In the Display group box, ensure that the option *Cutter Coordinates in Message Window* is checked.
- Click *OK* to close the *Options* dialog box.



**The Simulation tab of Options dialog box**

- Click *Yes* to restart the Simulation mode when SOLIDWORKS CAM prompts a warning message in order to apply the new simulation settings.

-  In the Simulation toolbar, click the *Cutter coordinates* button.
-  The X coordinate is displayed as a Radial value by default. Click on the *Radial or diameter coordinate display* button to view the X coordinate as a diameter value.
-  The XZ coordinates are output to the tool center by default. To output these coordinates to the theoretical Tool Tip, click on the *Tip or center*

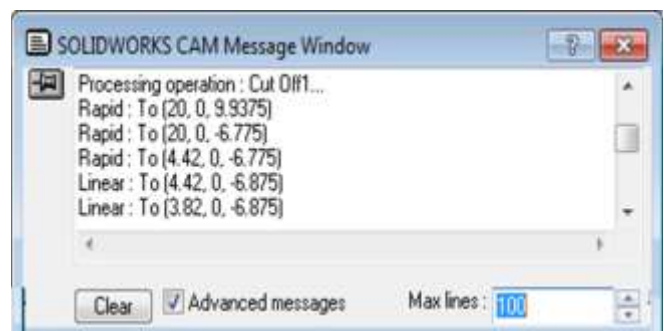

**SOLIDWORKS CAM Message Window displaying XZ**



*coordinate display* button.

8. Run the Simulation. Observe that the XZ coordinates of the tool are output in the SOLIDWORKS CAM Message Window.

## Step 8: Post Processing Toolpaths

1.  Click the *Post Process* button on the SOLIDWORKS CAM Command Manager.  
OR  
Right click *Turn Setup1* in the Operation tree and select *Post Process* from the context menu.  
OR  
Click the *Post Process* on the SOLIDWORKS CAM menu.
2. The *Post Output File* dialog box is displayed. Browse to the folder where you wish to save the file.



**If you are running SOLIDWORKS CAM in Demo mode, the Post Process functionality will be disabled.**

3. If you do not wish to save the file with the default file name, assign another file name in the *File name* field.
4. Click *Save* to save the file.
5. The *Post Process Output* dialog box is displayed. In the Options group box, check the *Centerline* option so that the toolpath will be highlighted as each line of code is generated.
6.  Click the *Play* button.  
This command generates the NC code. The generated NC code can be viewed in the *NC code output* area of the dialog box.
7. After viewing the code, click OK to close the dialog box.



### **Did You Know ...**

**You should save the part frequently. If you want the CAM information saved with the part, make sure that the Save/Restore part option is checked on the General tab in the Options dialog box before you save. When you open the part, make sure that Save/Restore is checked or the CAM information will not be restored.**

**The General tab in the Options dialog box also has an Auto save option for automatically saving your SOLIDWORKS CAM data.**

## Turn 4

### Topics covered in this tutorial:

- [Defining the Stock as a Forging or Casting](#)
- [Defining a Rectangular OD Groove Feature interactively](#)
- [Deleting an Operation](#)
- [Adjusting Operation Parameters](#)
- [Defining Program Zero](#)



This tutorial guides you through the steps for the sequence of machining the turn part when the stock is defined from a forging or casting. The machining sequence is:

- Rough and finish the face of the part
- Rough and finish the OD profile
- Rough and finish the groove

### Step 1: Open the Part and Define the Machine

1. Open part file **TURN2AX\_4.SLDPRT** in the following folder.

*C:\Users\Public\Public Documents\SOLIDWORKS\SOLIDWORKS 201x\CAM Examples\Tutorial\_Parts\Turn*

2.  Click the *SOLIDWORKS CAM Feature Tree* tab.
3. Under this tree, observe that *Machine [Mill- inch]*  is the active machine. In this tutorial, the part will be machined on a Single Turret Turn machine.
4.  Double click the *Machine* item in the Feature tree.

OR

 Click on the *Define Machine* button on the SOLIDWORKS CAM Command Manager. The *Machine* dialog box is displayed.

- In the *Machine* tab of this dialog box, highlight *Turn Single Turret- inch* in the list of *Available machines* and click the *Select* button. (Executing this command replaces the currently active Mill machine listed in the Feature tree with this selected Turn machine when you close this dialog box by clicking on the OK button.)
- Click the *Tool Crib* tab, ensure *Tool Crib 2 Rear (Inch)* is the active tool crib.
- Click the *Post Processor* tab and make sure *T2AXIS-TUTORIAL* is selected.
- Click *OK* to apply the changes and exit the *Machine* dialog box.

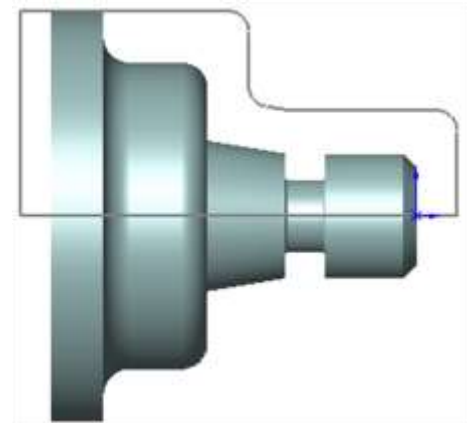

**TURN2AX\_4.SLDPRT**

## Step 2: Defining the Stock as a Forging or Casting

In this tutorial, assume that the stock of the part is a forging. A sketch named *Stock Profile* has already been created in this part to represent the forging.

1. In the Feature tree, double click the *Stock Manager* item to open the *Stock Manager* dialog box.

OR

Click the *Stock Manager* button in the SOLIDWORKS CAM Command Manager.

By default, SOLIDWORKS CAM automatically calculates the Stock size based on the smallest cylinder possible. (Default Stock Type: *Round Bar Stock*). You can change this definition by specifying a sketch to use (Stock Type: *From Revolved Sketch* ).

2. Select *From Revolved Sketch* for the Stock type.
3. In the *Available sketches* list, select *Stock Profile*.

The profile sketch representing the shape of the stock is highlighted on the part model in the graphics area.

4. Click *OK* to apply the changes and close the *Manage Stock* dialog box.



**Stock Manager dialog box**

## Step 3: Recognizing Machinable Features using AFR

Click the *Extract Machinable Features* button on the SOLIDWORKS CAM Command Manager. OR

Select *Extract Machinable Features* from the SOLIDWORKS CAM menu.

OR

Right click *SOLIDWORKS CAM NC Manager* in the Feature tree and select *Extract Machinable Features* from the context menu.

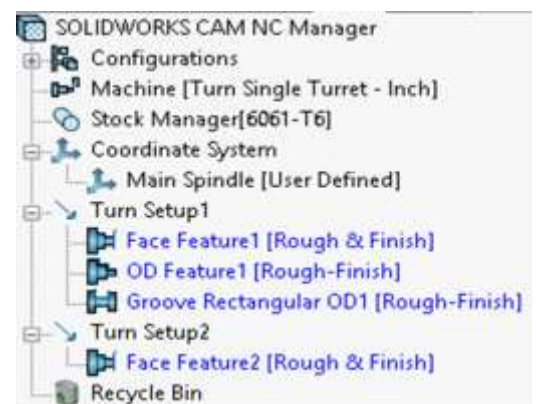

**Rectangular OD groove feature recognized by AFR**

**AFR** creates *Turn Setup1* and *Turn Setup2* and lists all the recognized features in Feature tree. The recognized features under *Turn Setup1* include a Face Feature, an OD Feature and a Rectangular OD groove.

*Turn Setup2* is created as a separate setup for the second side of the part, which includes a Face feature.



**When the Stock is defined from a sketch, SOLIDWORKS CAM creates a second setup with a Face feature.**

### Deleting Unwanted Features Recognized by AFR

When AFR is run on some parts, all the features you want to machine might not be recognized. In certain cases, AFR may recognize a feature that might not be suitable for the intended machining process. When this occurs, you can delete unwanted features and define features interactively.

For learning purposes, in this tutorial, you will delete the *Rectangular OD groove* feature and insert the same feature interactively.

1. Right click *Groove Rectangular OD1* in the tree and select *Delete* on the context menu.
2. Click *Yes* to confirm the deletion.  
The deleted feature is moved to the Recycle Bin.
3. Click the  sign to the left of the Recycle Bin in the Feature tree to collapse it.



**Deleted features are automatically placed in the Recycle Bin, which is used to store machinable features that you do not intend to machine.**

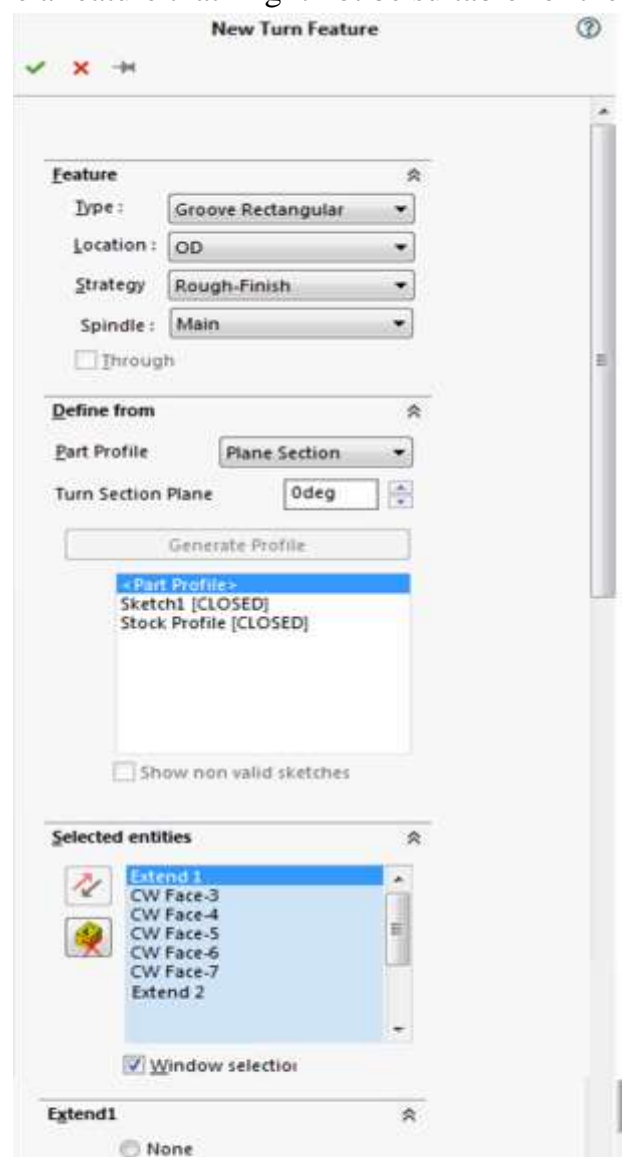

**New Turn Feature Dialog box**

### Step 4: Defining a Rectangular OD Groove Feature Interactively

Following are the steps to interactively insert a *Rectangular OD groove* feature. This feature is defined in order to machine the undercut.

1. Right click *OD Feature1* under *Turn Setup1* in the Feature tree and select *Turn Feature* from the context menu.

The New *Turn Feature* dialog box is displayed.

2. In the *Feature* group box:
  - Set the Feature Type to *Groove Rectangular*.
  - Leave the Location set to *OD*.
  - Make sure the Strategy is set to *Rough-Finish*.
3. In the *Define from* group box,
  - Ensure that the Part Profile Method is set to *Plane Section*.



If the part does not contain any non-revolved feature(s), then you can set the Part Profile method to either *Plane Section* or *Revolved Section*. The Part Profile created in both cases will be the same. Ideally:

- Use *Plane section* method when the part does not contain any non-revolved features
  - Use *Revolved section* method when the part contains non-revolved features or mill features.
- In the list box, ensure *<Part Profile>* is selected.



When *<Part Profile>* is selected in the Define From list box, all profiles in the current section plane are highlighted on the model in the graphics area. The profiles recognized are based on the *Part Profile Method* selected.

4. In the *Selected entities* list box,
  - Check the *Windows selection* check box.
  - In the graphics area, use the mouse to select the geometry for the groove by drawing a window around the groove entities as shown in the figure on the right.
  - The *Selected entities* list box will be updated to contain 5 selected faces entities and 2 extent entities.
  - Highlight *Extendd1* in the *Selected entities* list box.

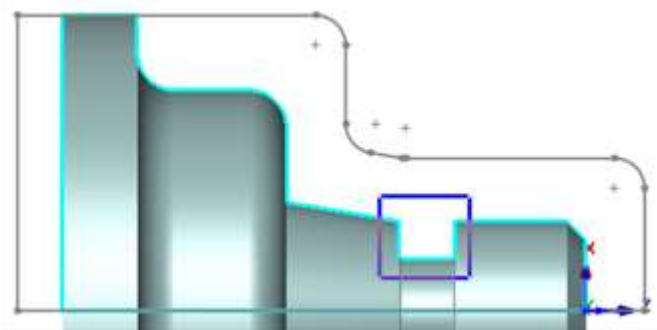

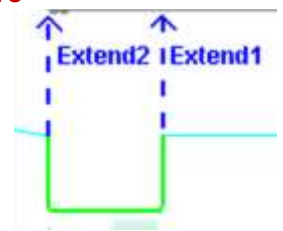

Window Select the Rectangular OD Groove Feature



Extents

- The *Extend1* and *Extend2* group boxes will be expanded.
- In the *Extend1* group box, set the direction to *Along X*.
- In the *Extend2* group box, set the direction to *Along X*.

The extents will be displayed on the model part in the graphics area.

5.  Click *OK* to insert the feature.  
*Groove Rectangular OD2* is added to the Feature tree.
6.  Click the *Generate Operation Plan* button on the SOLIDWORKS CAM Command Manager.

OR

Right click *SOLIDWORKS CAM NC Manager* and select *Generate Operation Plan* from the context menu.

The operations for *Turn Setup1* and *Turn Setup2* are listed in the SOLIDWORKS CAM Operation tree.

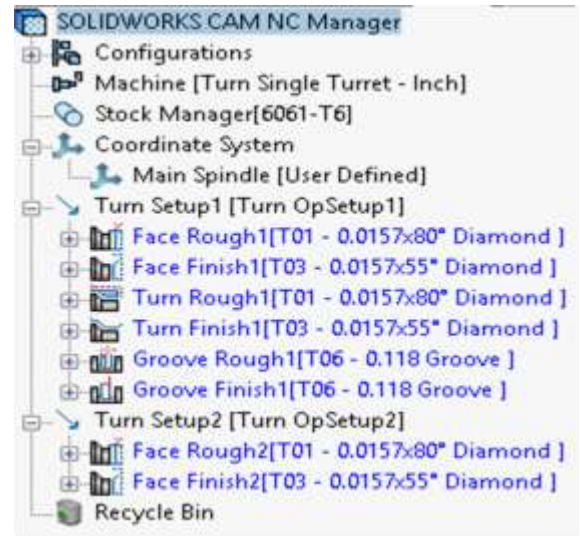

**SOLIDWORKS CAM Operation Tree**

## Step 5: Deleting an Operation

In some cases, it may be desirable to delete operations that are created automatically. In this tutorial, all of the operations that were generated for *Turn Setup1* are required to machine the part.

If the stock is a casting or forging and you use a sketch to define the Stock, SOLIDWORKS CAM generates a second setup for the other side of the part. Depending on whether or not a second setup is needed for this machining session, you can delete or suppress the operations that were generated for *Turn Setup2*. In this tutorial, you will delete the second setup and all the operations under it.

1. In the Operation tree, right click *Turn Setup2* and select *Delete* on the context menu.
2. Click *Yes* to confirm you want to delete the Setup and all dependent operations under it.

The Setup is deleted and the operations are moved to the *Recycle Bin*.

3. Click the  sign to the left of the Recycle Bin in the Operation tree to collapse it.

## Step 6: Adjusting Operation Parameters

Each operation contains machining parameters that affect how the toolpath is created and specific parameters that will be output to the NC program. These parameters can be edited before generating the toolpaths and post processing the part.

1. Click the  sign next to *Face Rough1* in the Operation tree.



**Expanding the tree**

The tree expands to identify the machinable feature the operation was generated to machine (*Face Feature1*).

2. Click the  sign next to *Face Rough1* in order to collapse it.
3. Double click *Face Rough1*.

The Operation Parameters dialog box is displayed. In the Operation Parameters dialog box:

- Click on the *NC* tab.
- Within the *Clearance* group box, change the *Retract dist.* to **0.15in.**

This parameter specifies the distance away from the part to start the cycle in the X and Z axis. This is where the tool rapids to at the beginning of the cycle and the distance the tool retracts from the part after each cutting pass.

- Click *OK* to apply the changes and close the dialog box.

## Step 7: Displaying the Chuck in Graphics Area

You can choose to display the chuck in the graphics area in any one of the following display states:

- None (*no display*)
- Wireframe
- Translucent
- Shaded
- Shaded with Edges

In this tutorial, you will display the chuck in a *Shaded with edges* display state.

### Following are the steps to display the chuck:

1. Switch to the Operation tree.
2. Right click the machine item *Machine [Turn Single Turret-inch]* in the Operation tree and select *Chuck Display>>Shaded with Edges* from the cascading context menu.
3. Once again, right click on this item and ensure that *Chuck Display>>Machine Node* and *Chuck Display>>Setup Node* options in the cascading context menu are checked.

To check/uncheck this option, left click on the desired option in the cascading menu.

The above action ensures that the chuck is displayed whenever the Machine item or Turn Setup is selected in the Operations tree.

## Step 8: Defining Program Zero

Each Setup has a different origin. The Turn Setup defines the tool direction and Program Zero. Program Zero can be changed in the Setup by picking one of the following that is closest to the desired work *Z0* face:

- An OD that is concentric to the part. OR
- Angle that is concentric to the part. OR

- ID face that is concentric to the part.

**Following are the steps to change the Program Zero:**

1. Double click *Turn Setup1* in the Operation tree.  
The *Operation Setup Parameters* dialog box is displayed.
2. Click on the *Origin* tab.
3. Select the *Part Vertex* option. The image that allows you to select the desired part vertex will be enabled within this tab. Select the part vertex as shown below.

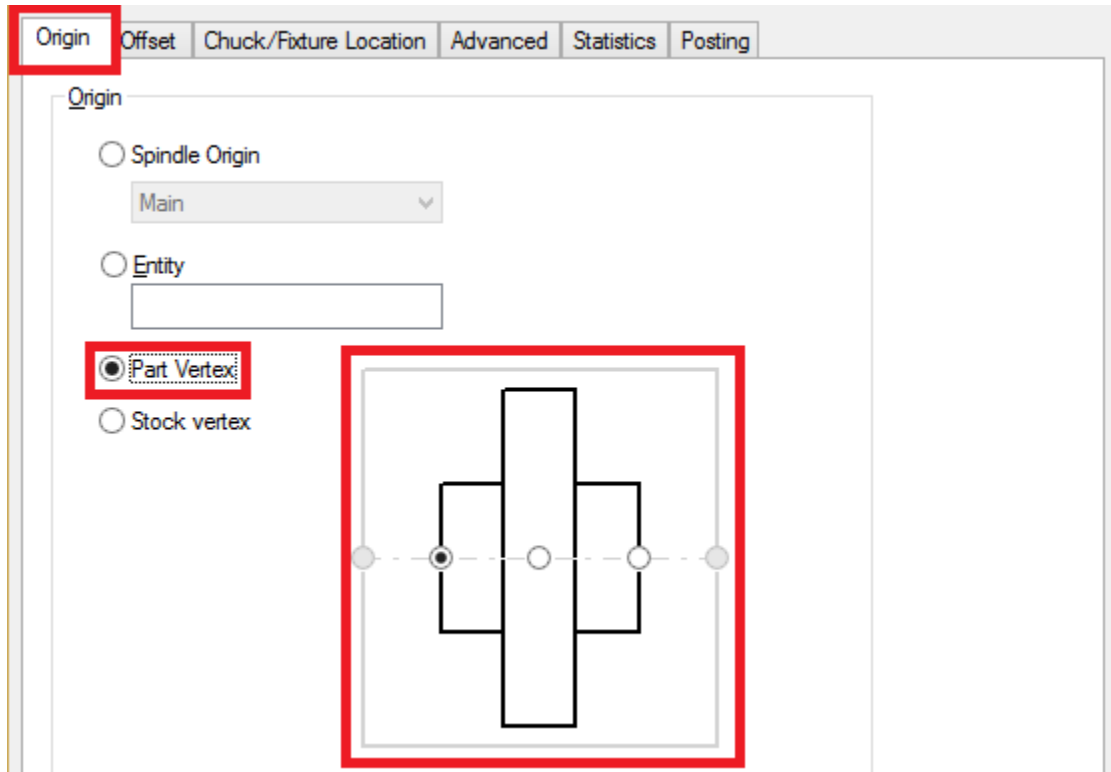

**Selecting Part Vertex as Origin in Origin tab of Operation Setup Parameters dialog box**

4. Click *OK* to apply the changes and close the dialog box.  
The *Chuck Location* and *Chuck Definition* tabs in this dialog box will be explained in the next chapter of this guide.



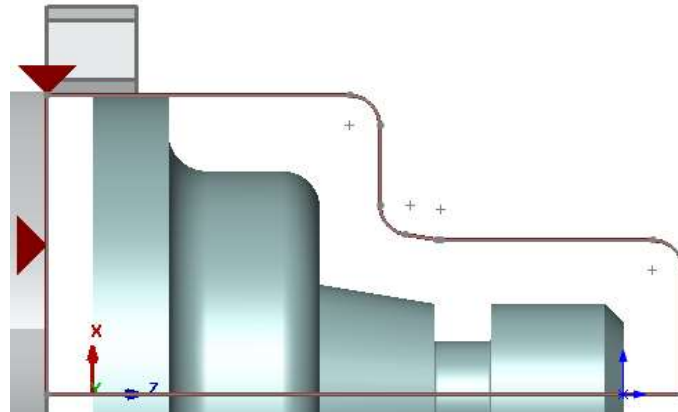

**Change in Origin when defined as 'Part Vertex'**

- Click on the *Yes* button if you get a pop-up message prompting you to regenerate the toolpaths.

OR

 Click the *Generate Toolpath* button on the SOLIDWORKS CAM Command Manager.

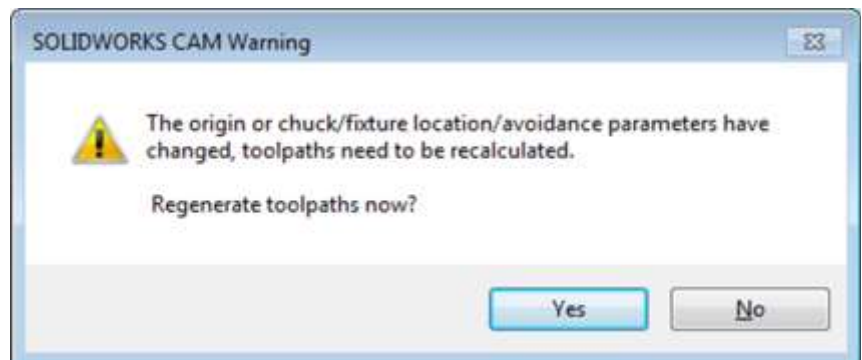



**Warning message to regenerate toolpaths**

Toolpaths are generated for all operations.



- Click each operation in the tree to view the toolpaths.

## Step 9: Simulate Toolpath

-  Click on the View Orientation and select  the *Isometric* view orientation.
- Right click *Turn Setup1* and select *Simulate Toolpath* from the context menu.



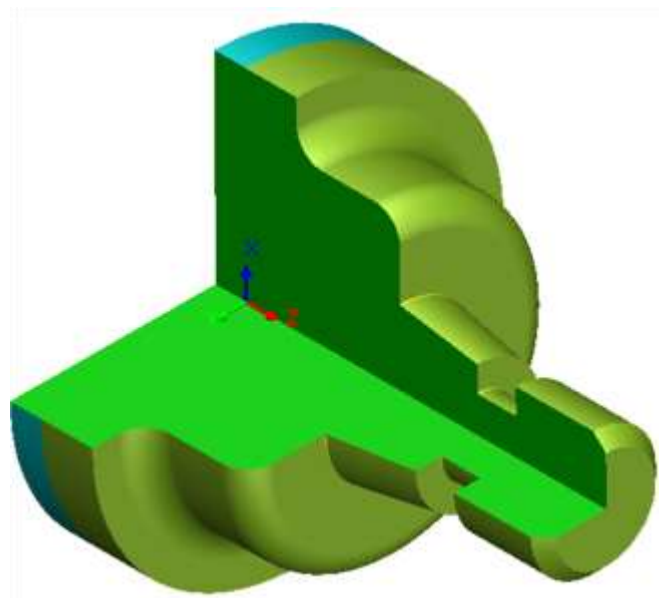

The Toolpath Simulation toolbar is displayed.

- Select the following display options:

-  Stock: *Shaded Display*
-  Tool: *Shaded with Edges Display*
-  Target: *Translucent Display*



**Toolpath Simulation**

-  Fixture: *No Display*
  -  Section View: *Three Quarter*
4.  Click the *Run* button.  
Since you deleted *Turn Setup2* and the Face Feature, material is left on the locating face. This could be machined using another setup.
  5.  Click the *Close* button to exit the simulation mode.
  6. Using ‘drag and drop’ feature, reorder the operations to cut the part in the order you think is most efficient.
  7. Click on the *File* menu and select *Save As* to save the part using an appropriate file name.

### Step 9: Post Processing Toolpaths

Post process the toolpaths in the same manner as explained in [Step 8 of the previous tutorial](#) (Tutorial 3) of this chapter.

## Turn 5

### Topics covered in this tutorial:

- [Adding an ID Groove Feature](#)
- [Adding OD Thread and ID Thread Features](#)
- [Displaying the Chuck](#)
- [Defining the Chuck](#)
- [Defining the Chuck Clamping Location](#)
- [Viewing the Chuck in Toolpath Simulation](#)



### Step 1: Opening the Part and Defining the Machine and Stock

#### Open the Part

1. Open part file **TURN2AX\_5.SLDPRT** in the following folder.

*C:\Users\Public\Public Documents\SOLIDWORKS\SOLIDWORKS 201x\CAM Examples\Tutorial\_Parts\Turn*

#### Define the Machine Parameters

1.  Click the *SOLIDWORKS CAM Feature Tree* tab.
2. Under this tree, observe that *Machine [Mill- inch]*  is the active machine. In this tutorial, the part will be machined on a Single Turret Turn machine.
3. Double-click on the Machine item.

OR

1.  Click on the *Define Machine* button on the SOLIDWORKS CAM Command Manager.

The *Machine* dialog box will be displayed.

- In the *Machine* tab of this dialog box, highlight *Turn Single Turret- inch* in the list of *Available machines* and click the *Select* button. (Executing this command replaces the currently active Mill machine listed in the Feature tree with this selected Turn machine when you close this dialog box by clicking on the *OK* button.)
- Click the *Tool Crib* tab, ensure *Tool Crib 2 Rear (Inch)* is the active tool crib.
- Click the *Post Processor* tab and make sure *T2AXIS-TUTORIAL* is selected.
- Click *OK* to apply the changes and exit the *Machine* dialog box.

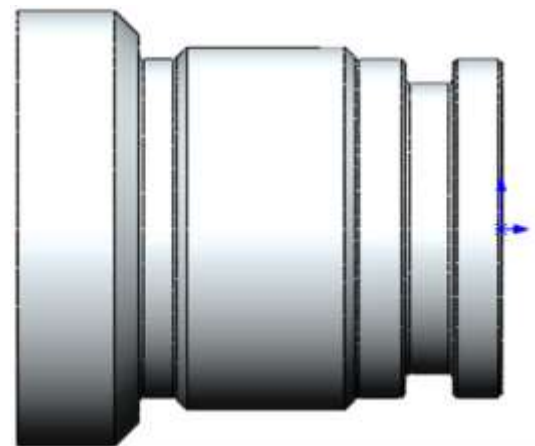

**TURN2AX\_5.SLDPRT**

## Defining the Stock

- Double click on *Stock Manager* item in the Feature tree.  
 OR  
 Click the *Stock Manager* button in the SOLIDWORKS CAM Command Manager.
- The Stock Manager dialog box is displayed. In this dialog box,
  - Leave the Stock Type set to *Bar stock*.
  - Change the Stock Length to **2.05in**
  - Click the down arrow to the right of the *Material* list and select the desired material from the dropdown list or use the default material.
  - Click *OK* to apply the changes and close the dialog box.



**Stock Manager Dialog box**

## Step 2: Extract Machinable Features

Click the *Extract Machinable Features* button on the SOLIDWORKS CAM Command Manager.

AFR analyzes the model for features to machine. When AFR is completed, the tree displays *Turn Setup1*, which establishes the workplane for turning, and the machinable features that were recognized.

When AFR is run on some parts, SOLIDWORKS CAM may not recognize all the features you want to machine or AFR may recognize a feature that might not be suitable for the intended machining process. When this occurs, you can delete unwanted features and define required features interactively.

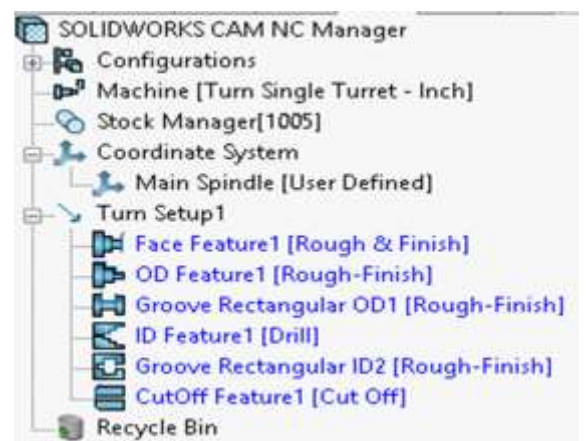

**Features Recognized using EMF**

## Deleting Features

1. Right click the *Groove Rectangular ID2* feature and select *Delete* on the context menu.  
For learning purposes, in this tutorial, you will delete the *Groove Rectangular ID2* feature and insert it interactively.
2. Since you will be defining a chuck for this part, also delete *Cutoff Feature1*.  
The deleted features will be moved to the *Recycle Bin*.
3. Click the  sign to the left of the *Recycle Bin* in the Feature tree to collapse it.

## Step 3: Adding an ID Groove Feature Interactively

In this tutorial, you are going to add three features interactively. The first feature will be the groove that you deleted in the previous step.

SOLIDWORKS CAM understands the shape of a groove and knows how it is to be machined. When you insert a Groove feature for this undercut area, SOLIDWORKS CAM knows how to machine the area using the standard Rectangular Groove machining techniques.



**Within SOLIDWORKS CAM, the typical groove configuration is defined as a rectangular shape consisting of two equal length walls, which may or may not have fillet radii and may or may not have corner breaks.**

### Steps to interactively insert an ID Groove Feature:

1. Right click *Turn Setup1* in the Feature tree and select *Set View>>Turn ZX* from the context menu.
2. The new feature will be inserted after the feature *ID Feature1*. Right click on *ID Feature1* and select *Turn Feature* from the context menu.

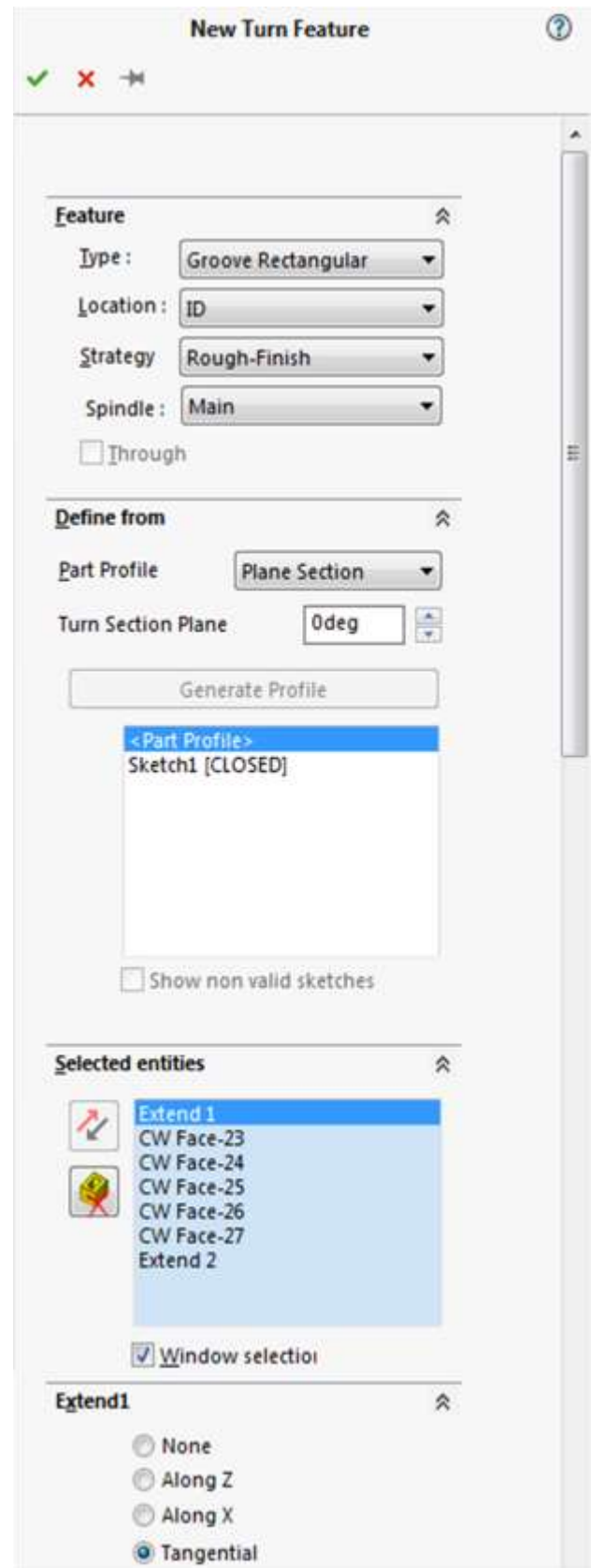

**New Turn Feature Dialog box**

The New *Turn feature* dialog box will be displayed.

3. In the *Feature* group box:
  - Select *Groove Rectangular* for Feature Type
  - Set the Location to *ID*.
  - Leave the Strategy set to *Rough-Finish*.
4. In the *Selected Entities* list box, make sure that the *Window selection* check box is checked.
5. In the graphics area, use the mouse to select the geometry for the groove by drawing a window around the groove entities as shown in the below figure.

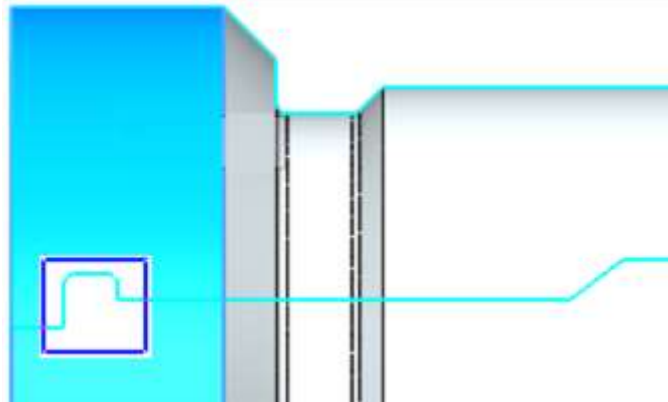

**Window Select the Rectangular ID Groove Feature**

The *Selected entities* list box will be updated to contain 5 selected face entities and 2 extent entities.

6. Highlight *Extend2* in the *Selected entities* list box.
  - The *Extend1* and *Extend2* group boxes will be expanded.
  - In the *Extend1* group box, set the direction to *Tangential*.
  - In the *Extend2* group box, set the direction to *Tangential*.

The extents will be displayed on the model part in the graphics area.

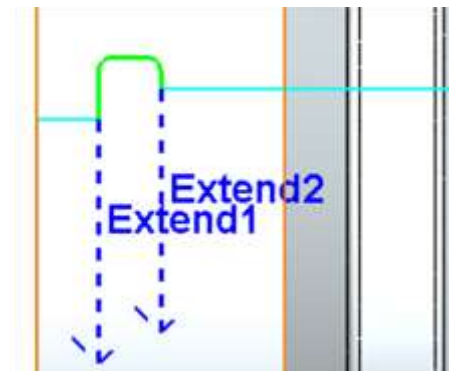

**Setting the direction of the Extent entities**

7.  Click *OK* to insert the feature.

*Groove Rectangular ID3* is added to the Feature tree.

## Step 4: Adding OD Thread and ID Thread Features Interactively

Thread information comes in many different formats and has many parameters. For a CAD/CAM system, it is not practical to model threads on a solid. Even though this can be

done, it is very difficult for software to interpret a helical cut in the OD of a part and decipher what type of thread it is.



**In SOLIDWORKS CAM, you can assign a Strategy to define a thread on a feature.**

In this tutorial, you will define OD and ID features to be threaded.

### Interactively Inserting a Threaded OD Feature

1. In the Feature tree, right click *OD Feature1* and select *Turn feature* on the context menu.  
The *Turn Feature* dialog box will be displayed.
2. In the *Feature* group box:
  - Leave the Feature Type set to *OD Feature*.
  - Set the Strategy to *Thread*.
3. In the graphics area, use the mouse button to pick the OD segment where the thread will be machined (indicated by arrow in the below figure).

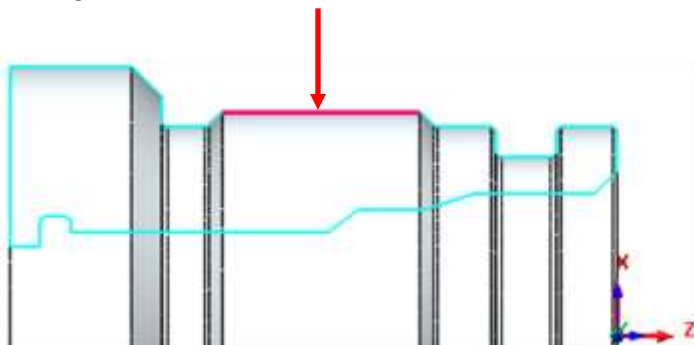

**Pick the OD segment to be threaded**

The *Selected entities* list box will be updated to contain 1 selected face entity and two Extend entities.

4. In the *Selected entities* list box, highlight *Extend 1* and *Extend 2*. Make sure *None* is selected in the corresponding *Extend* group boxes.

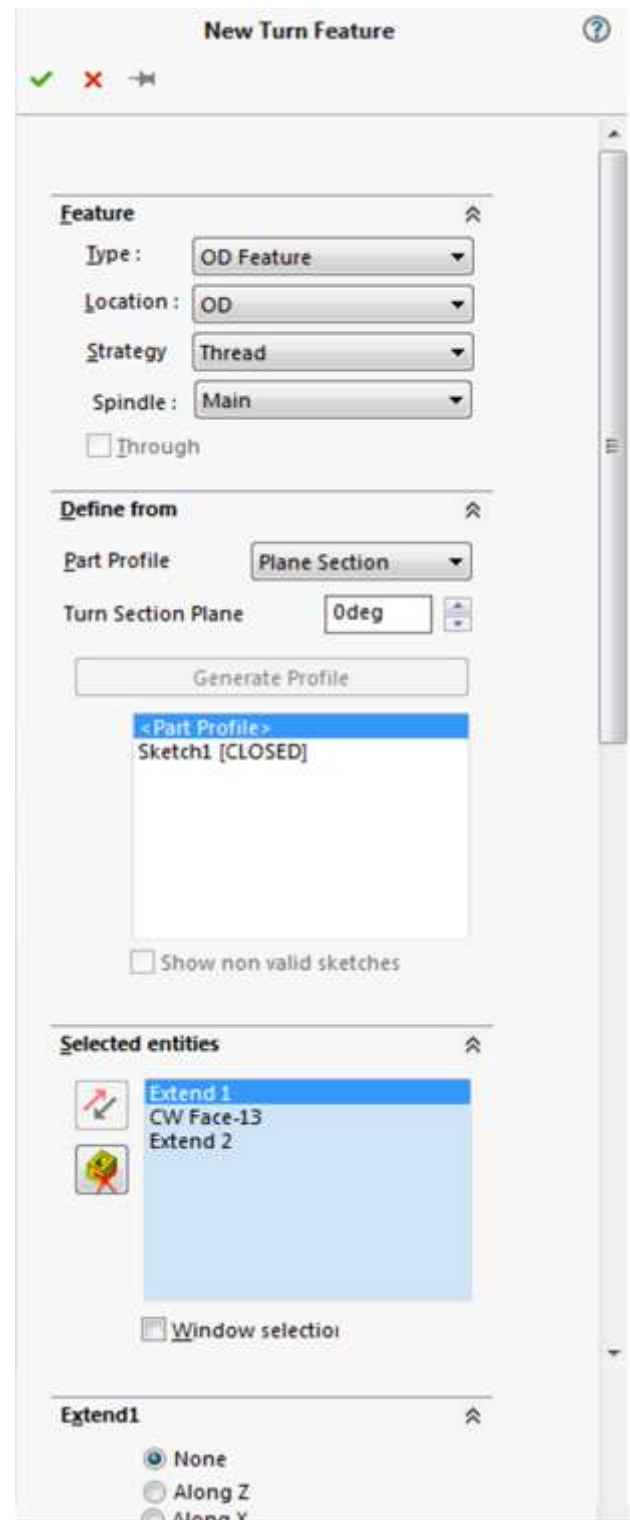

**New Turn Feature Dialog box**



If SOLIDWORKS CAM is calculating the WIP (work in process), ID and OD Thread features should not be extended in either Z or X. If you extent Thread features, SOLIDWORKS CAM determines the feature length relative to the WIP and may extent the feature to start threading closer to the face than you want. Typically, this would occur on thread features such as this one where the feature is not located at the face of the part.

To adjust the machining length for a Thread feature, you can:

- Specify a Start length in the Thread operation machining parameters.
- Set up the TechDB to define an amount that you want the tool to go beyond the thread length into a thread relief area.

5. Click *OK* to insert the feature. *OD Feature2* is listed in the Feature tree after *OD Feature1*.
6. Right click on *OD Feature2* and select *Parameters* on the context menu. The *OD Profile Parameters* dialog box is displayed.

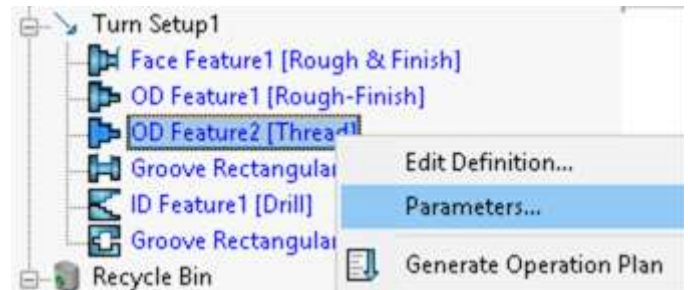

Context menu to open Parameters dialog box

Observe that the *Maximum dia. (D1)* for this feature is **1.5in**

7. Observe that the *Maximum dia. (D1)* for this feature is **1.5in**



In order to generate a Thread operation, the corresponding thread condition must be selected from the TechDB. The major diameter in the TechDB must match the feature maximum diameter.

Initially, the Thread Parameters display the values in the first record in the TechDB; however, this record has not been selected.

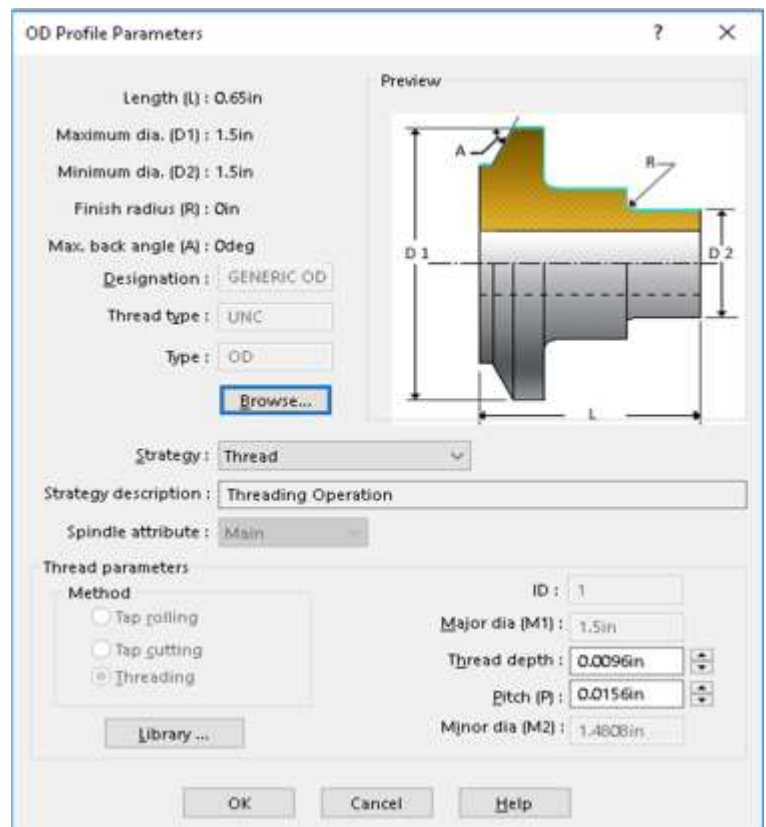

OD Profile Parameters dialog box



8. Click the *Library* button.  
The *Tools Database - Thread Condition* form is displayed.



Several thread conditions have been set up in the TechDB. When you machine your own parts, you can add data for additional threads.

9. In this form:
  - Select tool with **ID** of '43'.
  - Click *OK* to assign the selected Thread Condition.
10. Click *OK* to close the *OD Profile Parameters* dialog box.

	ID	Type	Designation	Pitch	EndPitch	DepthOfThread	ProcessMethod	Units	Spin
5	11	UNC	8-32 UNC	0.031200	0.000000	0.019200	1	2	1
6	13	UNC	10-24 UNC	0.041600	0.000000	0.025600	1	2	1
7	15	UNC	12-24 UNC	0.041600	0.000000	0.025600	1	2	1
8	17	UNC	1/4-20 UNC	0.050000	0.000000	0.030700	1	2	1
9	19	UNC	5/16-18 UNC	0.055600	0.000000	0.034100	1	2	1
10	21	UNC	3/8-16 UNC	0.062500	0.000000	0.038400	1	2	1
11	23	UNC	7/16-14 UNC	0.071400	0.000000	0.043800	1	2	1
12	25	UNC	1/2-13 UNC	0.076900	0.000000	0.047200	1	2	1
13	27	UNC	9/16-12 UNC	0.083300	0.000000	0.051100	1	2	1
14	29	UNC	5/8-11 UNC	0.090900	0.000000	0.055900	1	2	1
15	31	UNC	3/4-10 UNC	0.100000	0.000000	0.061400	1	2	1
16	33	UNC	7/8-9 UNC	0.111100	0.000000	0.068200	1	2	1
17	35	UNC	1-8 UNC	0.125000	0.000000	0.076700	1	2	1
18	37	UNC	1 1/8-7 UNC	0.142800	0.000000	0.087700	1	2	1
19	39	UNC	1 1/4-7 UNC	0.142800	0.000000	0.087700	1	2	1
20	41	UNC	1 3/8-6 UNC	0.166700	0.000000	0.102300	1	2	1
21	43	UNC	1 1/2-6 UNC	0.166700	0.000000	0.102300	1	2	1
22	45	UNC	1 3/4-5 UNC	0.200000	0.000000	0.122700	1	2	1

**Tools Database - Thread Condition form**

### ***Interactively Inserting a Threaded ID Feature***

1. Right click *ID Feature1* in the Feature tree and select *Turn feature* from the context menu.  
The Turn Feature dialog box will be displayed.
2. In the *Feature* group box:
  - Set the Feature Type set to *ID Feature*.
  - Set the Strategy to *Thread*.
3. In the graphics area, use the mouse button to pick the ID segment at the front of the part where the thread will be machined (indicated by the arrow in the figure).

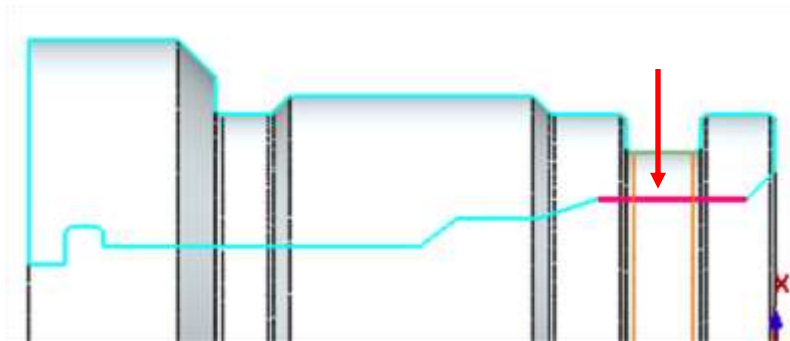

Pick the ID segment to be threaded

The *Selected entities* list box will be updated to contain 1 selected face entity and 2 extend entities.

4. In the *Selected entities* list box, highlight *Extend 1* and *Extend 2*. Make sure *None* is selected in the corresponding Extent group box.
5.  Click *OK* to insert the feature.

*ID Feature2* is added to the Feature tree after *ID Feature1*.

6. Right click on *ID Feature2* and select *Parameters* from the context menu.

The *ID Profile Parameters* dialog box is displayed. You need to select the thread condition for *ID Feature2*.

7. Observe that the *Maximum dia. (D1)* for this feature is **0.95in**.
8. Click the *Library* button in this dialog box.

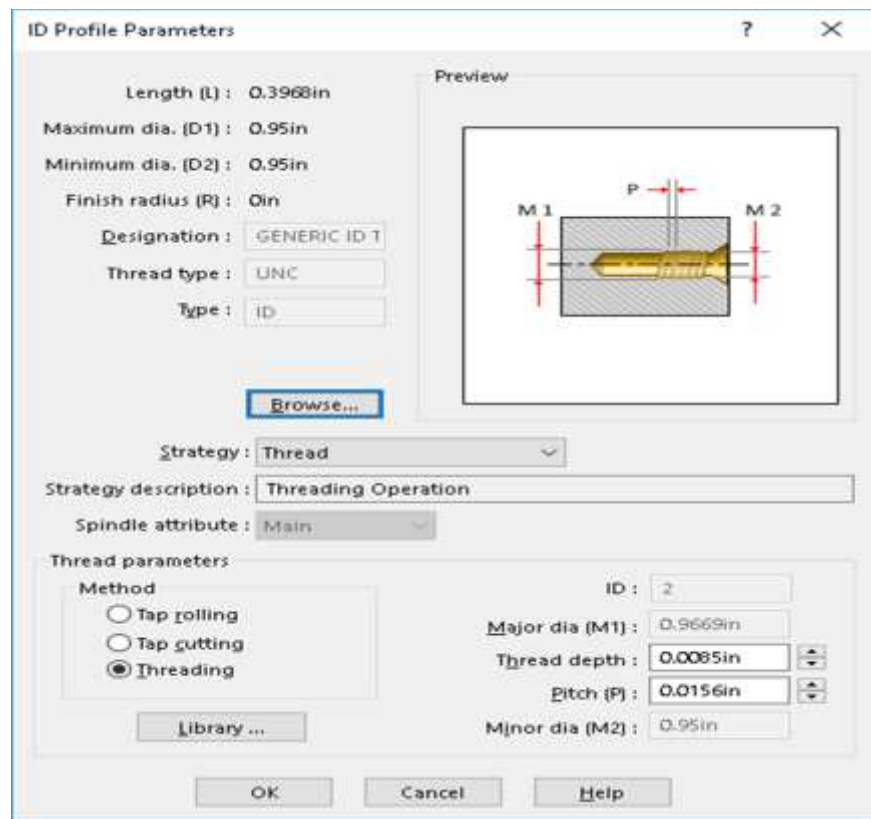

ID Profile Parameters dialog box

The *Tools Database Thread Condition* form is displayed.

9. In this form:

- A tool with **0.96 Major Dia.** is not available.
- Hence, select tool with **ID of '32'**.
- Click *OK* to assign the selected Thread Condition.

10. Click *OK* to close the *ID Profile Parameters* dialog box.

## Step 5: Changing Feature Parameters, Generating Operations and Modifying Operation Parameters

### Changing Feature Parameters and Renaming Features

Before generating operations, you can change feature parameters and rename features so that they are more descriptive.

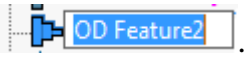
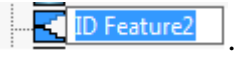
1. Right click *ID Feature1* in the Feature tree and select *Parameters* from the context menu.  
The *ID Profile Parameters* dialog box is displayed.
  - Change the Strategy to *Rough-Finish*.
  - Click *OK* to close the ID Profile Parameter dialog box.
2. Right click *OD Feature2* in the Feature tree and select *Rename* from the context menu.
  - A text box displays around the item. 
  - Type **OD Thread** and press *Enter* key.
3. Right click *ID Feature2* and select *Rename* from the context menu.
  - A text box displays around the item. 
  - Type **ID Thread** and press *Enter* key.

### Generating Operations

 Click the *Generate Operation Plan* button on the SOLIDWORKS CAM Command Manager.

OR

Right click *Turn Setup1* in the tree and select *Generate Operation Plan* from the context menu.

The Operations for all the features are generated and listed in the Operation tree.

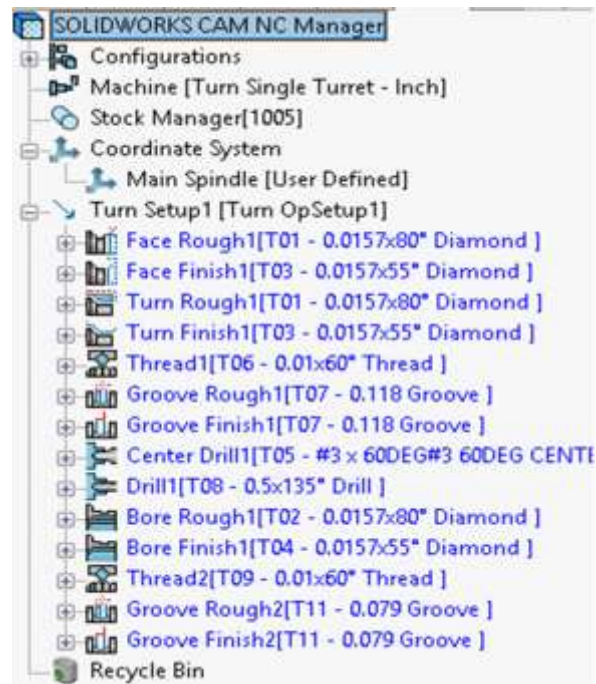

Operations listed in Operation tree

## Modifying Operation Parameters



You can modify operation parameters before or after generating toolpaths. Choosing parameters for machining depends on your machining practices.

The following examples show you how to make changes.

1. Double click *Thread1* in the Operation tree. The *Operation Parameters* dialog box is displayed.
2. Click on the *Thread* tab. Change the following values in the *Parameters* group box:

- Depth per cut = **0.03in**
- Final cut amount = **0.009in**
- Start length = **0.15in**

The start length is measured from the start of the OD Thread feature that you created and is a distance in front or to the right of the feature.

Since this is an OD feature and the tool is on a rear turret, the tool orientation is down and left. (Click on the *Holder* page of the *Tool* tab to view the *Tool Orientation*.)

- Pitch = **0.065in**
  - Click *OK* to close the dialog box.
3. Double click *Groove Rough1* in the tree. The *Operation Parameters* dialog box is displayed.
  4. Click on the *Groove Rough* tab.
    - In the *Allowance* group box, change the Radial (X) and Axial (Z) allowances to **0.0in**.
    - Click *OK* to close the dialog box.
  5. Right click *Groove Finish1* in the Operation tree and select *Delete* from the context menu. Click *Yes* to confirm the deletion.
 

By setting the Groove Rough allowances to **0.0in**, you can rough and finish the groove in one operation. Hence, this Groove Finish operation was deleted.
  6. Double click *Groove Rough2* in the Operation tree. The *Operation Parameters* dialog box is displayed.
  7. Click on the *Groove Rough* tab.

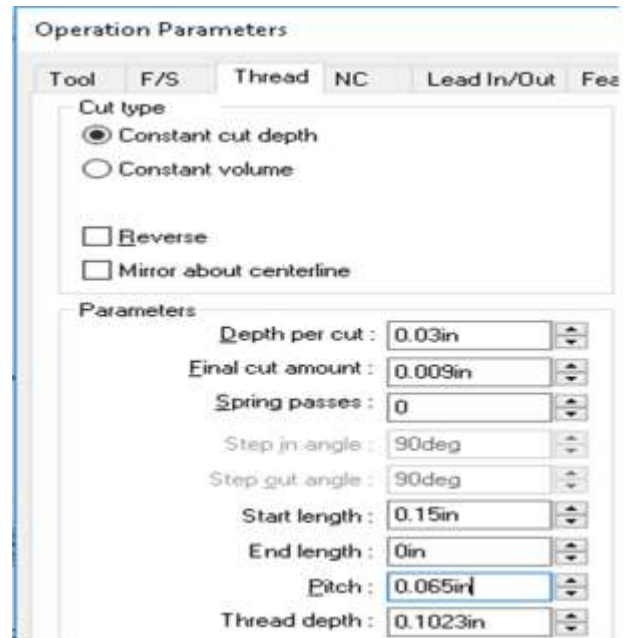

**Modifying Thread Parameters**

- In the *Allowance* group box, change the Radial (X) and Axial (Z) allowances to **0.0in**.
- Click on the *Tool* tab. Select the *Boring Bar* page. In the graphics area, observe that the width of the Groove Insert used to machine this feature is lesser than the width of the feature. Hence, toolpaths will be generated correctly for this Groove feature.

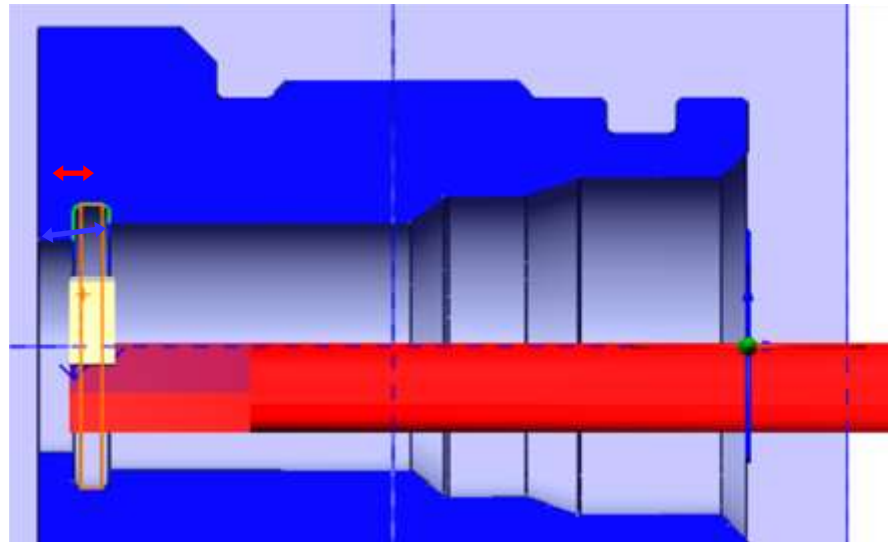

**Width of the Groove Insert is greater than the width of the feature**



In cases where the width of the Groove Insert used to machine the feature is greater than the width of the feature, toolpaths will not be generated. You will have to either assign suitable Groove insert from the active Tool Crib or add a Groove Insert Tool from the Tool Library to the active Tool Crib and assign it to the operation.

8. Right click *Groove Finish2* and select *Delete* from the context menu. Click *Yes* to confirm the deletion.

## Step 6: Defining the Machining Sequence and Generating Toolpaths

The order that the operations are listed is relative to the feature order. Both the Feature tree and the Operation tree can be reordered to achieve the specific machining sequences that are needed in terms of tool order and material removal.

1. In the Operation tree, drag *Groove Rough2* above *Bore Finish1*.

2.  Click the *Generate Toolpath* button on the SOLIDWORKS CAM Command Manager.

OR

Right click on *Turn Setup1* in the Operation tree and select *Generate Toolpath* from the context menu.

3. Click on each operation to view the toolpath.

## Step 7: Displaying the Chuck/Fixture

You can choose to display/not display the chuck in which the part will be clamped.

1. In the Operation tree, right click on the *Machine [Turn Single Turret -inch]* and select *Chuck Display*.

An expandable cascading menu displays the various display options on how the chuck will be displayed in the Graphics area.

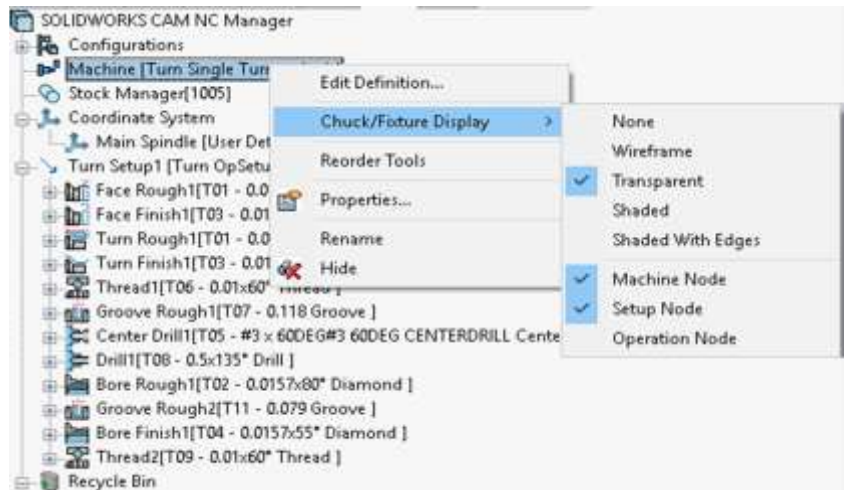

**Chuck Display Options**

- **Non-display:** When set to *None*, the chuck will not be displayed in the Graphics area. Instead, two locating triangles will be displayed. These triangles provide a graphical representation of where the part will be clamped in the chuck.
  - **Chuck Display States:** When the other display option *Wireframe*, *Transparent*, *Shaded* or *Shaded with Edges* is chosen, the chuck will be displayed accordingly in the graphics area.
  - **Node Display:** You can select the Operation tree item, which on being selected/highlighted in the Operation tree, will display the Chuck in the selected display option state. You can select one or more among the options of *Machine node*, *Setup node* and *Operation node*.
2. In the *Chuck/Fixture Display* cascading menu:
    - Select *Transparent* for Chuck/Fixture Display state.
    - Select *Machine Node* and *Setup node* by clicking on these options. A checkmark next to these options indicates that they have been selected.
    - Ensure *Operation node* is not selected.
  3. In the Operation tree, left click on *Turn Setup1*. Observe that the Chuck is displayed in the graphics area.
  4. Next, left click on the *Machine [Turn Single Turret - inch]*. The chuck is once again displayed in the graphics area.
  5. Left click on the different operations. Observe that the chuck is not displayed. This is because the *Operation Node* display option was not selected in the *Chuck Display* menu.

## Step 8: Defining the Chuck/Fixture

1. Double click the *Machine [Turn Single Turret - inch]* in the Operation tree.

OR

1. Click on the *Define Machine* button in the SOLIDWORKS CAM Command Manager.

The *Machine* Dialog box is displayed.

2. Click on the *Chuck/Fixture* tab.



The *Chuck/Fixture* tab allows you to define the **Chuck geometry (size of the chuck base and the jaws)** to be displayed in the graphics area and during toolpath simulation.

3. The *Chuck/Fixture* tab displays the *Main Spindle Information*.

4. In the *Main Spindle Information* group box, the *Name* field indicates the name of the current Chuck Configuration. By default, the Chuck Configuration *6in\_2Step\_Chuck* is displayed.



A **Chuck Configuration** is a set of chuck parameter values defined and saved in the TechDB. SOLIDWORKS CAM allows multiple configurations of chuck parameters to be saved in the TechDB and reused. You must select/create/edit a chuck configuration as per your requirements for the turn part. A ready set of commonly used chuck configurations are already available within SOLIDWORKS CAM.

In the *Main Spindle Information* group box, click on the *Edit* button. The *Chuck Parameter: [Main Spindle]* dialog box is displayed.

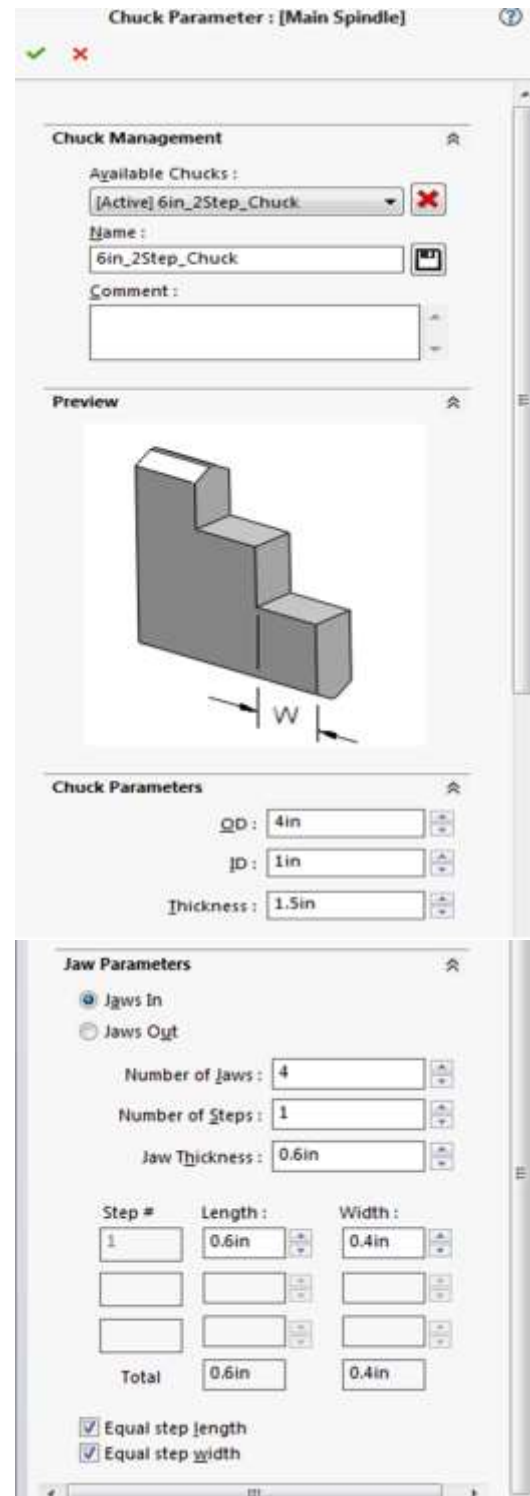

**Chuck Parameter dialog box**



**Use the Chuck Parameter dialog box to edit existing chuck configurations and to define additional chuck configurations.**

This dialog box allows you to define the size of the chuck base and the jaws.

5. In the Chuck Parameters group box, assign the following values:

- OD = **4in**
- ID = **1in**
- Thickness = **1.5in**

The *Preview* area of the dialog box provides a graphical description of the active Chuck Parameter.

Observe that as soon as you shift focus from the active Chuck parameter, the graphical representation of the chuck is immediately updated in the graphics area to match the new values you have entered.

6. In the Jaw Parameters group box, assign the following values:

- Number of Jaws= **4**
- Number of Steps = **1**
- Jaw Thickness = **0.6in**
- Step Length = **0.6in**
- Step Width = **0.4in**



**The Jaw Thickness value should be less than or equal to the Step Length else SOLIDWORKS CAM will not display the chuck and will display an error message indicating that the Jaw Chamfer is larger than the Step Length.**

The *Equal step length* and *Equal Step width* options apply only when there are multiple steps.

7. The changes you have made to the active chuck configuration can either be saved to the TechDB or applied only for the current part.

-  If you directly click *OK* after making the changes, then the changes made to the chuck configuration will be applicable only to the current part. For all other machining jobs, the original set of values will be applied.
- **Overwriting existing Chuck Configuration:**

In the *Chuck Management* group box, the name of the active chuck configuration is displayed in the name field. If you click



**SOLIDWORKS CAM Warning message displayed when you try to save an edited Chuck Configuration**



on the *Save* button  next to this field after making the changes, SOLIDWORKS CAM will display a warning message indicating that a chuck configuration by that name already exists.

If you click *Yes* within the message, then the active chuck configuration will be replaced with the new set of values and saved to the TechDB. The new set of values will be available for all future jobs.

- If you click *No* within the message, SOLIDWORKS CAM will return to the Chuck Parameter dialog box.

#### - Defining a new Chuck Configuration:

If you want the changes made saved as a new chuck configuration which will be available for future jobs, enter a new name in the *Name* field in the *Chuck*

*Management* group box. After making the changes, click on the *Save* button . This new chuck configuration will be available in the *Available Chucks* drop down list.

8. In this tutorial, you will not save the edited configuration. Click the *Cancel* button  to exit the *Chuck Parameter: [Main Spindle]* dialog box.
9. Click *OK* to close the *Machine* dialog box.

## Step 9: Defining the Chuck Location

1. Double click *Turn Setup1* in the Operation tree.  
The *Operation Setup Parameters* dialog box is displayed.
2. In the *Origin* tab, ensure that *Spindle Origin* is selected.  
This is where the Origin or Part Zero is located.
3. Click the *Chuck/Fixture Location* tab.

The WIP Sketch/Stock Boundary is displayed on the part in the graphics area. Two locating triangles display at Part Zero by default.

Use the parameters in the *Clamping Location* group box of the *Chuck Location* tab to position these two triangles in order to reflect where the chuck will be located.

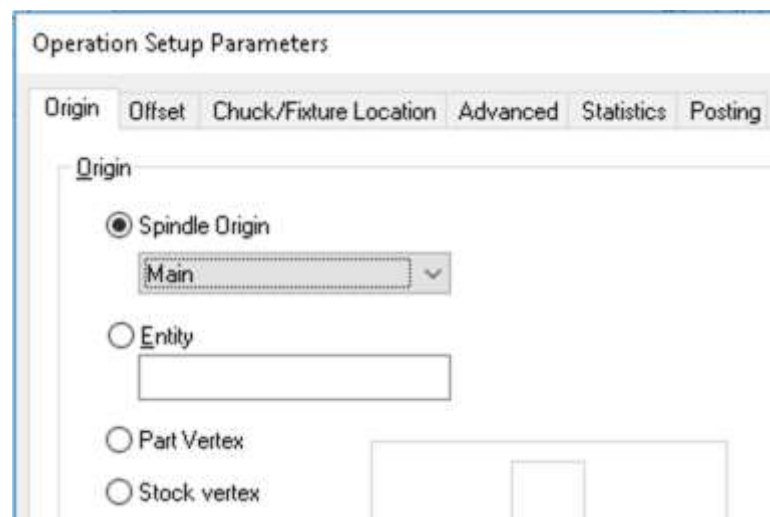

**Operation Setup Parameters Dialog Box**



For a Main Spindle Turn setup, the Clamping Location (represented by the locating triangles) is located at the most negative Z end point of the WIP sketch/Stock Boundary.

- Use the *Select Entity for Z Clamping Location* field in the Clamping Location group box to select the entity to clamp along Z.

-  Click on *Select Entity for Z Clamping Location* field to set the focus.
- In the graphics area, pick any circular edge of the part whose normal is parallel to the turn axis and center is concentric with turn axis. The Clamping Location changes.
- Now click on the left-most vertical edge of the stock WIP sketch. The Clamping Location moves back to its original location.

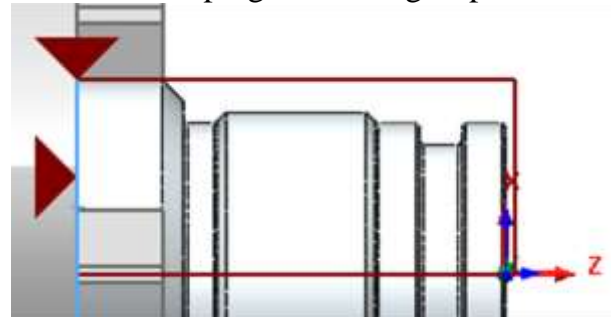

Selecting a Circular edge

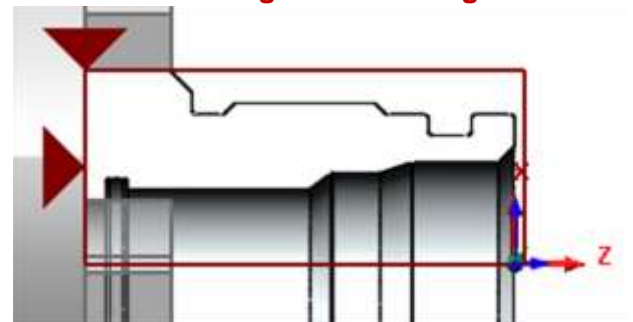

Selecting a Left-most vertical WIP entity



An entity fulfilling any one of the following criteria can be selected as a Z Clamping location:

- Circular edge whose normal is parallel to the turn axis and center is concentric with turn axis
- Vertical WIP entity

- You can also change the size of the triangles. Use the *Triangle display* group box in the *Chuck/Fixture Location* tab to change the size. Change the size to **0.2in**.
- Observe the *Chuck Properties* group box in the *Chuck/Fixture Location* tab. You can define the chuck from the *Machine* level or *Setup* level.
  - Defining the chuck from Setup may be preferred when machining a part with multiple turn setups where the chuck may change from setup to setup.
- Click *OK* to close the dialog box.













A graphic of the part can be added to the setup sheet to give the shop floor a better understanding of the setup.



#### Did You Know ...

If you change the Chuck Configuration, you will need to position the locating triangles again using the *Chuck/Fixture Location* tab of the *Operation Parameters* dialog box.

## Step 10: Simulate Toolpath

1. Change the *View Orientation*  to *Isometric*  .
2. Right click *Turn Setup1* in the Operation tree and select *Simulate Toolpath* from the context menu.  
OR  
 Click on the *Simulate Toolpath* button on the SOLIDWORKS CAM Command Manager.  
The *Toolpath Simulation* toolbar is displayed.
3. Select the following display options:
  -  Fixture: *Shaded With Edges*
  -  Tool holder: *Shaded With Edges*
  -  Tool: *Shaded With Edges*
  -  Target part: *Translucent Display*
  -  Section view: *Half*
4.  Click on the *Run* button.  
Observe that the OD feature is threaded.
5.  Click *Close* to exit the simulation.
6. Double click on the *Machine [Turn Single Turret - inch]* in the Operation tree.
7. Click on the *Chuck* tab. Edit the Chuck Configuration and try different settings: change the number of steps and the size of the steps and the base, then click *OK*.
8.  Run the Toolpath Simulation again and view the changes.

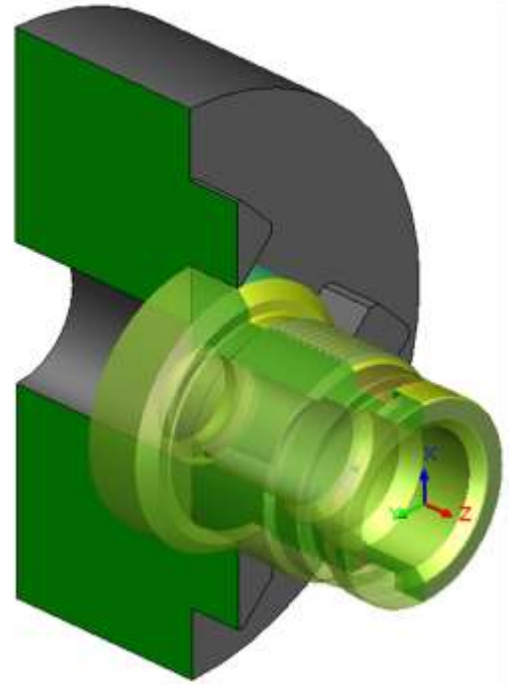

**Toolpath Simulation**

## Step 11: Post Processing Toolpaths

Post process the toolpaths in the same manner as explained in [Step 8 of the Tutorial 3](#) of this chapter.

## Turn 6

Double chucking is a method that allows the NC programmer to machine a Turn Stock on both sides of the part using the Main Spindle. Such double chucking operations are supported in SOLIDWORKS CAM turning.

The methodology for doing a double chucking operation using the Main spindle is explained in this tutorial.

### Topics covered in this tutorial:

- [Establishing Part Zero](#)
- [Defining a stock from a sketch for double chucking](#)
- [Changing Feature Definitions for OD & ID Profiles](#)
- [Changing the origin machining direction](#)
- [Defining the Chuck Configuration](#)
- [Setting the Chuck Display State](#)
- [Setting the chuck location](#)
- [Simulating toolpaths for double chucking](#)

### Step 1: Opening the Part

1. Open part file **TURN2AX\_6.SLDPRT** in the following folder.

*C:\Users\Public\Public Documents\SOLIDWORKS\SOLIDWORKS 201x\CAM Examples\Tutorial\_Parts\Turn*

In this tutorial, assume that *Side 1* and *Side 2* are established as shown on the right.

- *Side 1* will be machined first and you will be chucking on *Side 2*.
- Since the material is a solid billet, you will be locating on the billet OD on *Side 2*.

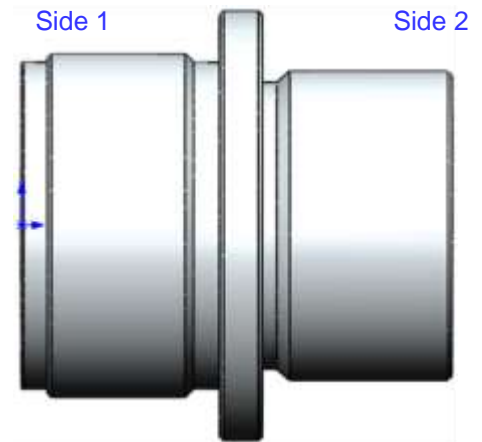

**TURN2AX\_6.SLDPRT**

### Step 2: Defining Machine Parameters

1. Click the *SOLIDWORKS CAM Feature Tree* tab.
2. Under this tree, observe that *Machine [Mill- inch]* is the active machine. In this tutorial, the part will be machined on a Single Turret Turn machine.

Double click the *Machine* item in the Feature tree. OR

 Click on the *Define Machine* button on the SOLIDWORKS CAM Command Manager.

The *Machine* dialog box is displayed.

- In the *Machine* tab of this dialog box, highlight *Turn Single Turret- inch* in the list of *Available machines* and click the *Select* button. (Executing this command replaces the currently active Mill machine listed in the Feature tree with this selected Turn machine when you close this dialog box by clicking on the *OK* button.)
  - Click the *Tool Crib* tab, ensure *Tool Crib 2 Rear (Inch)* is the active tool crib.
  - Click the *Post Processor* tab and make sure *T2AXIS-TUTORIAL* is selected.
3. Do not close the *Machine* dialog box.

### Step 3: Establishing Part Zero

Since this part is a cylinder, SOLIDWORKS CAM already knows where the centerline is. SOLIDWORKS CAM automatically sets the origin to a default setting and establishes a default centerline.

For a single chucking operation, the default origin may be acceptable. Since you are doing a double-chucking operation, however, you need change the default to set the system origin for *Side 1*.

1. Click the *Setup* tab in the *Machine* dialog box.
 

Observe the part in the graphics area. The origin X and Z symbol displays on the part in the default location (at the face of the part) for *Side 2*.
2. In the *Main spindle coordinate system* group box:
  - i. Click on the *Edit* button
  - ii. The *Main spindle coordinate system* dialog box will be displayed.
  - iii. Set the method to *SOLIDWorks Coordinate system* from the *Method* dropdown list.
  - iv. In the *Available coordinate systems* list box, select *Side1 Origin*.
  - v. This action selects the entity *Side 1 Origin*. The origin marker will moves to *Side 1*.
  - vi. Close this dialog box by clicking on the *OK* button.
3. Click *OK*  button in the *Machine* dialog box to apply the changes and close the dialog box.

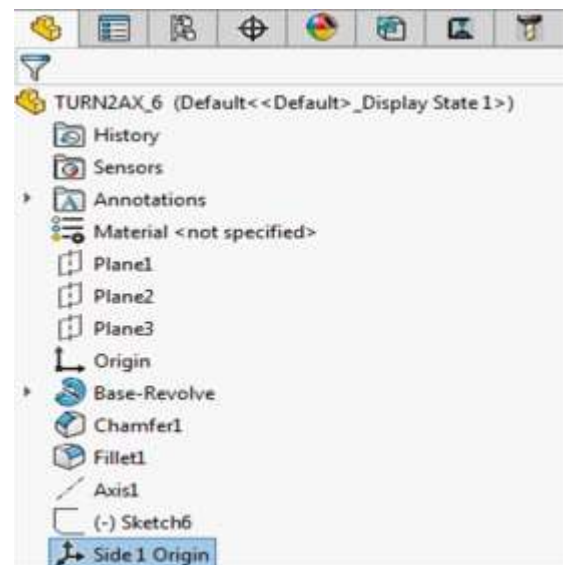

**Feature Manager Design Tree**

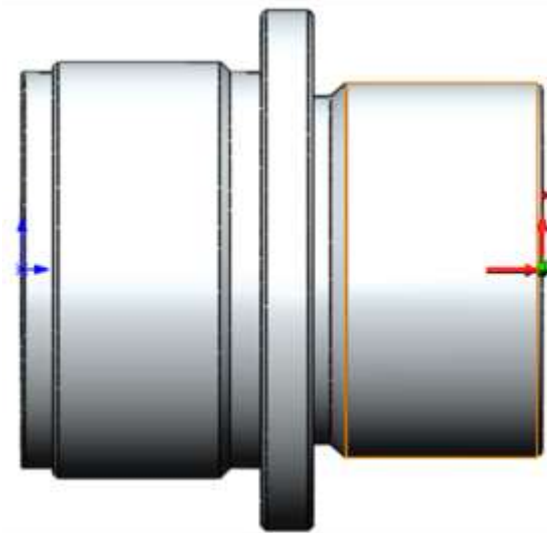

Default Origin at Side 2

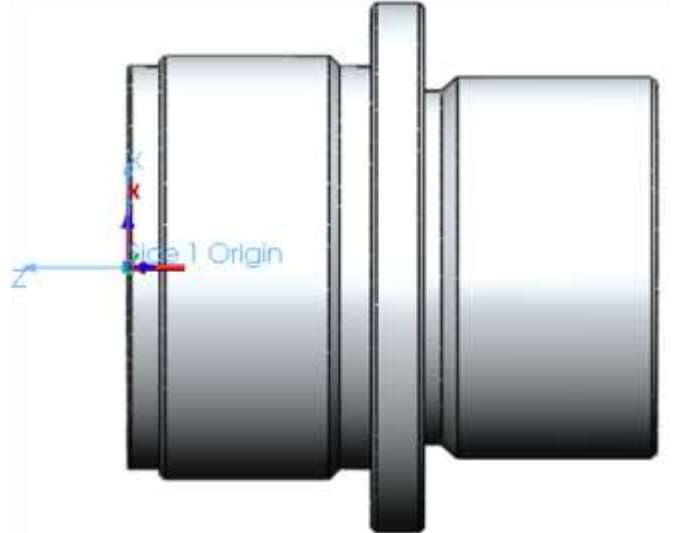

Origin changed to Side 1

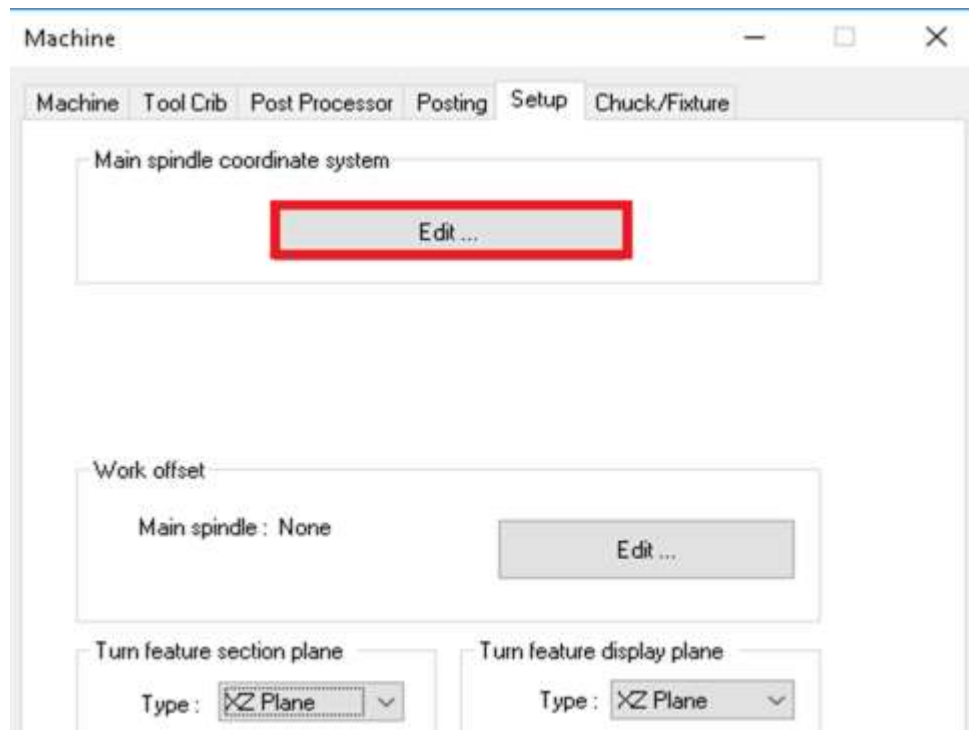

Setup tab of Machine dialog box

## Step 4: Defining the Stock from a Sketch for Double Chucking

The turn part model in this tutorial will be machined by double chucking. For double chucking, two Turn Part Setups will be required. To define two setups, a sketch (which is longer than the part on both the sides) must be used to define the stock.



**Always define the stock from a sketch when machining a turn part using double chucking. Defining a stock from a sketch establishes 2 distinct faces (or ends of the part) which is necessary for double chucking. Since bar stock has an infinite side length and one face, you cannot select Bar stock for double chucking.**

In this tutorial, you will define the stock from a sketch for the purpose of generating two setups for double chucking.

1. Click the *SOLIDWORKS CAM Feature Tree* tab.
2. Double click *Stock Manager* in the Feature tree.

OR



Click the *Stock Manager* button in the SOLIDWORKS CAM Command Manager.

In the displayed Stock Manager dialog box:

- Set the Stock Type to *From Revolved Sketch*.
- In the *Available sketches* list, select *Sketch6*.
- Click *OK* to apply the changes and close the dialog box.



**Stock Manager Dialog box**

## Step 5: Defining Machinable Features

Click the *Extract Machinable Features* button on the SOLIDWORKS CAM Command Manager.

OR

Right click *SOLIDWORKS CAM NC Manager* in the Feature tree and select *Extract Machinable Features* from the context menu.

On executing this command, two Turn Setups are created and AFR recognizes the features that can be machined in each Setup.

AFR has found an OD Feature and an ID Feature in *Setup 1* that each extent from the front face to the back face.

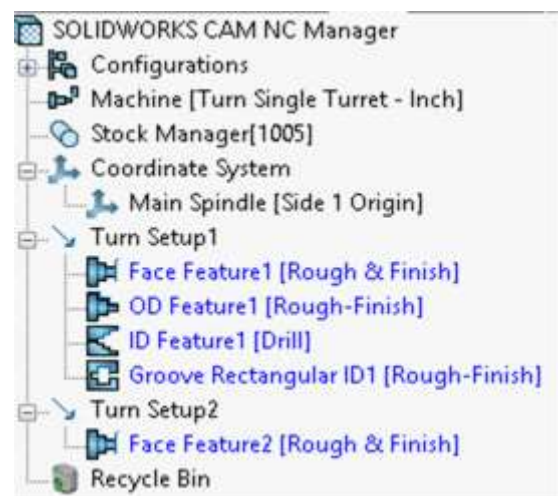

**Turn features recognized by EMF**

## Changing Feature Definitions for OD and ID Profiles

In this tutorial, you will edit the feature definitions in Setup 1 and create new features in Setup 2 such that half of the OD profile and ID profile is machined from *Setup1* while the other half of these profiles is machined from *Setup2*. The double-chucking environment makes this possible.

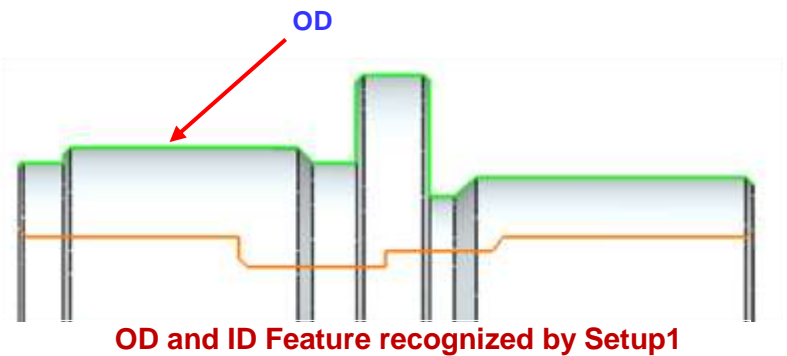

### Editing OD Feature in Turn Setup1:

1. Double click *OD Feature1* in the tree. The *Edit Turn Feature* dialog box will be displayed.
2. In this dialog box, in the *Selected Entities* list box, make sure the *Window selection* option is checked.
3. Window-pick the segments of the part as shown in the figure.

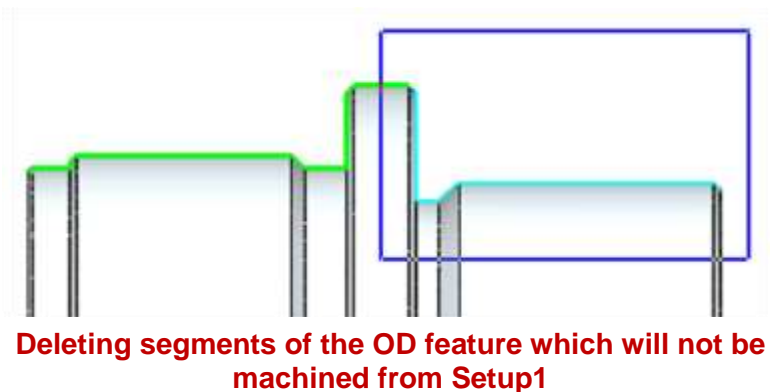

This action deletes all the segments (in blue highlights) captures by the window.

The *Selected entities* list will now display only those segments (in green highlights) which will be machined.

4.  Click *OK* to close the dialog box.

### Interactively Inserting OD Feature in Turn Setup2:

The next step would be to interactively insert the part of the OD feature the segments of which were deleted in the previous step) which will be machined from *Turn Setup2*.

1. Under *Turn Setup2*, right-click *Face Feature2* and select *Turn Feature* from the context menu.
 

The *New Turn Feature* dialog box will be displayed.
2. In this dialog box:
  - Select *OD Feature* as the *Feature Type*.
  - Select *Rough-Finish* as the *Strategy*.
  - In the *Selected Entities* list box, make sure the *Window selection* option is checked.



- Window-pick the same segments (faces) that you removed from *OD Feature1* as shown in the figure on the previous page.
3.  Click *OK* to insert the feature.  
*OD Feature2* is added to *Turn Setup2* after *Face Feature2*.

### Editing ID Feature in Turn Setup1:

1. Double click *ID Feature1* in the tree. The *Edit Turn Feature* dialog box is displayed.
2. Change the Strategy to *Rough-Finish*. This is necessary as the default strategy *Drill* only generates *Center Drill* and *Drill* operations while the *Rough-Finish* strategy, in addition to the *Drill* operation, also generates *Rough* and *Finish Boring* operations required to completely machine the feature
3. In this dialog box, in the *Selected Entities* list box, make sure the *Window selection* option is checked.
4. Window-pick the segments of the part as shown in the figure.  
The *Selected entities* list will now display only the segments (in green highlights) which will be machined from *Turn Setup1*.
5.  Click *OK* to close the dialog box.

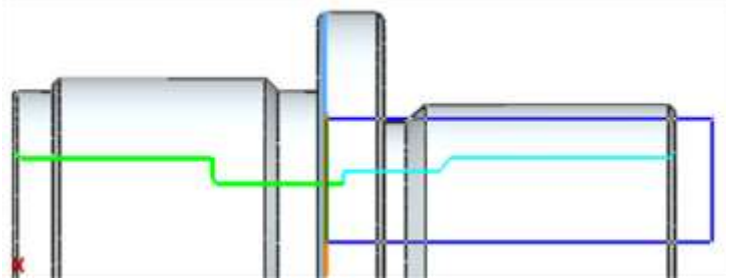

Deleting segments of the ID feature which will not be machined from Setup1

### Inserting ID Feature in Turn Setup2:

1. Right click *OD Feature2* in *Turn Setup2* and select *Turn Feature* from the context menu.  
The *Turn Feature* dialog box will be displayed.
2. In this dialog box:
  - Select *ID Feature* for the Feature Type.
  - Select *Rough-Finish* as the Strategy.
  - In the *Selected Entities* list box, make sure the *Window selection* option is checked.
  - Window-pick the same segments (faces) that you removed from *ID Feature1* as shown in the right side figure.
  - The selected segments should be *CW Face-25* through *29*. If any extra

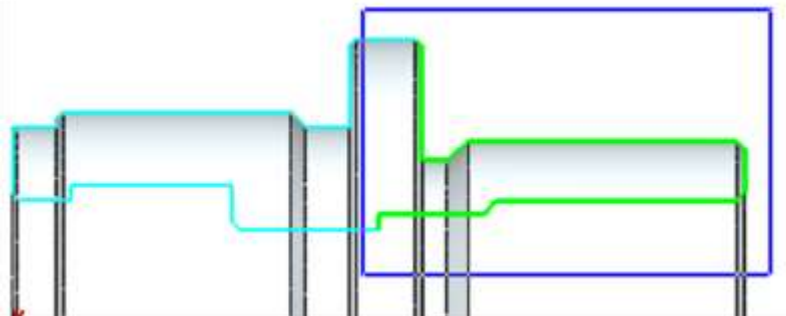

Inserting segments of the ID feature which will be machined from Setup2

face(s) are listed, highlight that face name in the *Selected Entities* list and press the *Delete* button.

- Click *OK* to insert the feature.

3. *ID Feature2* is added to *Turn Setup2*.

The OD and ID features in *Turn Setup2* should look like the features in the figure on the right.

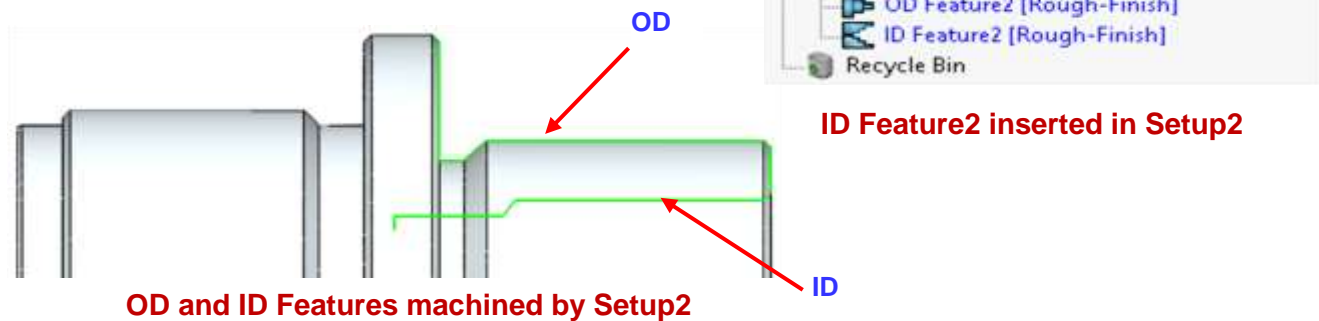

## Step 6: Changing the Origin Machining Direction

1. Left click each Turn Setup in the Feature tree and notice the Origin of the machining direction indicated by the **3D Origin marker** that displays on the part model.
2. The Origin is at the back of the part for both Turn Setups. For *Turn Setup1*, this is correct; however, the origin needs to be changed for *Turn Setup2*.
3. In the SOLIDWORKS CAM Operation tree, double click *Turn Setup2*.  
The *Operation Setup Parameters* dialog is displayed.
4. On the *Origin* tab, set *Part Vertex* as Origin. Select the vertex as shown below.
5. Click *OK* to close the dialog box.

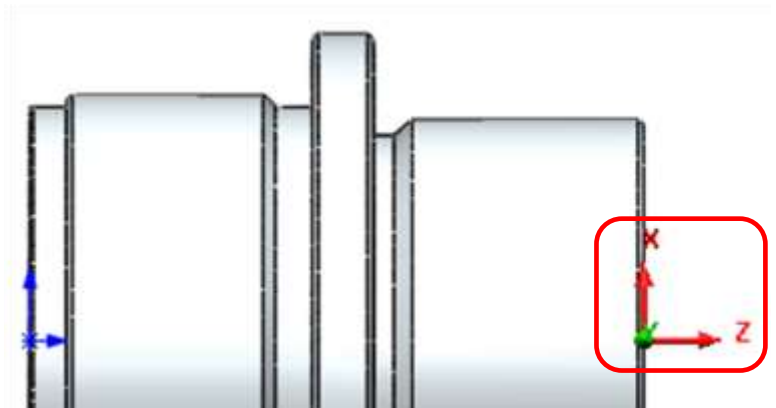

**3D Origin marker displayed on the part model**

In the graphics area, observe that the **3D Origin marker** for *Turn Setup2* has moved to the front face.

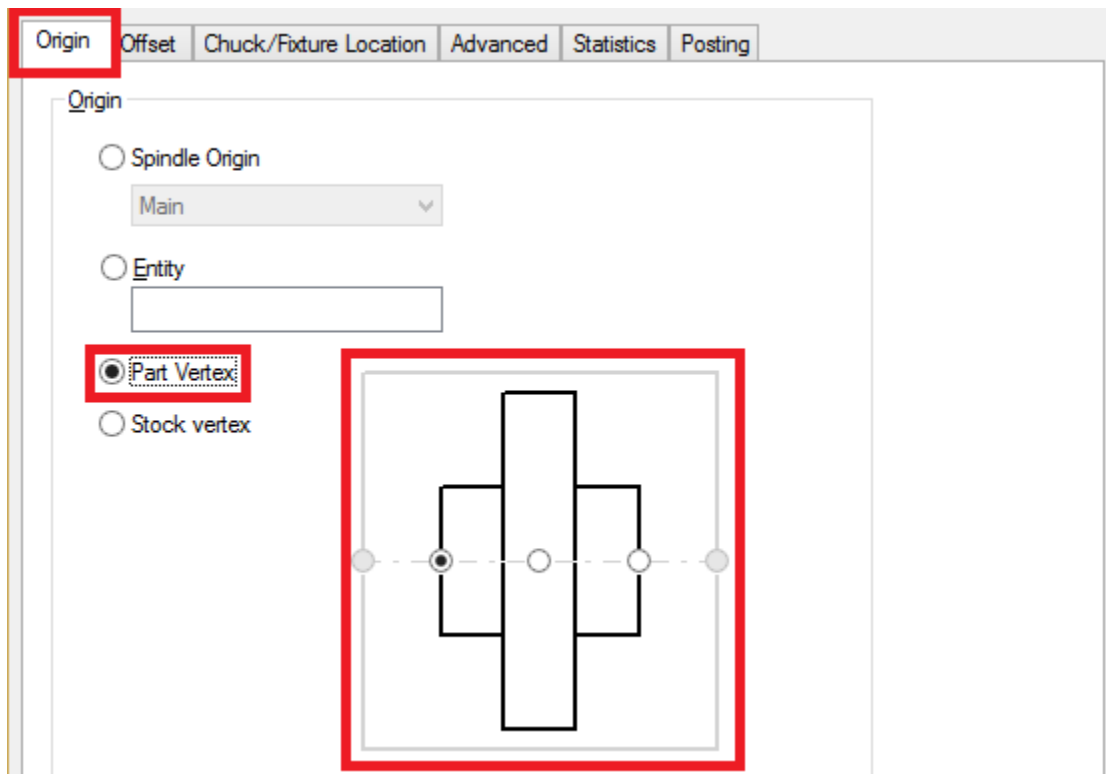

Selecting part Vertex to determine Origin in Origin tab of Operation Setup Parameters dialog box

## Step 7: Generating Operations and Editing Operation Parameters

1.  Click the *Generate Operation Plan* button on the SOLIDWORKS CAM Command Manager.

OR

Right click *SOLIDWORKS CAM NC Manager* in the Feature tree and select *Generate Operation Plan* from the context menu.

Operations are created for the machinable features in the Turn Setups and are listed in the Operation tree.

2. Double click *Drill1* (for *ID Feature1*) under *Turn Setup1* in the Operation tree. The *Operation Parameters* dialog will be displayed

3. On the Feature Options tab:
  -  Click on the *Override Machining Depth* button. Change the Machining length to **5.2in**. Increasing this length will drill the part all the way through.
  - Place a check in the *Add tip length* check box. With this option selected, SOLIDWORKS CAM takes into account the drill point angle when generating the toolpath.

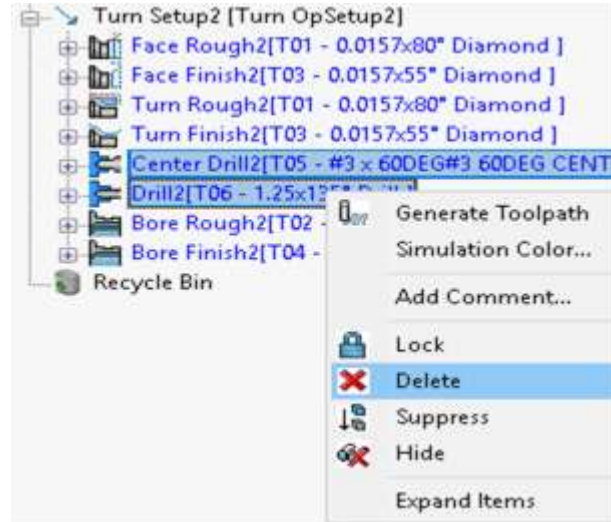

**Deleting Drill Operations in Turn Setup2**

4. Click *OK* to close the dialog box.
5. Under *Turn Setup2*, hold down the Shift key and select *Center Drill2* and *Drill2* operations in the tree.
6. Click on the *Delete* key.

Click *Yes* to confirm the deletion. As a result of the changes to the drill operations in *Turn Setup1*, you can delete these operations because there will no longer be stock on the face.



- Click the *Generate Toolpath* button on the SOLIDWORKS CAM Command Manager. Click each operation in the tree to view the toolpaths.



## Step 8: Defining the Chuck Configuration

You are now ready to define the chuck location for each Setup and run the Toolpath Simulation.

1. Double click the *Machine [Turn Single Turret - inch]* in the Operation tree. The *Machine* dialog box is displayed.
2. Click on the *Chuck/Fixture* tab.
  - In the *Main Spindle Information* group box, click on the *Edit* button. The *Chuck Parameter [Main Spindle]* dialog is displayed.

- In the Chuck Management group box, select *6in\_2Step\_Chuck* from the *Available Chucks* list.
  - In the *Jaw Parameters* group box, ensure that the *Length* and *Width* is set to **0.5in**.
  -  Click *OK* to apply the changes and close the dialog box.
3. Click *OK* to close the Machine dialog box.

### Step 9: Setting the Chuck Display State

1.  Right click the *Stock Manager* item in the Operations tree and select *Display>>Translucent* in the cascading menu.
2.  Right click on the *Machine [Turn Single Turret - inch]* item in the Operation tree and select *Chuck/Fixture Display>> Shaded with Edges* in the cascading menu.
3. Once again,  right click on the *Machine [Turn Single Turret - inch]* item in the Operation tree and this time, select *Chuck/Fixture Display>>Machine Node* from the cascading menu. The active selection is indicated by a check next the *Machine Node* label.

When the *Machine Node* option is selected, the chuck is displayed in the graphics area whenever the Machine item is selected in the Operation tree.

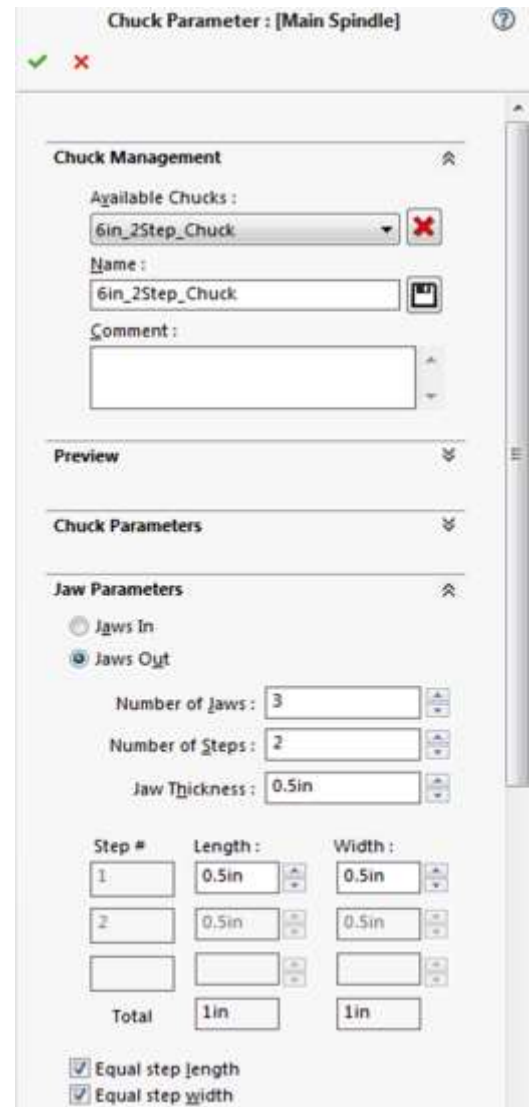

**Chuck Parameters Dialog box**

- Once again,  right click on the *Machine [Turn Single Turret - inch]* item in the Operation tree and this time, select *Chuck/Fixture Display>>Machine Node* from the cascading menu. The active selection is indicated by a check next the *Machine Node* label.

- Once again,  right click on the *Machine* item in the Operation tree and this time, select *Chuck/Fixture Display>>Setup Node* from the cascading menu. The active selection is indicated by a check next the *Setup Node* label.

When the *Setup Node* option is selected, the chuck is displayed in the graphics area whenever the any of the Setups is selected in the Operation tree.

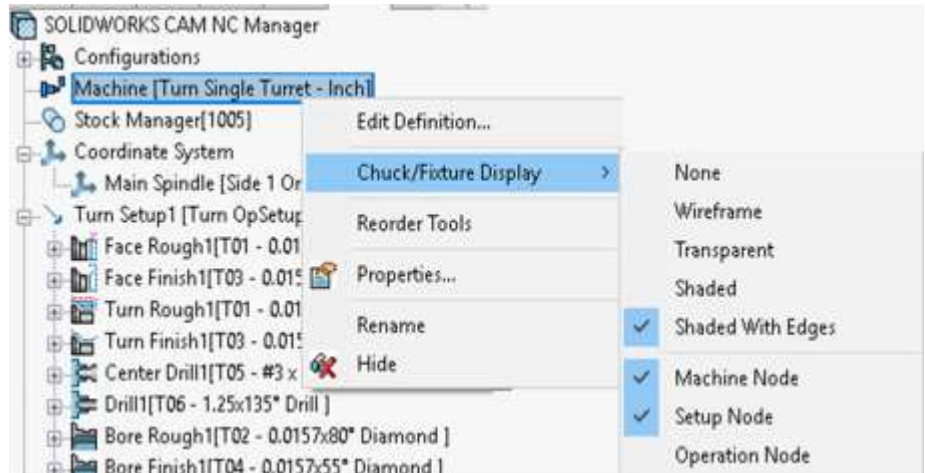

### Setting Chuck Display Options

- Left click on the *Turn Setup1* in the Operation tree. Observe that the Chuck is displayed as *Shaded with Edges* in the graphics area. As *Turn Setup1* machines *Side 1* of the part, the location of the chuck at the back of the part is correct.
- Now, mouse over the *Stock Manager* item in the Operation tree. A translucent display of the stock is displayed in the graphics area.
- Left click on the *Turn Setup2* in the Operation tree. Observe that the Chuck is displayed as *Shaded with Edges* in the graphics area. As *Turn Setup2* machines *Side 2* of the part, the location of the chuck displayed is incorrect. The chuck should be located at the opposite end, which is the front of the part. The chuck location needs to be changed.

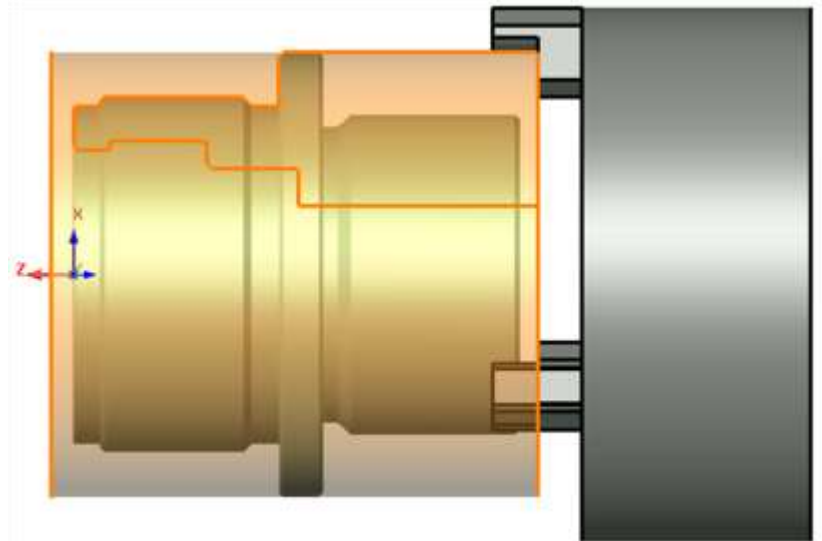

### Chuck Displayed as 'Shaded with Edges' for Turn Setup1

## Step 10: Setting the Chuck Location

As seen in the previous step, the location of the Chuck for *Turn Setup2* needs to set at the front of the part (Side 1). The Chuck location for a given step can be changed using the *Chuck Location* tab of the *Operation Setup Parameters* dialog box.

### Steps to set the Chuck Location:

1. Right click on the *Machine* item in the Operations tree and select *Chuck /FixtureDisplay>>None* from the cascading context menu.
2. Double click *Turn Setup2* in the Operation tree. The *Operation Setup Parameters* dialog box is displayed.
3. Click the *Chuck/Fixture Location* tab. Observe that, in the graphics area the outline of the WIP stock is displayed over the part model.

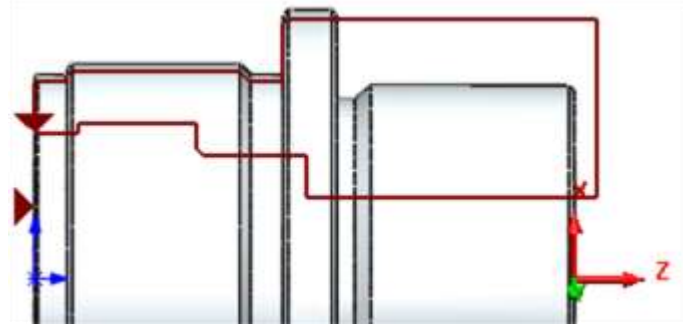

WIP stock sketch displayed over the part model

Datum triangles also display over the part model. These datum triangles indicate the location and diameter of the chuck on the WIP stock sketch.

In the *Clamping Diameter* group box of the *Operation Setup Parameters* dialog box, click on the field next to the  symbol. The mouse tip indicates that this is the *Select Entity for Clamping Diameter* field. The stock WIP is the default selected entity. Click in this field to set the focus.

4. In the graphics area, pick the horizontal edge representing the OD of the stock WIP. This action sets the clamping diameter of the chuck.

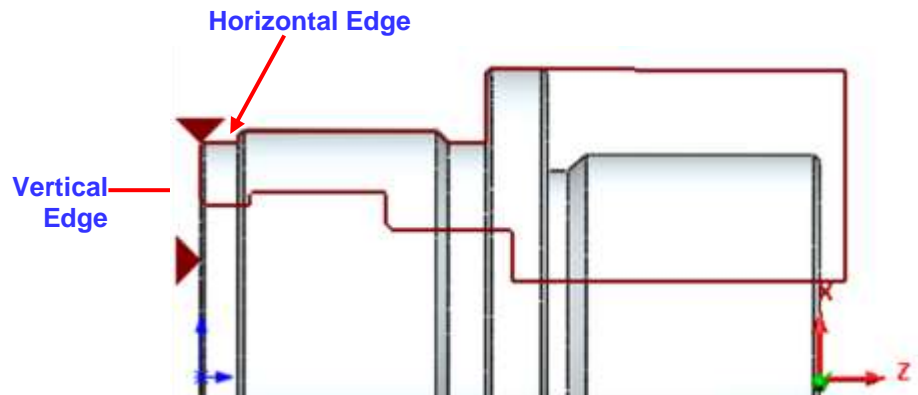

Setting the Clamping Location and Diameter on the WIP stock for Turn Setup2

In the *Clamping Location* group box, click on the field next

to the  symbol.

The mouse tip indicates that this is the *Select Entity for Z Clamping Location* field. The stock WIP is the default selected entity. Click in this field to set the focus.

5. In the graphics area, pick the vertical edge representing the machined face of the part as shown in the image on the right. This action sets the chuck face. Observe that the *Entity* field displays *CW Edge-30*.

Note that you may need to zoom in to this area in order to pick these segments easily.

The datum triangle representing the chuck clamping location and the chuck (if display is enabled) move as shown in the figure.





6. Click *OK* to apply the changes and close the *Operation Setup Parameters* dialog box.

## Step 11: Simulating the Toolpaths for Double Chucking

1.  Click the *Simulate Toolpath* button on the SOLIDWORKS CAM Command Manager.

The *Toolpath Simulation* toolbar is displayed.

2. Click the down arrow next to *End* and select *Next Setup*.
3. Select the following display options:

-  Fixture: *Shaded With Edges*
-  Stock: *Translucent*
-  Target Part: *Shaded Display*
-  Tool Holder: *Shaded With Edges*
-  Tool: *Shaded with Edges*

4. Rotate the part so you can see the part being machined in *Turn Setup1*.

5.  Click *Run* button. The simulation runs through the operations in *Turn Setup1*, then the chuck display changes to *Turn Setup2*.

6. Rotate the part so you can see the part being machined in *Turn Setup2*.

7.  Click *Run*. The toolpaths for the operations in *Turn Setup2* are simulated.

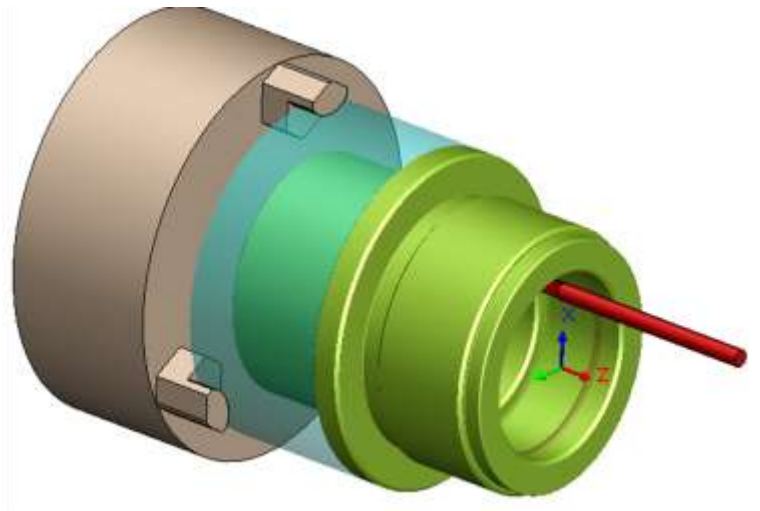

**Toolpath Simulation for Turn Setup1**

## Step 12: Post Processing Toolpaths

Post process the toolpaths in the same manner as explained in [Step 8 of the Tutorial 3](#) of this chapter.