



Πανεπιστήμιο Δυτικής Μακεδονίας
Τμήμα Μηχανολόγων Μηχανικών

Ειδικά κεφάλαια παραγωγής ενέργειας

Ενότητα 4 (α): BIOMASS

Αν. Καθηγητής Γεώργιος Μαρνέλλος

(Γραφείο 208)

Τηλ.: 24610 56690,

e-mail: gmarnellos@uowm.gr

Τμήμα Μηχανολόγων Μηχανικών



Πανεπιστήμιο Δυτικής Μακεδονίας



Με τη συγχρηματοδότηση της Ελλάδας και της Ευρωπαϊκής Ένωσης

Άδειες Χρήσης

- Το παρόν εκπαιδευτικό υλικό υπόκειται σε άδειες χρήσης Creative Commons.
- Για εκπαιδευτικό υλικό, όπως εικόνες, που υπόκειται σε άλλου τύπου άδειας χρήσης, η άδεια χρήσης αναφέρεται ρητώς.



Χρηματοδότηση

- Το παρόν εκπαιδευτικό υλικό έχει αναπτυχθεί στα πλαίσια του εκπαιδευτικού έργου του διδάσκοντα.
- Το έργο «**Ανοικτά Ψηφιακά Μαθήματα στο Πανεπιστήμιο Δυτικής Μακεδονίας**» έχει χρηματοδοτήσει μόνο τη αναδιαμόρφωση του εκπαιδευτικού υλικού.
- Το έργο υλοποιείται στο πλαίσιο του Επιχειρησιακού Προγράμματος «Εκπαίδευση και Δια Βίου Μάθηση» και συγχρηματοδοτείται από την Ευρωπαϊκή Ένωση (Ευρωπαϊκό Κοινωνικό Ταμείο) και από εθνικούς πόρους.



Ευρωπαϊκή Ένωση
Ευρωπαϊκό Κοινωνικό Ταμείο



ΥΠΟΥΡΓΕΙΟ ΠΑΙΔΕΙΑΣ ΚΑΙ ΘΡΗΣΚΕΥΜΑΤΩΝ
ΕΙΔΙΚΗ ΥΠΗΡΕΣΙΑ ΔΙΑΧΕΙΡΙΣΗΣ

Με τη συγχρηματοδότηση της Ελλάδας και της Ευρωπαϊκής Ένωσης



ΕΥΡΩΠΑΪΚΟ ΚΟΙΝΩΝΙΚΟ ΤΑΜΕΙΟ



Definitions and Types of Biomass (1/4)

ASTM/1981

Biomass is any organic matter that is available in a renewable base, including the energy crops, forest byproducts or residues, agriculture wastes or residues, manures, biodegradable fraction of MSW and the aquatic plants.

Based on the above definition, biomass is also considered:

- the products, byproducts and the residues of agriculture,
- forest and livestock production,
- the byproducts, from the industrial treatment of the above products.
- Municipal sewages and wastes and
- the organic matter from natural ecosystems, e.g. native plants,
- forests, agricultural or forest plantations.



Definitions and Types of Biomass (2/4)

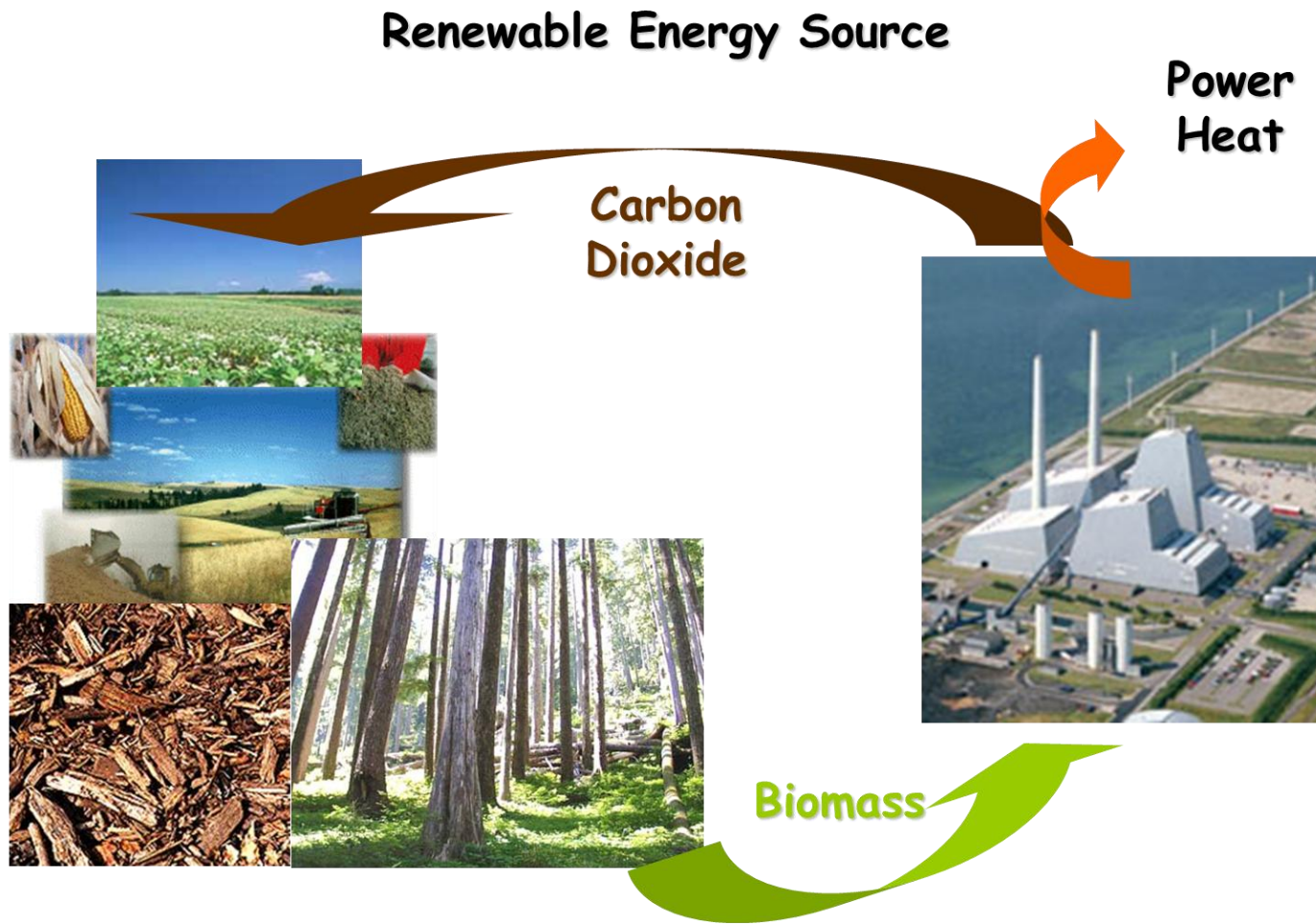

Definitions and Types of Biomass (3/4)

The renewable biomass deposits are classified in 4 categories depending on their sources:

Wastes

Plant crops.

Animal production.

Processing of agricultural products.

Crop residues.

Wood industry .

Municipal waste.

Forest

Wood.

biomass

Forest wood residues (hulls, leafs and sawdust) .

Trees, bushes and forest cycle residues.



Definitions and Types of Biomass (4/4)

Energy
crops

short cycle forest crops
leafy forest crops
annual non-woody crops
cereals
sugar crops (beets, sorghum, sugar cane)
forage crops (pastures)
oilseed crops (rapeseed, soybean, sunflower)
aquatic plants (algae, reeds, aquatic hyacinth)

Ayhan Demirbas, Energy Conversion and Management 2001



Availability – Share in the Energy Mix (1/12)

Annual World Biomass Potential: 146.000.000.000 tn.

Energy Content: 8 MJ/kg (wet biomass).
20 MJ/kg (dry biomass) (~27 MJ/kg
coal).
(~30 MJ/kg crude
oil).

80.000.000.000 (8 x 10¹⁰) tn of
equivalent coal.

72.000.000.000 (7,2 x 10¹⁰) toe (1 toe =
4,19 x 10¹⁰ J) .

3.000.000.000.000.000.000.000 (3 x 10²¹) Joule.



Availability – Share in the Energy Mix (2/12)

- Only 2 % of this huge energy potential is used today.

Share in world energy consumption:

(World energy consumption: $1,1 \times 10^{10}$ tce, $1,0 \times 10^{10}$ toe, $0,4 \times 10^{20}$ Joule).

Developed countries (50 % world population) :	3 %
Developing countries (50 % world population) :	35 %
Total world energy consumption :	14 %

Ayhan Demirbas, Energy Conversion and Management 2001.



Availability – Share in the Energy Mix (3/12)

The energy conversion of the total potential of biomass is not feasible in a renewable manner.



Biomass can provide 50 % of world energy consumption.
(United Nations Conference on Environment and Development).



Availability – Share in the Energy Mix (4/12)

	World Annual Biomass Potential	Exploitable Biomass Potential	World Energy Consumption	Energy from Biomass Today
MWh	830×10^9	58×10^9	112×10^9	17×10^9

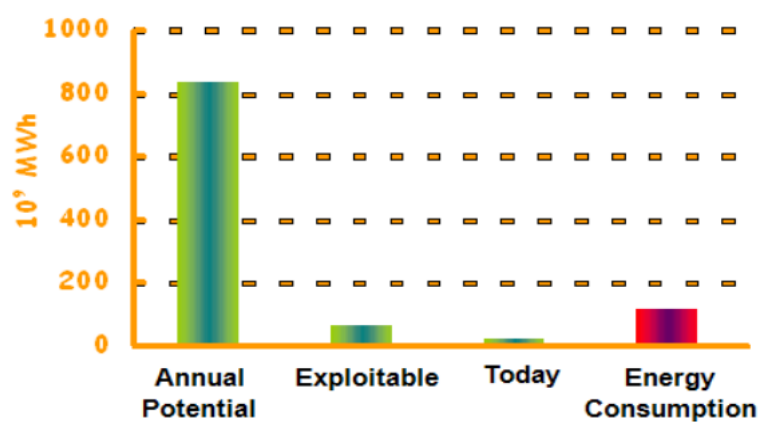

Biomass Potential

Ayhan Demirbas, Energy Conversion and Management 2001.



Availability – Share in the Energy Mix (5/12)

The potential of renewable biomass is classified accordingly:

Wood and Wood residues	64 %	Municipal Wastes	24 %
Agriculture wastes/manures	5 %	Landfill gas	5 %

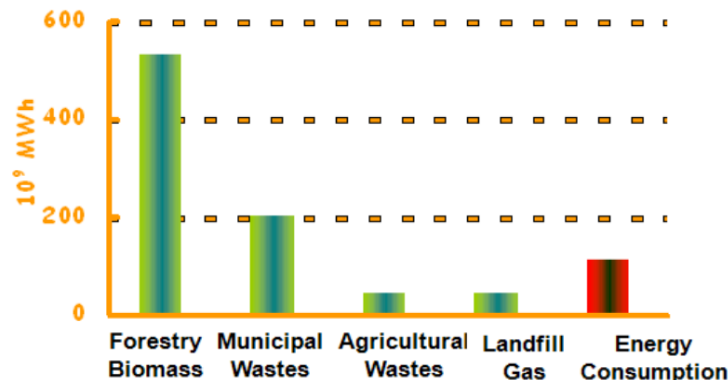

Biomass Potential

Ayhan Demirbas, Energy Conversion and Management 2001.



Availability – Share in the Energy Mix (6/12)

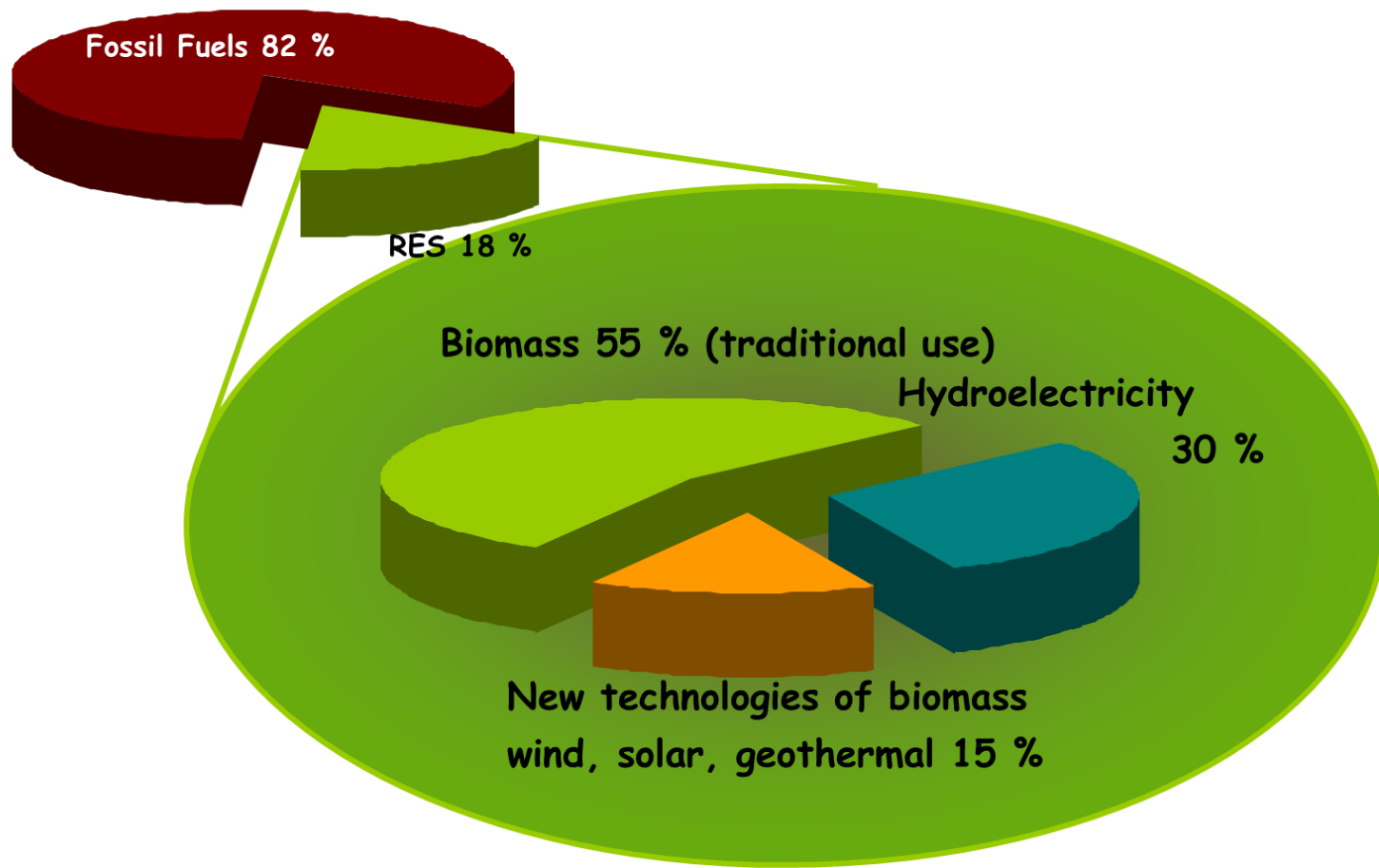

Availability – Share in the Energy Mix (7/12)

In EU-15:

2000

Total Energy Consumption	13.90 10^9 MWh.
Biomass Energy	0.55 10^9 MWh (4 %).

2020

Total energy consumption	17.0 10^9 MWh.
Biomass Energy	1.7 10^9 MWh (10 %).

wastes	0.4 – 0.6 10^9 MWh.
crops	0.1 – 0.8 10^9 MWh.
forestry biomass	0.3 – 0.4 10^9 MWh.

Andre Faaij, Energy Policy 2006.



Availability – Share in the Energy Mix (8/12)

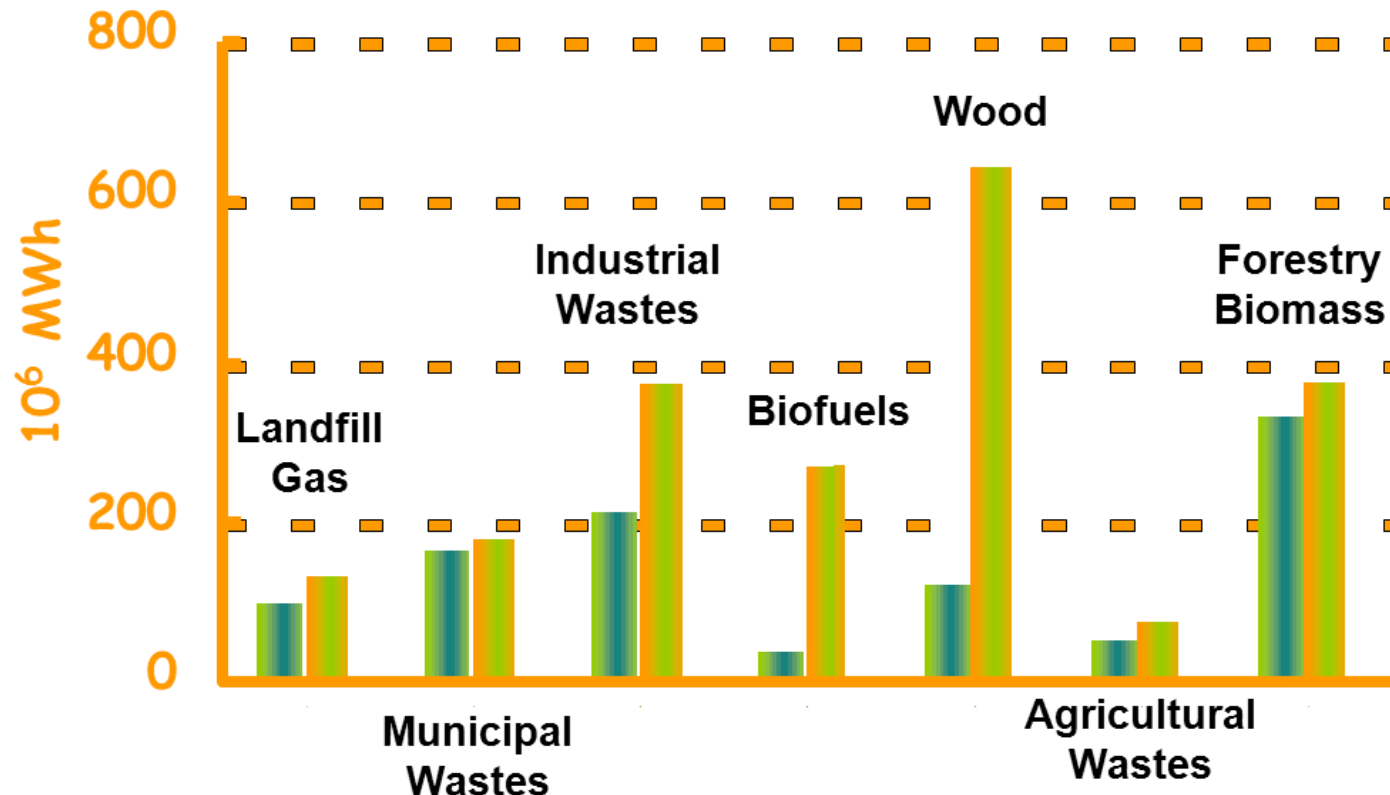

Scenarios of biomass share in the EU-15 at 2020.

Andre Faaij, Energy Policy 2006.



Availability – Share in the Energy Mix (9/12)

PJ/a (10 ¹⁵ Tons/year)	Forest Residues	Solid and by- product	Ind. black liquors	Domest. fire- wood	Wood Wastes	Refined wood fuels	Other Biomass resource	Peat	Total
Austria	150	50	0	40	18	3	9	0	270
Belgium	7	13	8	0	3	0	0	0	31
Denmark	11	5	0	3	0	4	46	0	69
Finland	96	47	135	49	0	1	11	165	504
France	38	42	0	258	111	0,3	412	0	861
Germany	142	40	0	0	81	0	511	0	774
Greece	?	?	?	?	?	?	?	?	?
Ireland	3	7	0	3	1	0	0	40	55
Italy	0	36	0	83	24	0	0	0	143
Netherl.	4	3	0	0	45	1	24	0	78
Portugal	68	27	22	0	0	0	0	0	117
Spain	59	87	23	12	52	0	386	0	618
Sweden	55	48	125	0	27	18	22	0	308
UK	16	12	0	27	175	0	70	13	300
Estonia	30	?	?	?	?	?	19,2	0	79?
Latvia	8	12	0	32	0	1	0	30	68
Poland	101	68	16	26	40	0	205	15	578
Romania	0	23	3	58	0,4	0	0,1	122	85
Slovakia	6	0,1	5	3	3	0,1	13	0	30
Slovenia	2	7	0	8	0,1	0	0	0	17
Total	767	480	336	603	580	28	1709	355	4856



Availability – Share in the Energy Mix (10/12)



Availability – Share in the Energy Mix (11/12)

Availability - Share in the Energy Mix

In Greece

Energy
Consumption

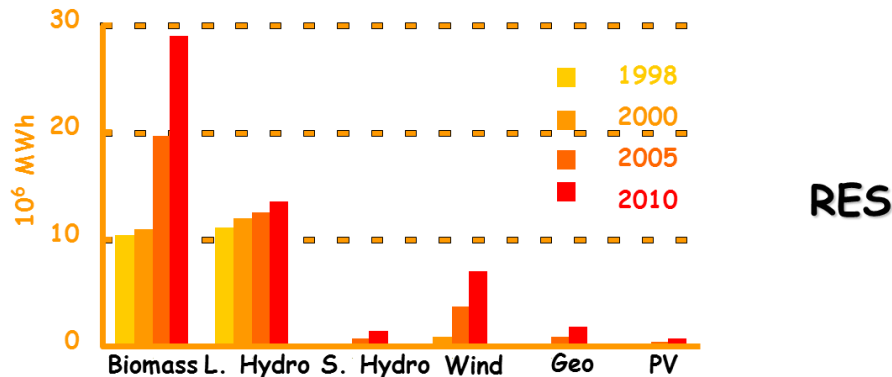
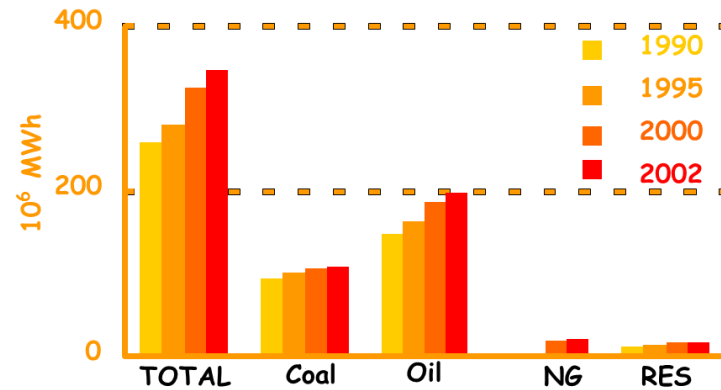

Energy & Transport in Figures, EU 2004



Availability – Share in the Energy Mix (12/12)

Availability - Share in the Energy Mix

Exploitable Biomass in Greece : 51×10^6 MWh

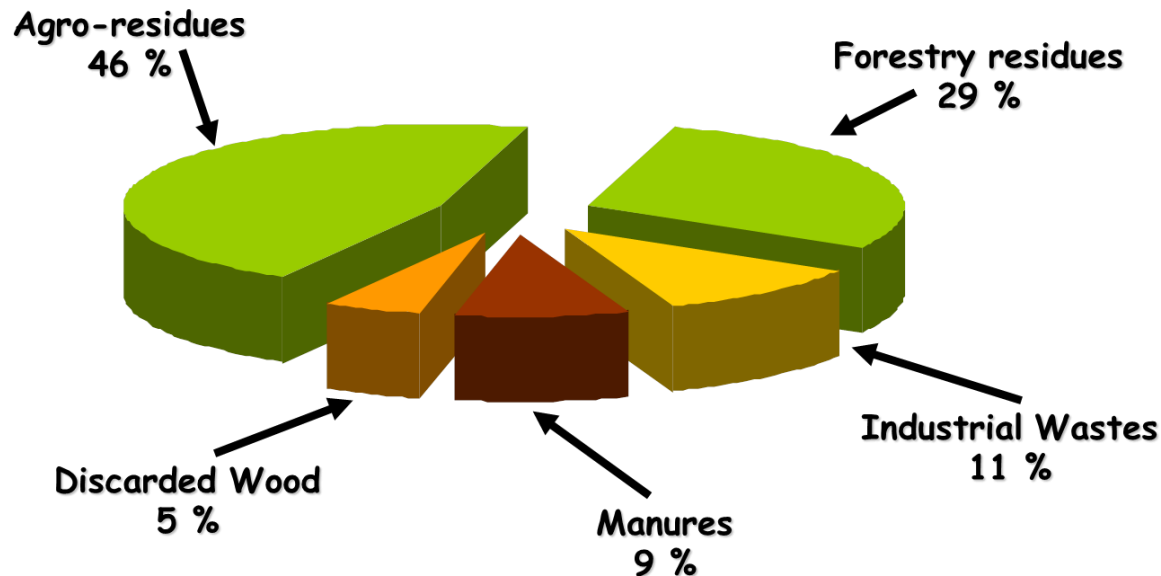

Biomass Energy Conversion Technologies

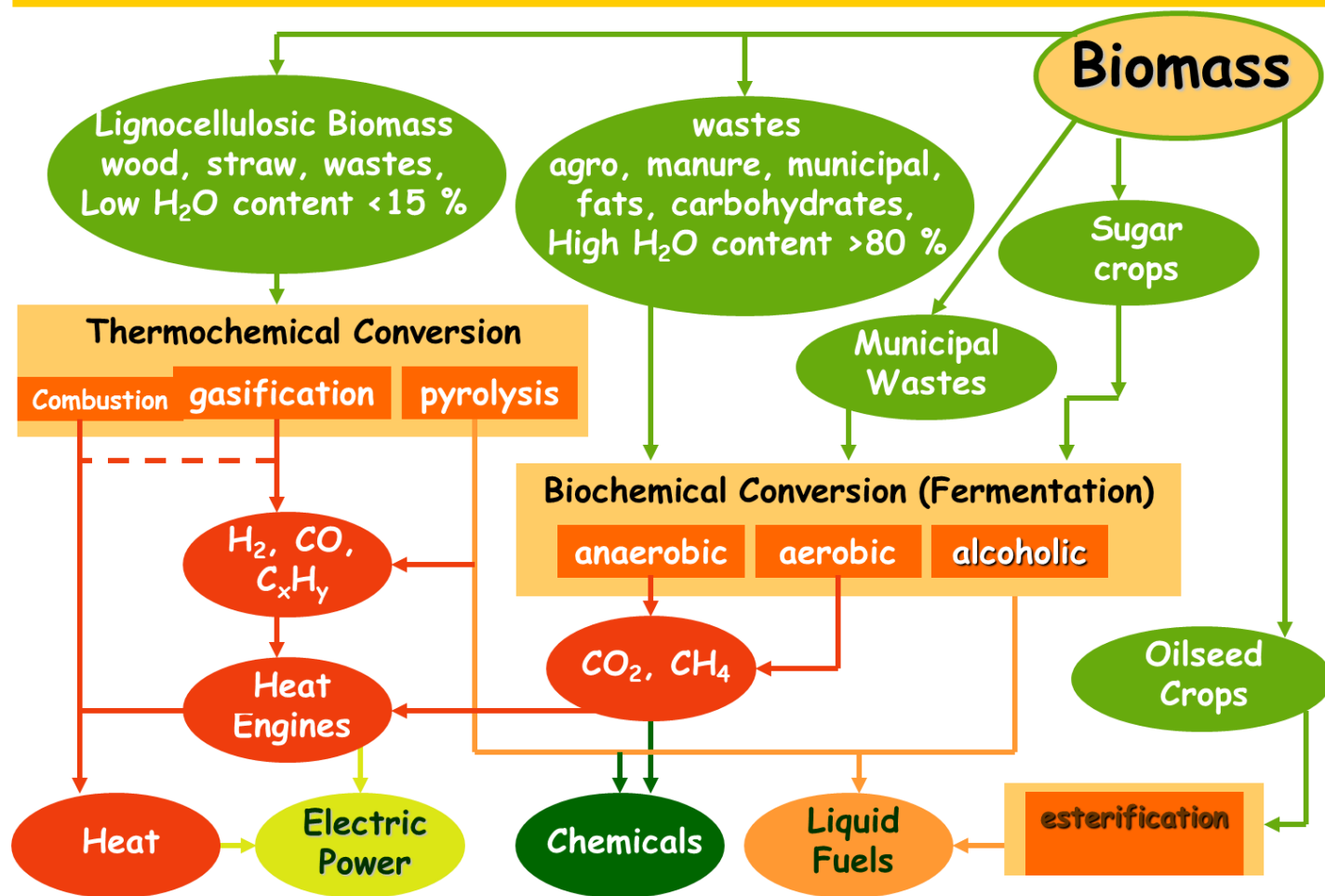

Biomass Composition

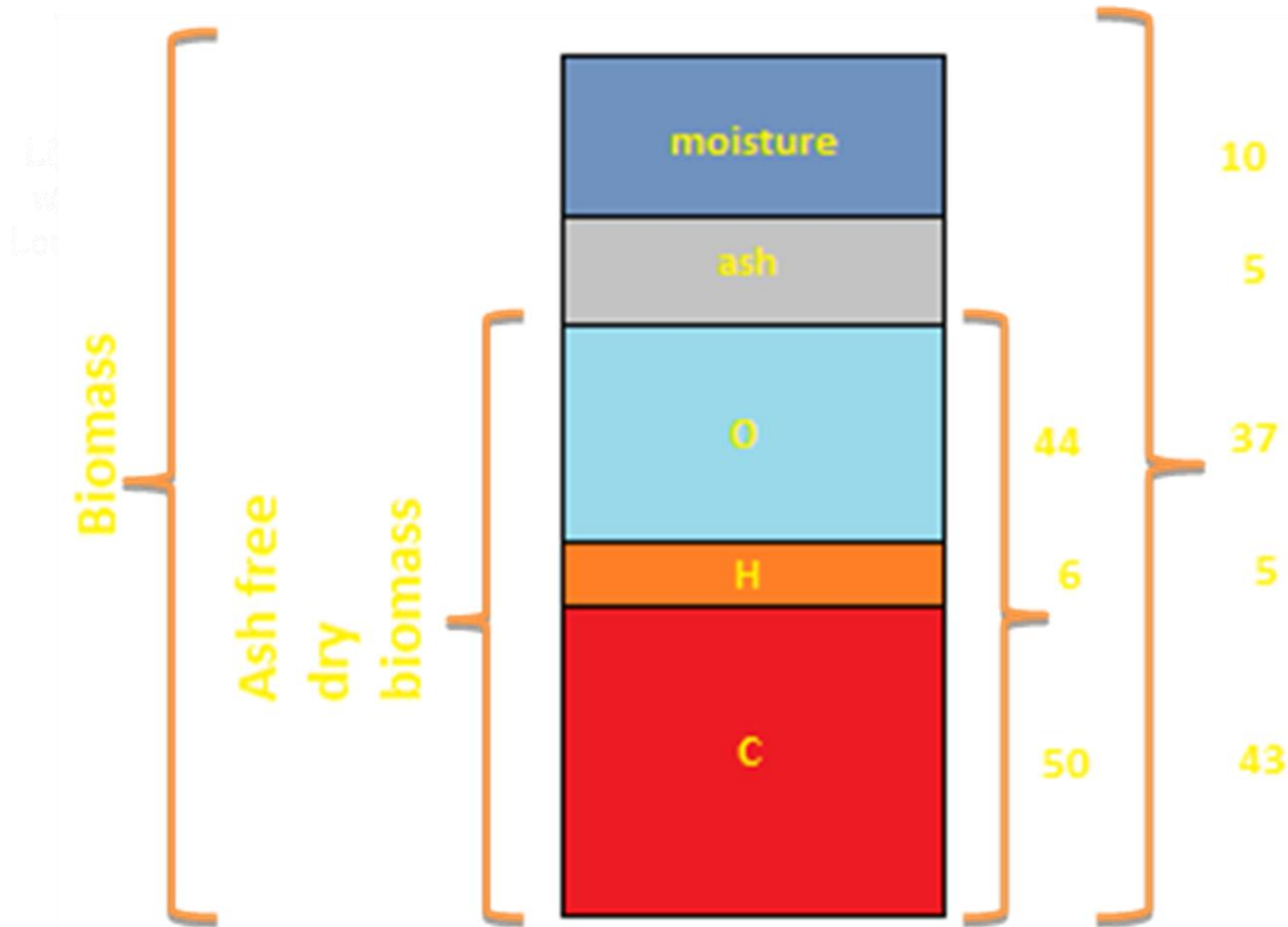

Heating Value of Biomass

High Heating Value (HHV) of ash free dry biomass is calculated from the relationship:

$$\text{HHV} = 33890,4 \times \text{C} + 144180,6 \times (\text{H} - \text{O}/8) \text{ kJ/kg.}$$

Low Heating Value (LHV) of ash free dry biomass is calculated by HHV subtracting the latent heat of condensation of steam, produced by the combustion (steam produces heat when it condenses equal to 40,7 kJ/mole of steam).



BIOMASS COMBUSTION



Biomass Combustion

- The most established way to convert biomass to heat and electricity.
- Concerns the 90 % of energy production from biomass worldwide.
- Commercialized technology.
- Compared to other thermochemical methods (gasification/pyrolysis) is the most simple technique and can easily incorporated in the existing energy production and distribution network.
- Research is focusing on the optimization of achieved efficiencies, the reduction of installation and operation costs and on the reduction of gaseous pollutants in order to remain a competitive technology compared to gasification and pyrolysis.
- The co-combustion of biomass and coal consists a high efficient and environmental friendly alternative solution.



Biomass as a fuel

	Biomass fuels				Fossil fuels		
	Urban wood ¹	Forest residues ¹	Yellow straw ²	Miscanthus ³	Peat ⁴	Coal ⁵	Natural gas ⁶
Carbon	38.3	26.3	40.3	46.3	36.3	65.0	58.2
Hydrogen	4.6	3.2	4.8	4.0	3.5	4.2	18.7
Nitrogen	0.1	0.0	0.3	0.5	0.9	1.2	21.6
Oxygen	30.9	23.7	35.5	36.4	22.1	7.0	1.5
Sulphur	0.0	0.0	0.2	0.3	0.2	0.9	0.0
Chlorine	0.0	0.0	0.7	0.2	0.1	0.0	0.0
Moisture	14.1	43.7	14.4	8.6	35.0	9.5	0.0
Ash	5.6	3.0	3.8	4.5	1.9	12.2	0.0
Fines	5.1	0.0	0.0	0.0	0.0	0.0	0.0
Ferrous	1.3	0.0	0.0	0.0	0.0	0.0	0.0
Total	100	100	100	100	100	100	100
Heating value MJ/kg(wet,HHV)	16.6	10.7	14.4	17.2	14.3	26.9	41.8
Heating value MJ/kg(wet,LHV)	15.4	9.1	13.1	16.2	12.8	25.8	38.0



Combustion

Technologies:

- Fixed bed combustion.
- Fluidized bed combustion.
- Dust combustion.

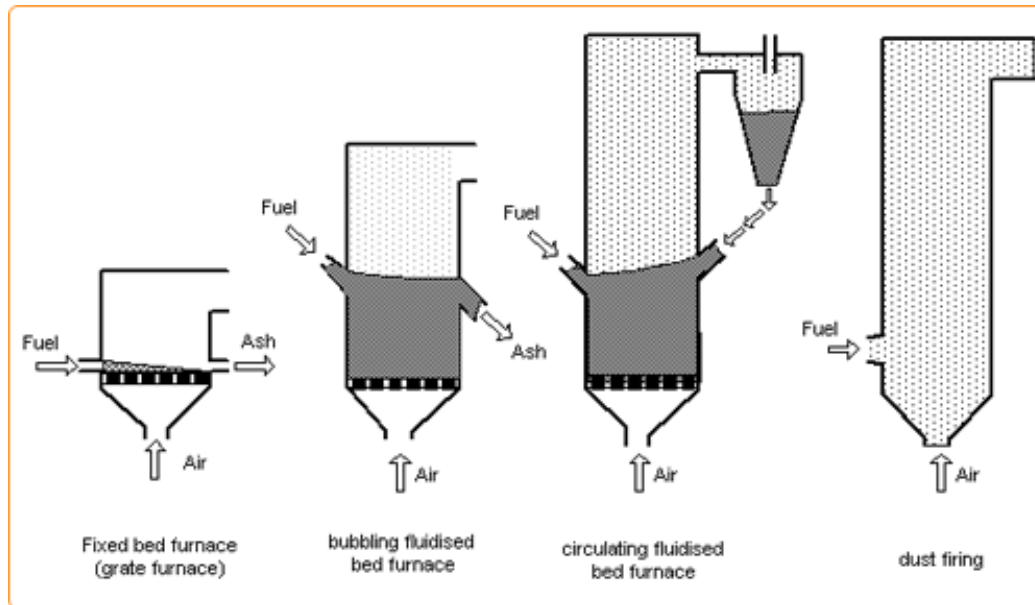

Fixed Bed Combustion (1/4)

Primary air is passing through the fixed bed, where the following processes are taking place:

- Drying of raw material.
- Gasification and,
- combustion of the solid residue (charcoal).

The effluent gases from the gasification step are oxidized with excess air (secondary air), which is fed from the top of the bed.

Screen burners are appropriate for biomass with high water content, variable particle size and high ash content.



Fixed Bed Combustion (2/4)

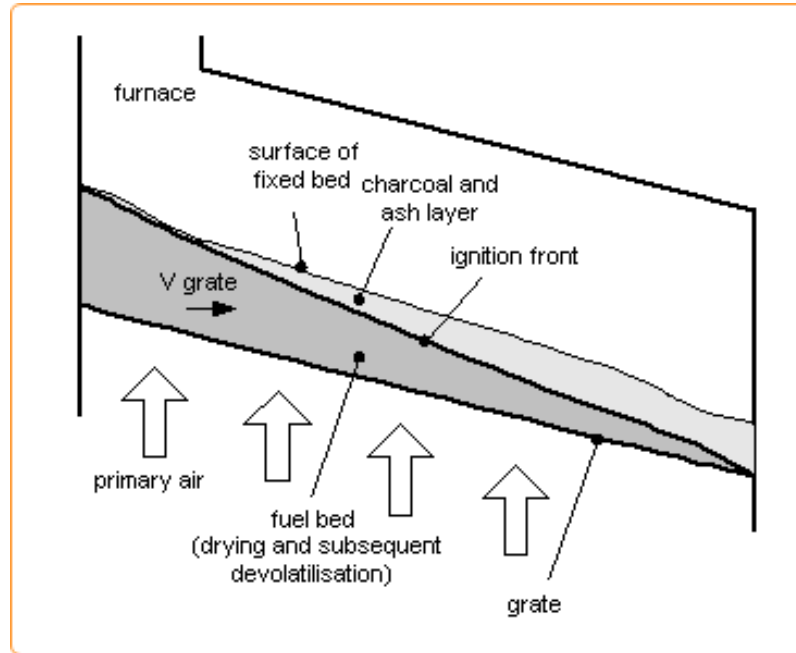

- Design and control concern the homogeneous fuel distribution, and the adequacy of primary air in the whole bed.
- An inappropriate design can lead to the melting of combustible constituents (pyrolysis), to the production of flying ash and to the increased need for excess oxygen (air).

Fixed Bed Combustion (3/4)

Available Technologies:

Rotating Screen

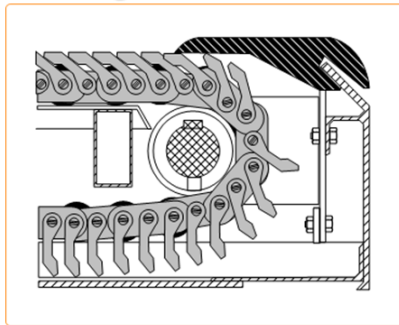

Moving Screen

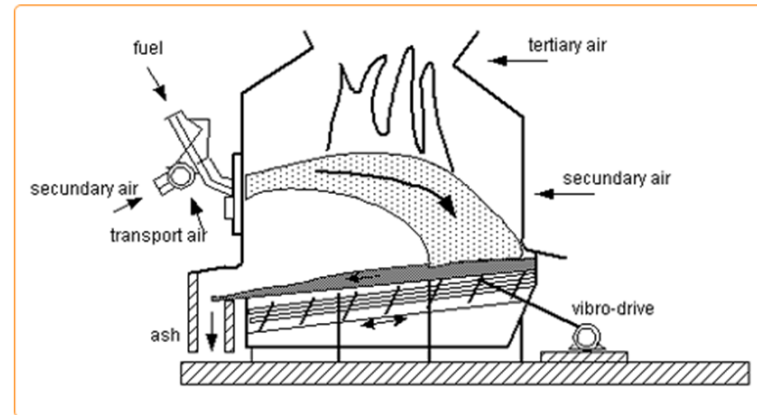
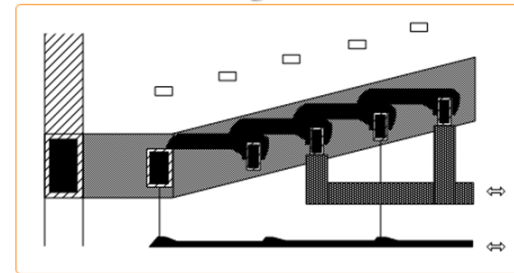

Vibrating Screen

Fixed Bed Combustion (4/4)

Screw Feed Burners:

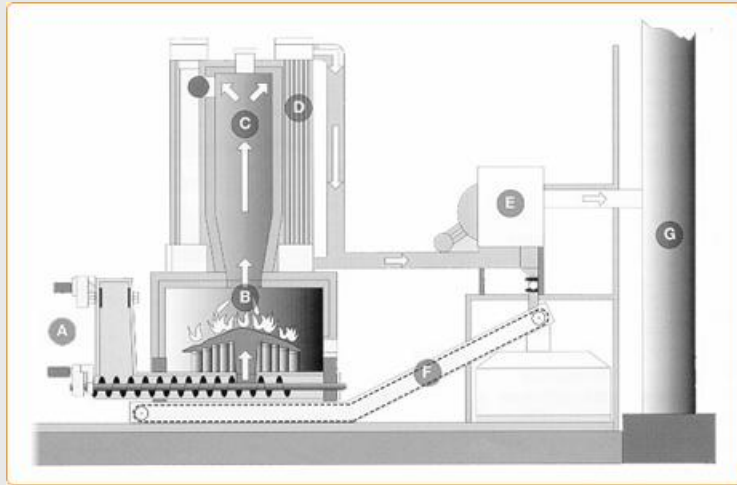

- A Fuel Entrance.
- B Primary Combustion Chamber.
- C Secondary Combustion Chamber.
- D Boiler.
- E Treatment of combustion gases.
- F Ash removal.
- G Exit of effluent gases.

- Feasible and safe technology for small/ medium burners up to 5 MWth.
- Fuels with low ash content (wood, pellets) and low particle size (50 mm) .
- For fuels with high ash content, an efficient removal system is required.

Fluidized Bed Combustion (1/3)

Fluidized Bed Burners:

- Self-mixed suspension of gas-solid mixture during the supply of primary air from the bottom of the bed (1-2,5 m/s).
- The bed is consisted by 90 – 98 % from a heated and inert solid (silica sand or dolomite, 1 mm particles diameter).
- The intensive mixing and heat transfer favor the complete combustion even at low excess air.
- Combustion temperature is sustained at low levels (800-900°C) in order to avoid sintering, through internal heat exchangers, hot gases recirculation, or water injection.
- Due to the intensive mixing conditions, a fuel mixture can be also used as a feed (wood and straw).



Fluidized Bed Combustion (2/3)

- Appropriate for >20 MWth.
- Air velocity to achieve fluidization 1.0 έως 2.5 m/s.
- The inert bed should first be heated before the fuel entrance.
- Flexibility in water content.
- Able for biomass-coal co-firing.

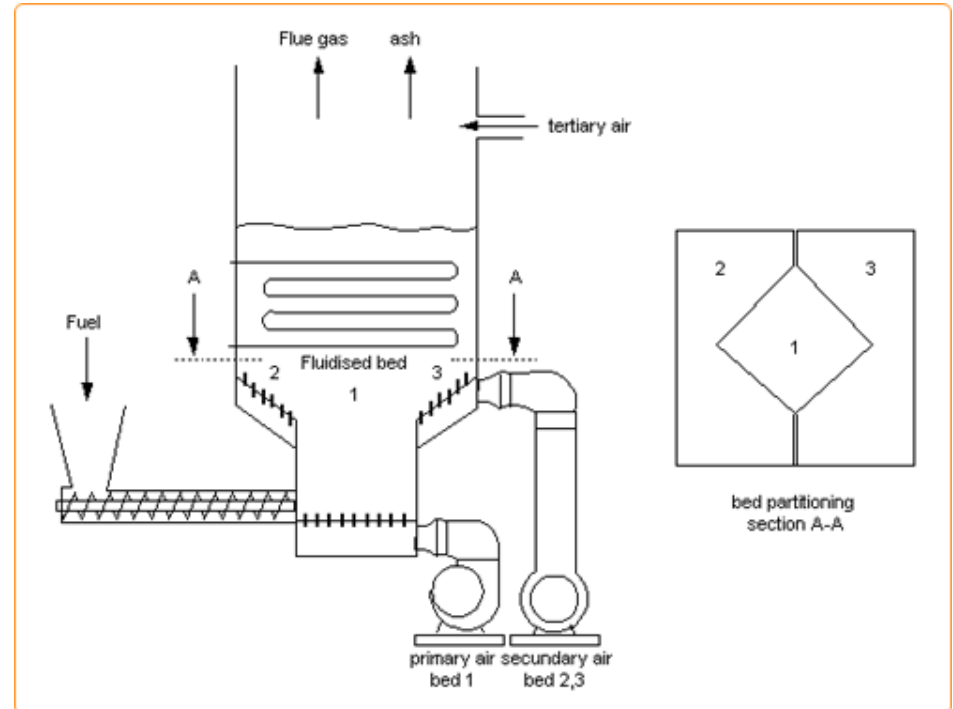

Fluidized Bed Combustion (3/3)

Recycled Bed Burners:

- With an increase in the fluidization velocity from 5 - 10 m/s and use of smaller particles (0.2 to 0.4 mm) the bed is drifted from the gaseous stream and the particles are collected to a cyclone and are re-fed to the bed.
- Higher turbulence favors the better transfer of heat and the homogeneous distribution of temperature along the whole bed.
- High efficiencies.
- High cost, economic viability for applications higher than 30 MWth.

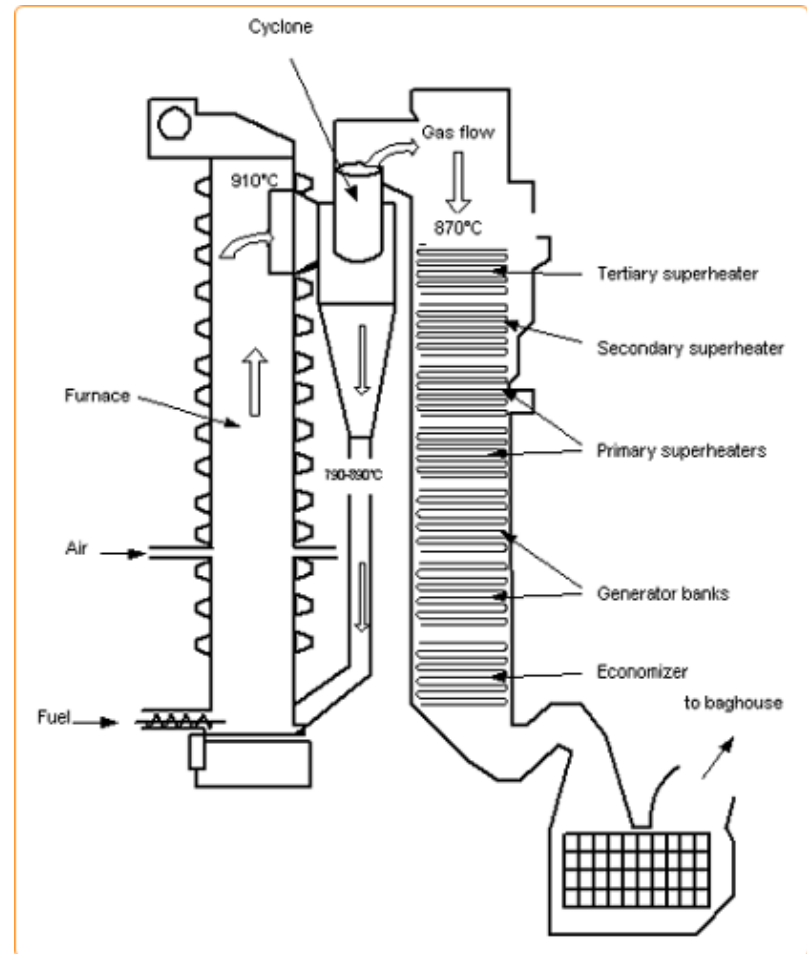

Dust Burners

Dust Burners:

- Appropriate for dusty fuels (> 2 mm).
- Particles are sprayed with primary air. Possible explosive spots (fuel feed control).
- Air-fuel mixture is entered in the combustion chamber.
- High heat release rate.
- Flexibility in feed loadings.
- For applications between 2 - 8 MW.
- Ash is drifted and settles in a chamber after the combustion chamber.
- Low air excess.
- Control of fuel residence time.

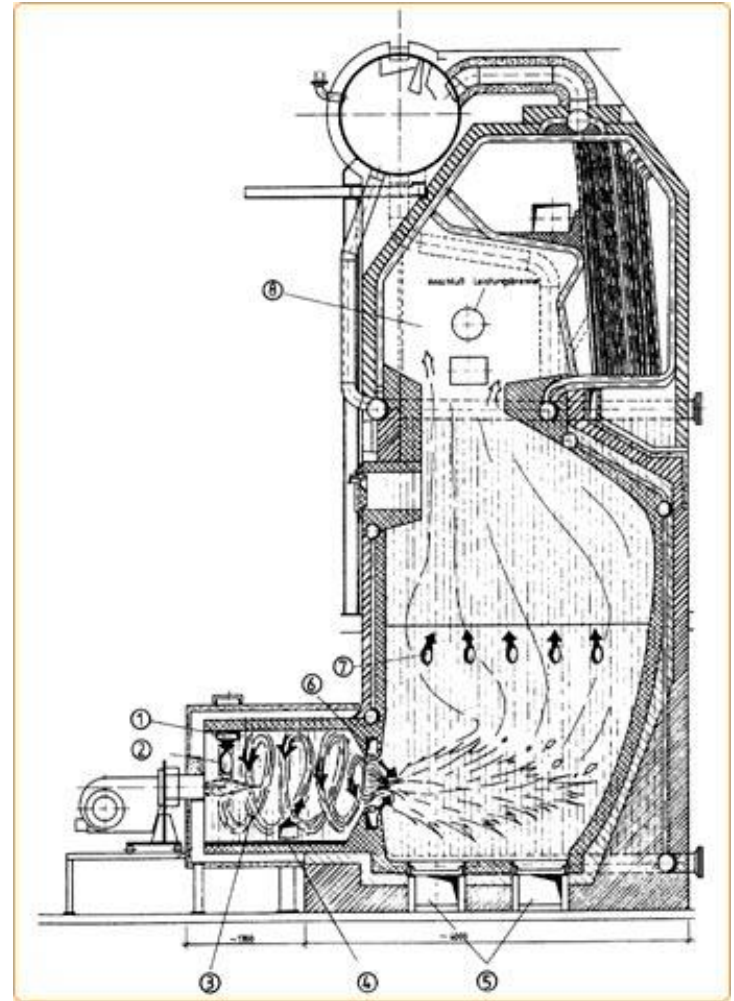

Combustion Efficiency (1/2)

100 % efficiency means that the burner is converting the overall fuel enthalpy (heat content) – this is not feasible.

The most common combustion processes achieve an efficiency from 10 -95 %.

Efficiency is calculating assuming complete combustion and is depending from :

Fuel chemistry (composition).

Temperature of combustion gases.

O₂ or CO₂ concentration at the effluents.

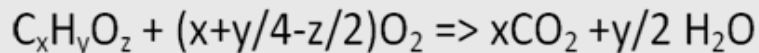

Combustion Efficiency (2/2)

Efficiency is increasing with an increase :

- in reactants temperature,
- in reactants concentration,
- in contact time,
- in contact surface,
- in fuel LHV.



Biomass Energy

Conversion Technologies (1/4)

Combustion



**Co-firing plants
in Germany**



**CHP plant from biomass combustion
in Austria**



**Pellet burner
for residential heating**

Biomass Energy

Conversion Technologies (2/4)

Co-Combustion

		<u>Overall Efficiency</u>
Biomass / Coal / Natural Gas	5 – 20 MWe	30 – 40 %

Chopped biomass is co-fed with coal or lignite. Solids are sprayed with natural gas in nozzle-type burners.

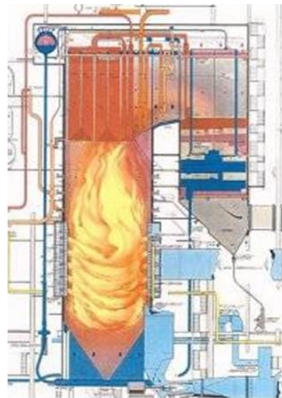

Nozzle-type burner



Biomass combustion plant

Power Generation in Rankine Heat Engines (1/6)

Rankine thermal engines are the well known steam turbines which are used in steam-electric power plants.

1. Water is supplied through a pump, which consumes work (W_{in}), in order to enter the boiler under high pressure - the efficiency of the pump is usually 90%.
2. Water absorbs heat (Q_{in}) inside the boiler and is converted to superheated steam at the pressure developed by the pump.
3. Superheated steam, under pressure, is expanded inside the turbine to produce electric work (W_{out}) through the electric generator to which it is connected - the efficiency of the turbine is 90% and saturated steam exits at the pressure of the condenser.
4. where it is converted to saturated liquid, at the same pressure, yielding heat to the environment (at 25°C).



Power Generation in Rankine Heat Engines (2/6)

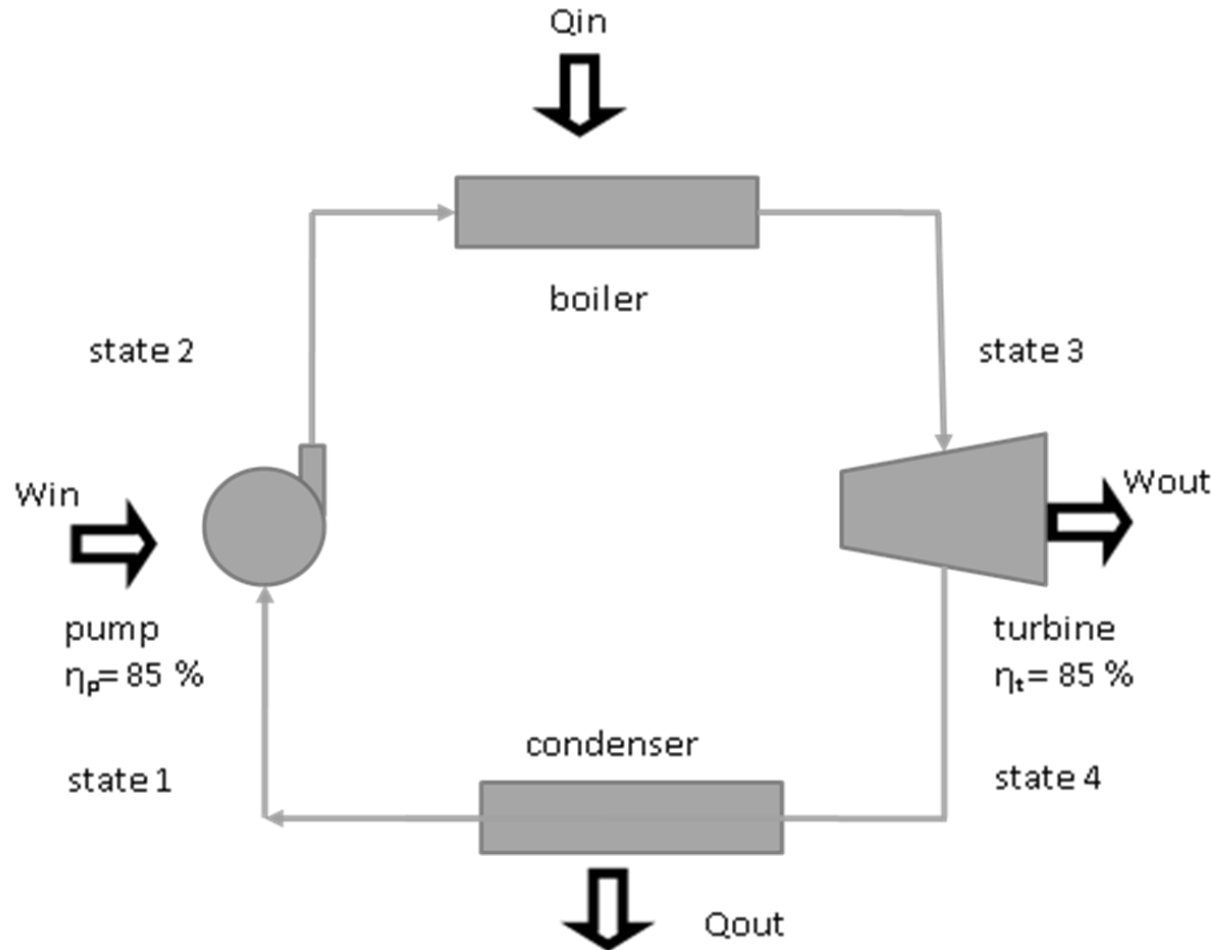

Power Generation in Rankine Heat Engines (3/6)

State 1: Saturated water at temperature T_1 and pressure P_1 - the temperature T_1 , in most advanced turbines, is 15°C above the ambient temperature, to ensure a sufficient rate of heat transfer and the pressure P_1 is the saturation pressure at this temperature (if the environment is at 25°C the temperature T_1 is 40°C and the saturation pressure is $P_1 = 7,384 \text{ kPa}$).

State 2: Pressurized water at temperature $T_2 = T_1$ and pressure P_2 - the pressure P_2 , in the most advanced turbines, is 30 Mpa .

State 3: Superheated steam at temperature T_3 and pressure $P_3 = P_2$ - the temperature T_3 , in the most advanced turbines, is 650°C .

State 4: Saturated mixture of liquid - vapor (vapor fraction ranges between 80 and 100%) at a temperature $T_4 = T_1$ and pressure $P_1 = P_4$.



Power Generation in Rankine Heat Engines (4/6)

TABLE A-7
Compressed liquid water

T °C	v m ³ /kg	u kJ/kg	h kJ/kg	s kJ/(kg·K)	v m ³ /kg	u kJ/kg	h kJ/kg	s kJ/(kg·K)	v m ³ /kg	u kJ/kg	h kJ/kg	s kJ/(kg·K)
Sal.	0.0012859	1147.8	1154.2	2.9202	0.0014524	1393.0	1407.6	3.3506	0.0016581	1585.6	1610.5	3.6848
0	0.0009977	0.04	5.04	0.0001	0.0009952	0.09	10.04	0.0002	0.0009928	0.15	15.05	0.0004
20	0.0009995	83.65	88.65	0.2956	0.0009972	83.36	93.33	0.2945	0.0009950	83.06	97.99	0.2934
40	0.0010056	166.95	171.97	0.5705	0.0010034	166.35	176.38	0.5686	0.0010013	165.76	180.78	0.5665
60	0.0010149	250.23	255.30	0.8285	0.0010127	249.36	259.49	0.8258	0.0010105	248.51	263.67	0.8232
80	0.0010268	333.72	338.85	1.0720	0.0010245	332.59	342.83	1.0668	0.0010222	331.48	346.81	1.0656
100	0.0010410	417.52	422.72	1.3030	0.0010385	416.12	426.50	1.2992	0.0010361	414.74	430.28	1.2955
120	0.0010576	501.80	507.09	1.5233	0.0010549	500.08	510.64	1.5189	0.0010522	498.40	514.19	1.5145
140	0.0010768	586.76	592.15	1.7343	0.0010737	584.68	595.42	1.7292	0.0010707	582.66	588.72	1.7242
160	0.0010988	672.62	678.12	1.9375	0.0010953	670.13	681.08	1.9317	0.0010918	667.71	684.09	1.9260
180	0.0011240	759.63	765.25	2.1341	0.0011199	756.65	767.84	2.1275	0.0011159	753.76	770.50	2.1210
200	0.0011530	848.1	853.9	2.3255	0.0011480	844.5	856.0	2.3178	0.0011433	841.0	858.2	2.3104
220	0.0011866	938.4	944.4	2.5128	0.0011805	934.1	945.9	2.5039	0.0011748	929.9	947.5	2.4953
240	0.0012264	1031.4	1037.5	2.6979	0.0012187	1026.0	1038.1	2.6872	0.0012114	1020.8	1039.0	2.6771
260	0.0012749	1127.9	1134.3	2.8830	0.0012645	1121.1	1133.7	2.8699	0.0012550	1114.6	1133.4	2.8576
280					0.0013216	1220.9	1234.1	3.0548	0.0013084	1212.5	1232.1	3.0393
300					0.0013972	1326.4	1342.3	3.2469	0.0013770	1316.6	1337.3	3.2260
320									0.0014724	1431.1	1453.2	3.4247
340									0.0016311	1567.5	1591.9	3.6546

T °C	v m ³ /kg	u kJ/kg	h kJ/kg	s kJ/(kg·K)	v m ³ /kg	u kJ/kg	h kJ/kg	s kJ/(kg·K)	v m ³ /kg	u kJ/kg	h kJ/kg	s kJ/(kg·K)
Sal.	0.002036	1785.6	1826.3	4.0139	0.0009856	0.25	29.82	0.0001	0.0009766	0.20	49.03	0.0014
0	0.0009904	0.19	20.01	0.0004	0.0009886	82.17	111.84	0.2899	0.0009804	81.00	130.02	0.2848
20	0.0009928	82.77	102.62	0.2923	0.0009951	164.04	193.89	0.5607	0.0009872	161.86	211.21	0.5527
40	0.0009992	165.17	185.16	0.5646	0.0010042	246.06	276.19	0.8154	0.0009962	242.98	292.79	0.8052
60	0.0010084	247.68	267.65	0.8206	0.0010156	328.30	358.77	1.0561	0.0010073	324.34	374.70	1.0440
80	0.0010199	330.40	350.80	1.0624	0.0010290	410.78	441.66	1.2844	0.0010201	405.88	456.89	1.2703
100	0.0010337	413.39	434.06	1.2917	0.0010445	493.59	524.93	1.5018	0.0010348	487.65	539.39	1.4857
120	0.0010496	496.76	517.76	1.5102	0.0010621	576.88	608.75	1.7098	0.0010515	569.77	622.35	1.6915
140	0.0010678	580.69	602.04	1.7193	0.0010821	660.82	693.28	1.9096	0.0010703	652.41	705.92	1.8891
160	0.0010885	665.35	687.12	1.9204	0.0011047	745.59	778.73	2.1024	0.0010912	735.69	790.25	2.0794
180	0.0011120	750.95	773.20	2.1147	0.0011302	831.4	865.3	2.2893	0.0011146	819.7	875.5	2.2634
200	0.0011388	837.7	860.5	2.3031	0.0011590	918.3	953.1	2.4711	0.0011408	904.7	961.7	2.4419
220	0.0011695	925.9	949.3	2.4870	0.0011920	1006.9	1042.6	2.6490	0.0011702	990.7	1049.2	2.6158
240	0.0012046	1016.0	1040.0	2.6674	0.0012303	1097.4	1134.3	2.8243	0.0012034	1078.1	1138.2	2.7860
260	0.0012462	1108.6	1133.5	2.8459	0.0012755	1190.7	1229.0	2.9986	0.0012415	1167.2	1229.3	2.9537
280	0.0012965	1204.7	1230.6	3.0248	0.0013304	1287.9	1327.9	3.1741	0.0012860	1258.7	1323.0	3.1200
300	0.0013596	1306.1	1333.3	3.2071	0.0014020	1390.7	1432.7	3.3539	0.0013388	1353.3	1420.2	3.2868
320	0.0014437	1415.7	1444.6	3.3979	0.0014820	1501.7	1546.5	3.5426	0.0014032	1452.0	1522.1	3.4557
340	0.0015684	1539.7	1571.0	3.6075	0.0016265	1626.6	1675.4	3.7494	0.0014838	1556.0	1630.2	3.6291
360	0.0018226	1702.5	1739.3	3.8772	0.0018691	1781.4	1837.5	4.0012	0.0015884	1667.2	1746.6	3.8101
380												



Power Generation in Rankine Heat Engines (5/6)

TABLE A-6

Superheated water (Continued)

T °C	P = 15.0 MPa (342.24°C)				P = 17.5 MPa (354.75°C)				P = 20.0 MPa (365.01°C)			
	v m ³ /kg	u kJ/kg	h kJ/kg	s kJ/(kg·K)	v m ³ /kg	u kJ/kg	h kJ/kg	s kJ/(kg·K)	v m ³ /kg	u kJ/kg	h kJ/kg	s kJ/(kg·K)
Sat.	0.010337	2455.5	2610.5	5.3098	0.007920	2390.2	2529.8	5.1419	0.005834	2293.0	2409.7	4.9269
350	0.011470	2520.4	2692.4	5.4421								
400	0.015649	2740.7	2975.5	5.6811	0.012447	2685.0	2902.9	5.7213	0.009642	2619.3	2818.1	5.5540
450	0.018445	2879.5	3156.2	6.1404	0.015174	2844.2	3102.7	6.0184	0.012695	2806.2	3060.1	5.9017
500	0.02080	2996.6	3305.6	6.3443	0.017358	2970.3	3274.1	6.2383	0.014769	2942.9	3238.2	6.1401
550	0.02293	3104.7	3448.6	6.5199	0.019289	3083.9	3421.4	6.4230	0.016656	3062.4	3393.5	6.3340
600	0.02491	3208.6	3582.3	6.6776	0.02105	3181.5	3560.1	6.5866	0.018178	3174.0	3537.6	6.5009
650	0.02680	3310.3	3712.3	6.8224	0.02274	3296.0	3693.9	6.7357	0.019693	3281.4	3675.3	6.6506
700	0.02861	3410.9	3840.1	6.9572	0.02434	3398.7	3824.6	6.8738	0.02113	3386.4	3809.0	6.7921
800	0.03210	3610.9	4092.4	7.2040	0.02738	3601.8	4081.1	7.1244	0.02385	3592.7	4069.7	7.0554
900	0.03546	3811.9	4343.8	7.4270	0.03031	3804.7	4335.1	7.3507	0.02645	3797.5	4328.4	7.2800
1000	0.03875	4015.4	4598.6	7.6348	0.03316	4009.3	4598.5	7.5569	0.02897	4003.1	4582.5	7.4821
1100	0.04200	4222.6	4852.6	7.8283	0.03597	4216.9	4845.4	7.7531	0.03145	4211.3	4840.2	7.6674
1200	0.04523	4433.8	5112.3	8.0108	0.03876	4429.3	5105.6	7.9360	0.03391	4428.6	5101.0	7.8507
1300	0.04845	4649.1	5376.0	8.1840	0.04154	4643.5	5370.5	8.1093	0.03636	4638.0	5365.1	8.0441
	P = 25.0 MPa				P = 30.0 MPa				P = 35.0 MPa			
375	0.0019731	1798.7	1848.0	4.0320	0.0017892	1737.8	1791.5	3.8305	0.0017003	1702.9	1762.4	3.8722
400	0.006004	2430.1	2580.2	5.1418	0.002790	2057.4	2151.1	4.4728	0.002100	1914.1	1927.0	4.2126
425	0.007881	2609.2	2806.3	5.4723	0.005303	2455.1	2614.2	5.1504	0.003428	2263.4	2373.4	4.7747
450	0.009182	2720.7	2949.7	5.6744	0.006735	2619.3	2821.4	5.4424	0.004661	2456.7	2572.4	5.1562
500	0.011123	2884.3	3162.4	5.9592	0.008678	2820.7	3081.1	5.7905	0.006927	2761.9	2894.4	5.6299
550	0.012724	3017.5	3335.6	6.1705	0.010166	2970.3	3275.4	6.0342	0.008345	2921.9	3013.0	5.8958
600	0.014137	3137.5	3491.4	6.3602	0.011448	3100.5	3443.9	6.2351	0.009527	3082.0	3195.5	6.1170
650	0.015433	3251.6	3637.4	6.5226	0.012596	3221.0	3596.9	6.4058	0.010575	3189.5	3359.9	6.3019
700	0.016646	3361.3	3777.5	6.6707	0.013661	3335.8	3745.6	6.5606	0.011533	3309.6	3519.5	6.4659
800	0.018912	3574.3	4047.1	6.9345	0.015623	3555.5	4024.2	6.8332	0.013278	3526.7	4001.5	6.7450
900	0.021045	3783.0	4309.1	7.1680	0.017448	3768.5	4291.9	7.0718	0.014853	3745.0	4274.9	6.9365
1000	0.02310	3990.9	4568.5	7.3802	0.019198	3973.8	4554.7	7.2867	0.016410	3966.7	4541.1	7.2084
1100	0.02512	4200.2	4828.2	7.5765	0.020993	4189.2	4816.3	7.4845	0.017895	4178.3	4804.6	7.4037
1200	0.02711	4412.0	5089.9	7.7606	0.022568	4401.3	5079.0	7.6692	0.019360	4390.7	5066.3	7.5810
1300	0.02910	4626.9	5354.4	7.9342	0.024298	4618.0	5344.0	7.8432	0.020815	4595.1	5333.6	7.7603
	P = 40.0 MPa				P = 50.0 MPa				P = 60.0 MPa			
375	0.0016407	1677.1	1742.8	3.8299	0.0015584	1638.0	1716.6	3.7639	0.0015028	1609.4	1699.5	3.7141
400	0.0019077	1854.6	1930.9	4.1135	0.0017309	1738.1	1874.6	4.0031	0.0016336	1745.4	1843.4	3.9318
425	0.002532	2096.9	2198.1	4.5029	0.002007	1959.7	2096.0	4.2734	0.0018165	1892.7	2001.7	4.1626
450	0.003593	2365.1	2512.8	4.9469	0.002486	2159.6	2284.0	4.5884	0.0022985	2053.3	2179.0	4.4121
500	0.005622	2678.4	2903.3	5.4700	0.003892	2525.5	2720.1	5.1726	0.002958	2390.6	2567.9	4.9821
550	0.006964	2869.7	3149.1	5.7785	0.005118	2763.6	3019.5	5.5485	0.003956	2658.8	2896.2	5.3441
600	0.008094	3022.6	3346.4	6.0144	0.006112	2942.0	3247.6	5.8178	0.004834	2861.1	3151.2	5.6452
650	0.009063	3158.0	3520.6	6.2054	0.006966	3093.5	3441.8	6.0342	0.005595	3028.8	3364.5	5.8829
700	0.009941	3283.6	3681.2	6.3750	0.007727	3230.5	3616.8	6.2189	0.006272	3177.2	3553.5	6.0824
800	0.011523	3517.8	3978.7	6.6662	0.009076	3479.8	3933.6	6.5290	0.007459	3441.5	3893.1	6.4109
900	0.012962	3739.4	4257.9	6.9150	0.010283	3710.3	4224.4	6.7682	0.008508	3681.0	4191.5	6.6805
1000	0.014324	3954.6	4527.6	7.1358	0.011411	3930.5	4501.1	7.0146	0.009480	3905.1	4475.2	6.9127
1100	0.015642	4167.4	4793.1	7.3364	0.012496	4145.7	4770.5	7.2184	0.010409	4124.1	4749.6	7.1135
1200	0.016940	4380.1	5057.7	7.5224	0.013561	4359.1	5037.2	7.4058	0.011317	4338.2	5017.2	7.3083
1300	0.018229	4594.3	5323.5	7.6969	0.014616	4572.8	5303.6	7.5808	0.012215	4551.4	5284.3	7.4837



Power Generation in Rankine Heat Engines (6/6)

TABLE A-4

Saturated water—Temperature table

Temp., $T^{\circ}\text{C}$	Sat. press., P_{sat} kPa	Specific volume, m^3/kg		Internal energy, kJ/kg			Enthalpy, kJ/kg			Entropy, kJ/(kg · K)		
		Sat. liquid, v_f	Sat. vapor, v_g	Sat. liquid, u_f	Evap., u_{fg}	Sat. vapor, u_g	Sat. liquid, h_f	Evap., h_{fg}	Sat. vapor, h_g	Sat. liquid, s_f	Evap., s_{fg}	Sat. vapor, s_g
0.01	0.6113	0.001000	206.14	0.0	2375.3	2375.3	0.01	2501.3	2501.4	0.000	9.1562	9.1562
5	0.8721	0.001000	147.12	20.97	2361.3	2382.3	20.98	2489.6	2510.6	0.0761	8.9496	9.0257
10	1.2276	0.001000	106.38	42.00	2347.2	2389.2	42.01	2477.7	2519.8	0.1510	8.7498	8.9008
15	1.7051	0.001001	77.93	62.99	2333.1	2396.1	62.99	2465.9	2528.9	0.2245	8.5569	8.7814
20	2.339	0.001002	57.79	83.95	2319.0	2402.9	83.96	2454.1	2538.1	0.2966	8.3706	8.6672
25	3.169	0.001003	43.36	104.88	2304.9	2409.8	104.89	2442.3	2547.2	0.3674	8.1905	8.5580
30	4.246	0.001004	32.89	125.78	2290.8	2416.6	125.79	2430.5	2556.3	0.4369	8.0164	8.4533
35	5.628	0.001006	25.22	146.67	2276.7	2423.4	146.68	2418.6	2565.3	0.5053	7.8478	8.3531
40	7.384	0.001008	19.52	167.56	2262.6	2430.1	167.57	2406.7	2574.3	0.5725	7.6845	8.2570
45	9.593	0.001010	15.26	188.44	2248.4	2436.8	188.45	2394.8	2583.2	0.6387	7.5261	8.1648
50	12.349	0.001012	12.03	209.32	2234.2	2443.5	209.33	2382.7	2592.1	0.7038	7.3725	8.0763
55	15.758	0.001015	9.568	230.21	2219.9	2450.1	230.23	2370.7	2600.9	0.7679	7.2234	7.9913
60	19.940	0.001017	7.671	251.11	2205.5	2456.6	251.13	2358.5	2609.6	0.8312	7.0784	7.9096
65	25.03	0.001020	6.197	272.02	2191.1	2463.1	272.06	2346.2	2618.3	0.8935	6.9375	7.8310
70	31.19	0.001023	5.042	292.95	2176.6	2469.6	292.98	2333.8	2626.8	0.9549	6.8004	7.7553
75	38.58	0.001026	4.131	313.90	2162.0	2475.9	313.93	2321.4	2635.3	1.0155	6.6669	7.6824
80	47.39	0.001029	3.407	334.86	2147.4	2482.2	334.91	2308.8	2643.7	1.0753	6.5369	7.6122
85	57.83	0.001033	2.828	355.84	2132.6	2488.4	355.90	2296.0	2651.9	1.1343	6.4102	7.5445
90	70.14	0.001036	2.361	376.85	2117.7	2494.5	376.92	2283.2	2660.1	1.1925	6.2866	7.4791
95	84.55	0.001040	1.982	397.88	2102.7	2500.6	397.96	2270.2	2668.1	1.2500	6.1659	7.4159



Biomass Gasification



Gasification (1/2)

Thermochemical conversion of solid or liquid fuels to biogas with:

- Air (exothermic).
- Pure oxygen (exothermic).
- Steam/air mixture (autothermal or endothermic).
- Steam (endothermic).

at

- High temperatures (650 – 1200 °C).
- Atmospheric or high pressures.

Produced Biogas Mixture: H_2 , CO , CH_4 , C_2H_6 , C_2H_4 , CO_2 , H_2O , N_2 .

Residue :

solid

- carbon .
- ash.

tar

- higher hydrocarbons.



Gasification (2/2)

- With air:** products CO, CO₂, H₂, CH₄, N₂, tar, solid residue .
biogas of low heating value (~5 MJ/m³).
possible problems associated with its combustion at gasturbines.
- With oxygen:** products CO, CO₂, H₂, CH₄, tar, solid residue (no N₂).
biogas of medium heating value (~10 – 12 MJ/m³).
the separation cost of oxygen is counterbalanced by the high quality produced biogas.
- With steam:** products CO, CO₂, H₂, CH₄, tar, solid residue (no N₂).
biogas of medium heating value (~15 – 20 MJ/m³).
the heat content of biomass is maximized through the increased thermal requirements, which decreases the overall process efficiency.
- Stages:** Drying and water evaporation.
Pyrolysis to gaseous products, heavy hydrocarbons vapours, tar and solid residue.
partial oxidation and gasification of vapors, liquids and solids.



Reactions (1/4)

Pyrolysis: during heating at 300–500 °C in the absence of oxidants; biomass is pyrolyzed to gaseous products, heavy HC vapors, tar and solid residue.

- The relevant yields to gaseous, liquid and solid products, are depending from:
 - Rate of temperature increase.
 - The final value of temperature.
 - Residence time at this zone.
- Pyrolysis is fast and is not controlling the rate of the whole process.



Reactions (2/4)

combustion: the gaseous, liquid and solid products of pyrolysis are reacted with the oxidizing agent (usually O_2) towards CO , CO_2 , H_2O .

gasification: the residue liquids and solids are reacting with the combustion products to CO , H_2 and minor quantities of gaseous HC.

reforming: hydrocarbons are converted to CO and H_2 , while the role of $CO + H_2O = CO_2 + H_2$ is significant.

The gaseous – solid reactions determine the overall efficiency.



Reactions (3/4)

- Many reactions are catalyzed from the alkalis that are contained in tar while most time a special catalyst is ad-mixed with biomass.
- Reactions are not always reach equilibrium.
- The composition of biomass is determined by:
 - feed composition,
 - water content,
 - temperature at the various zones of gasifyer,
 - residence time,
 - catalyst,
 - extent of pyrolysis, combustion, gasification and
 - reforming reactions.



Reactions (4/4)

- Gasification is not referring to the total liquid and solid products of pyrolysis due to:
 - ❖ Mass transfer limitations.
 - ❖ Chemical nature limitations.

Resulting to solid residue and tar.

- Due to high temperatures tar is deposited and it is difficult to be removed.



Gasification Steps

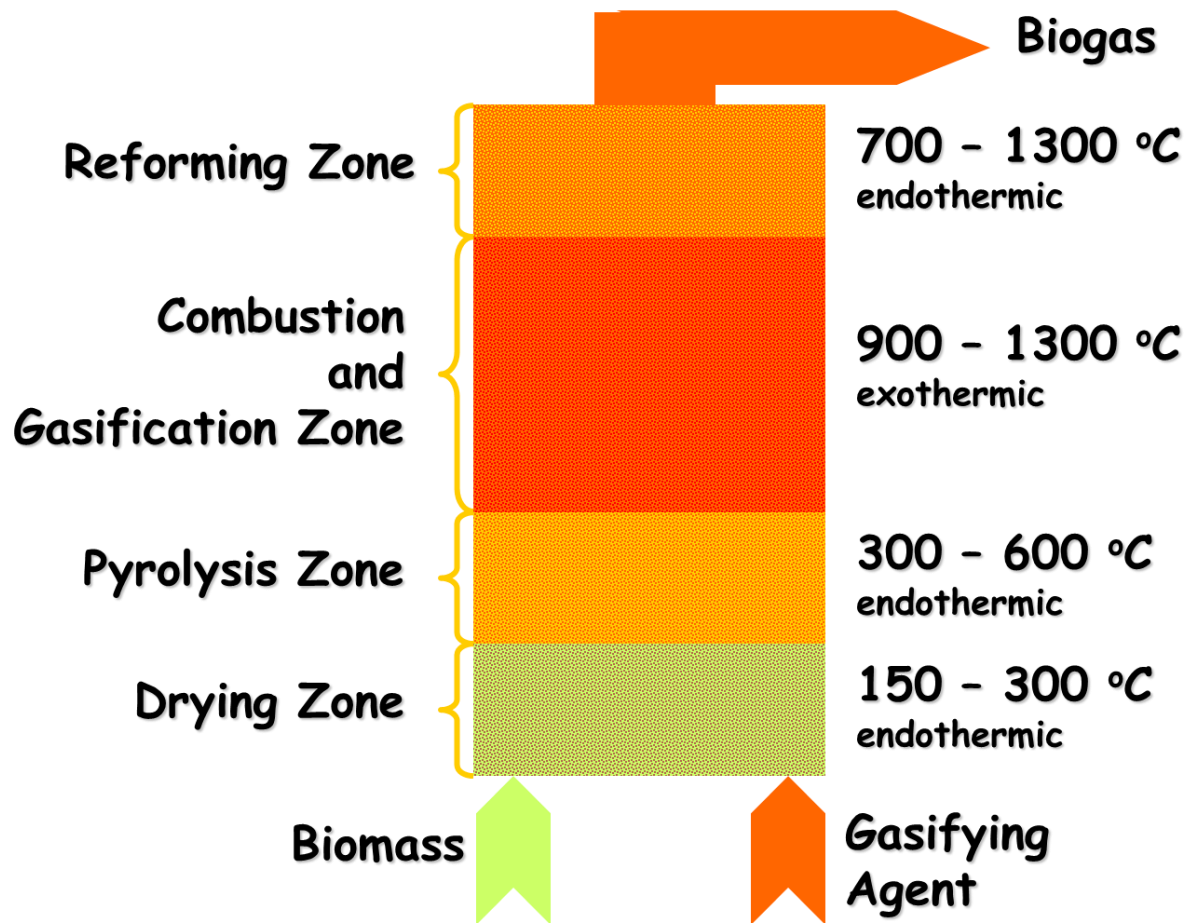

Reactions

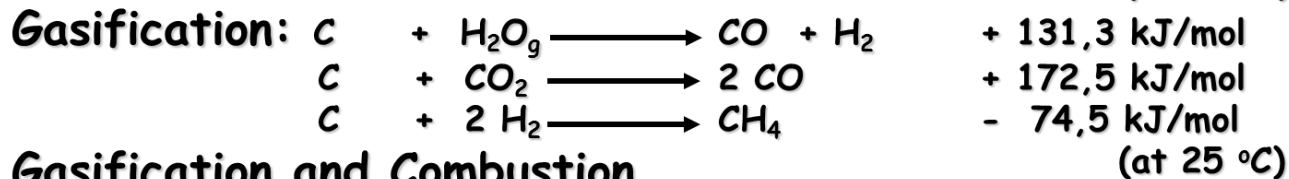
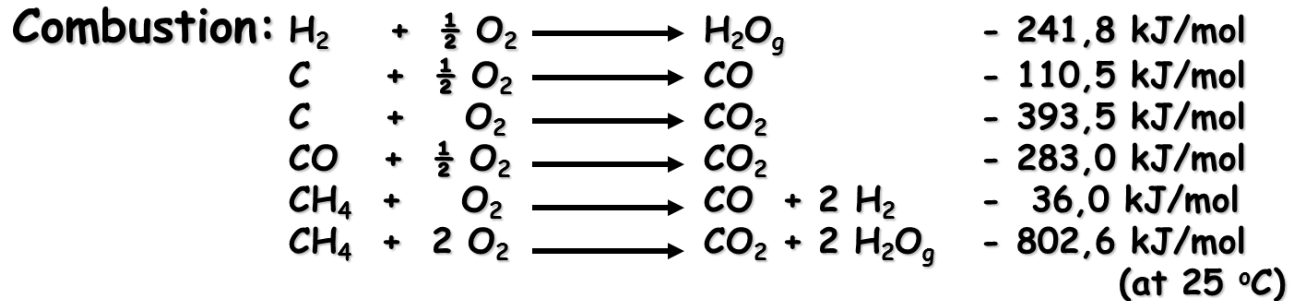
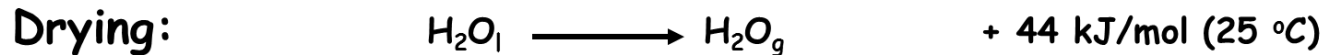

Gasification and Combustion

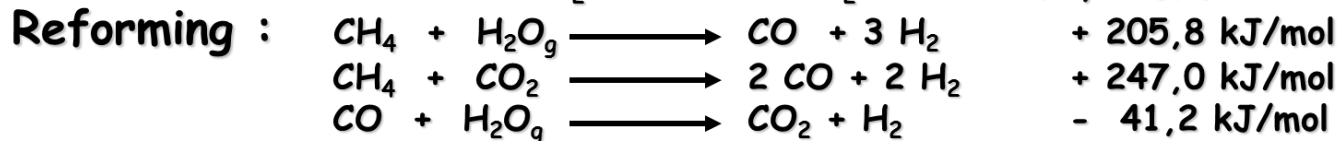
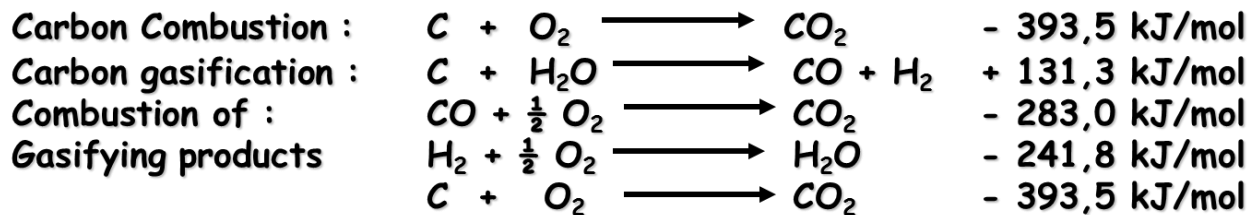

Technologies (1/2)

Fixed Bed

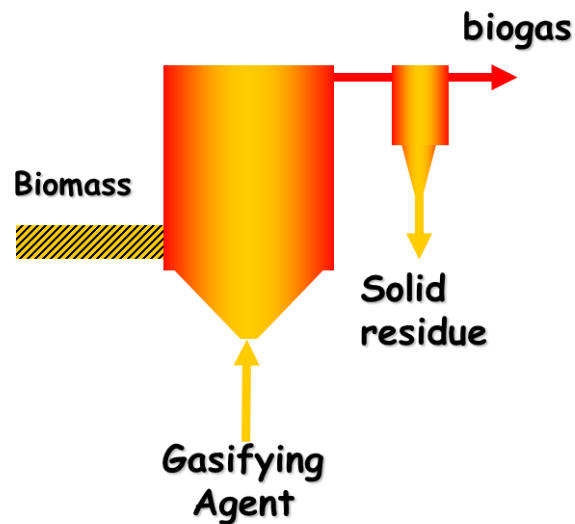

Counter-flow
Simple and applied technology
Up to 4 t/h
Low temperature biogas

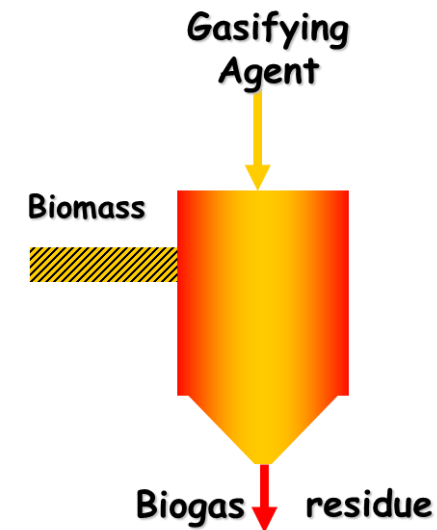

Co-flow
Simple and applied technology
Up to 500 kg/h
Max water content 35%



Technologies (2/2)

Fluidized bed.
Satisfied control of temperature,
high reaction rates.

Capacity up to 10–15 dry t/h.
Easy start up and shut down.
A catalyst for tar cracking is added.
Carbon losses with the drifted tar.

Recycled fluidized bed.
capacity > 15 t/h.
High cost.

High pressure (supercritical)
gasification.
For high water content biomass.

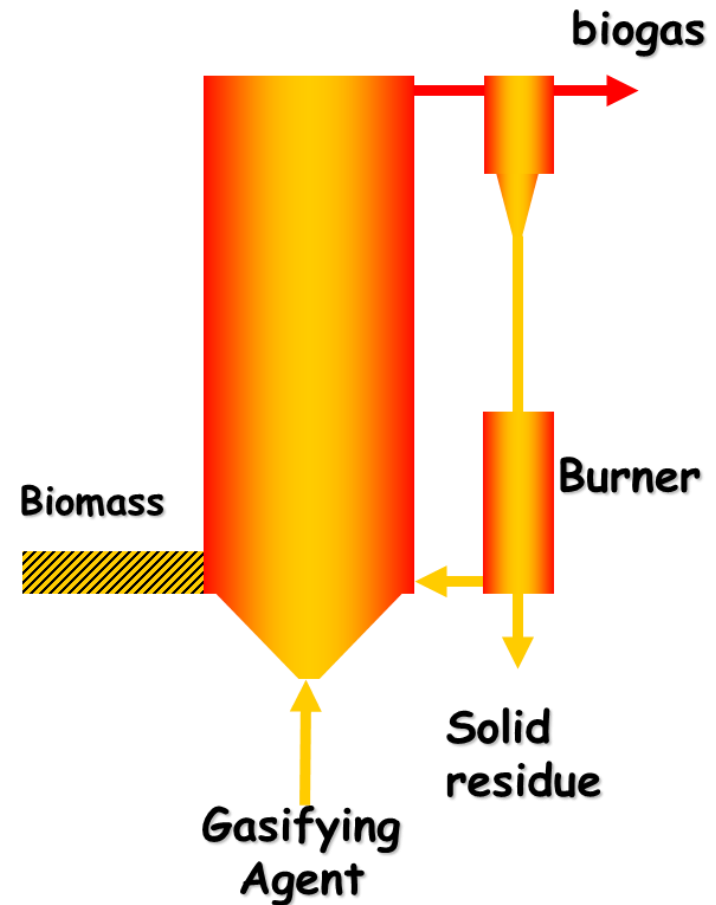

Biomass energy conversion technologies (3/4)

Gasification:

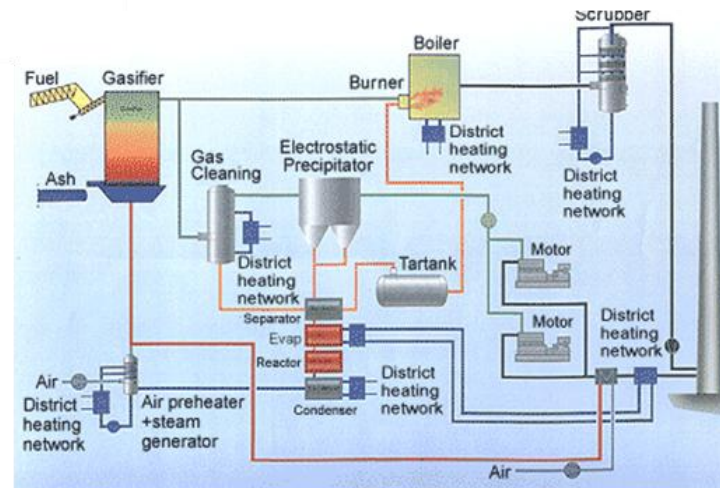
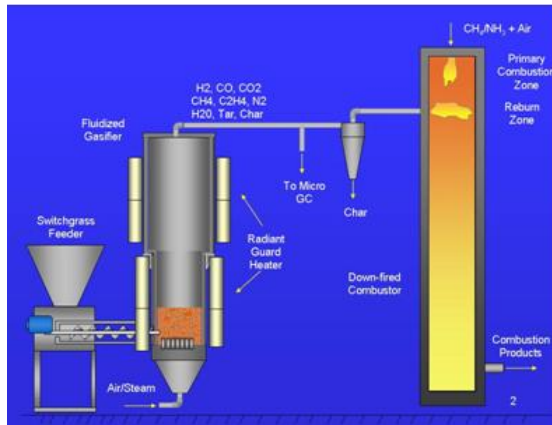
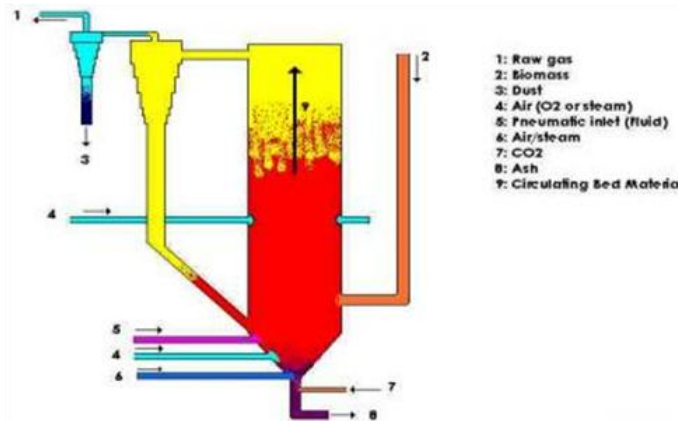

Biomass energy conversion technologies (4/4)

Gasification



Biomass Gasification Plants



Power Generation in Brayton Heat Engines (1/3)

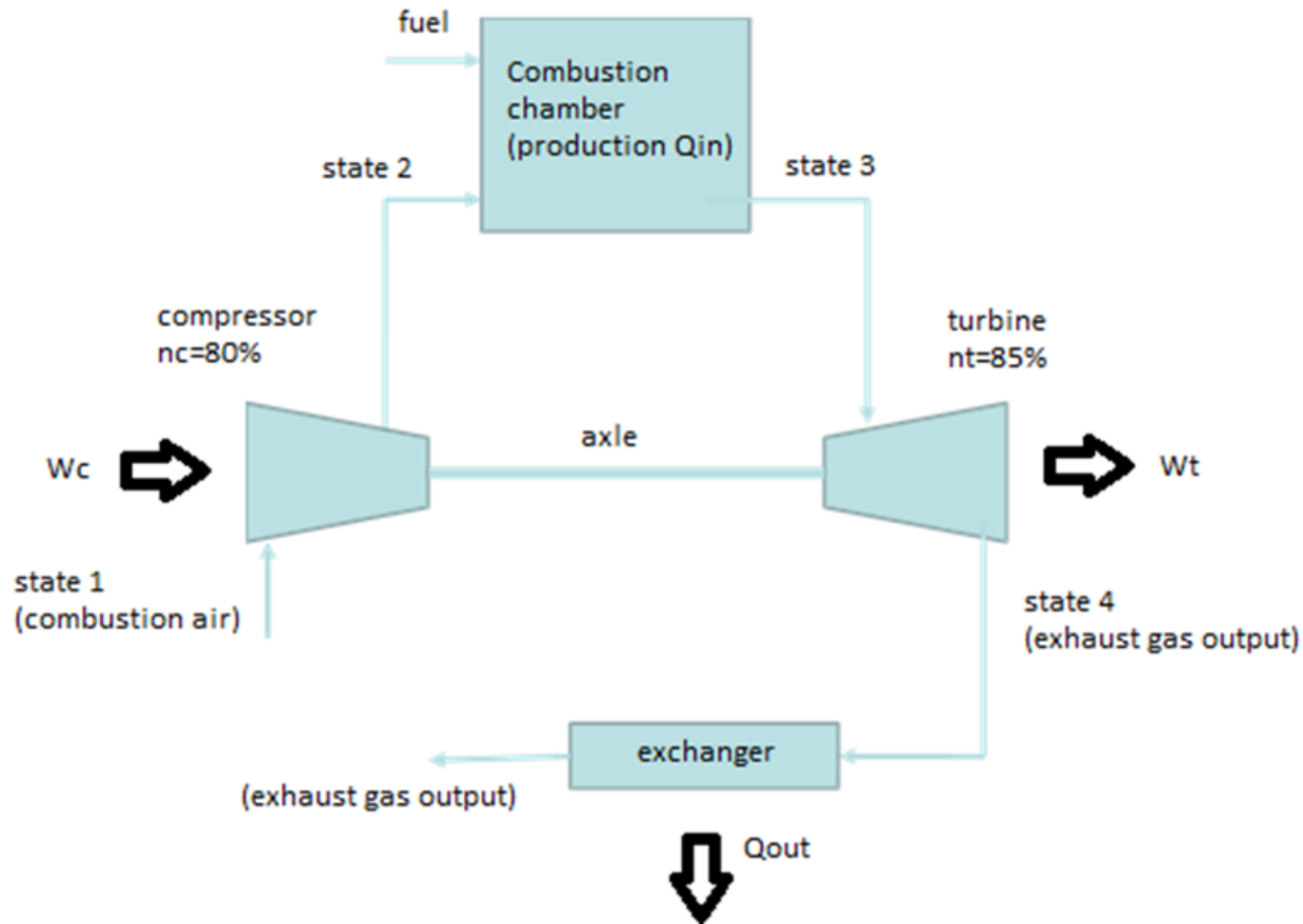

Power Generation in Brayton Heat Engines (2/3)

In the case of Brayton cycle the compressor consumes work W_c and feeds the combustion chamber with air under high pressure (P_2).

Fuel is fed in the same chamber (gasification gas) and because of the combustion that occurs there (and also because of the fuel's sensible heat that may be hot from the gasifier) combustion gases are heated (always under the pressure developed by the Compressor - $P_3 = P_2$) and expanded through the turbine producing work W_t .

After the turbine, the exhaust gases are cooled in an exchanger (yielding the greater part of their sensible heat for cogeneration or for the additional production of electricity in a Rankine cycle) and discharged into the atmosphere at a temperature over 100°C , in order to avoid the condensation of contained water vapor.



Power Generation in Brayton Heat Engines (3/3)

The work that is consumed by the compressor comes directly from the turbine, so the net work produced by the Brayton cycle is:

$$W_{net} = W_t - W_c$$

The pressure developed by the compressor is usually in the range of 10 to 15 atm, while the maximum temperature of the exhaust gas fed to it can reach 1400°C.

The excess of air supplied to the combustion chamber is determined by the desired temperature of exhaust gas which is fed to the turbine. This excess is usually large, so the composition of exhaust gases is identical to that of air.



Power Generation in combined cycle gas-steam turbine

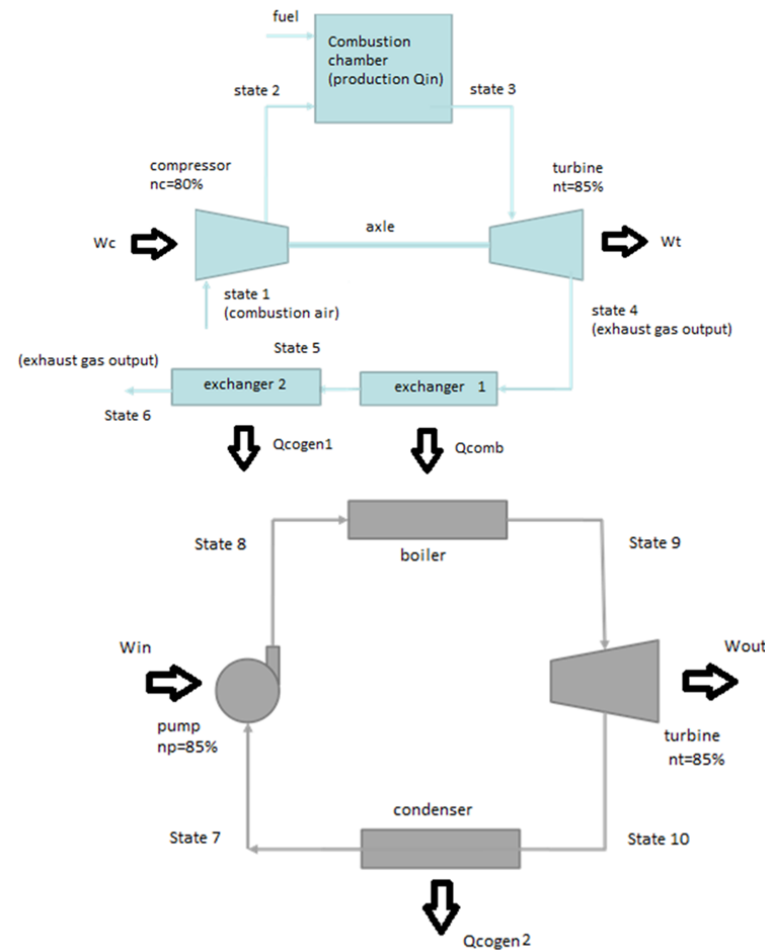

Biomass Pyrolysis



Pyrolysis (1/6)

Pyrolysis is the thermal decomposition of biomass in the absence of oxygen:

- Consists the 1st step in the combustion and gasification processes.
- Followed by the partial oxidation of the initial products.
- Low temperatures and high residence times favor the production of solid products (solid residue).
- High temperatures and high residence times favor the production of gaseous products (carbon oxides and hydrogen).
- Medium temperatures and low residence times favor the production of liquids (bio-oil).
- Flash pyrolysis or fast pyrolysis – at low residence times (less than a few seconds) has particular interest.



Products distribution vs temperature

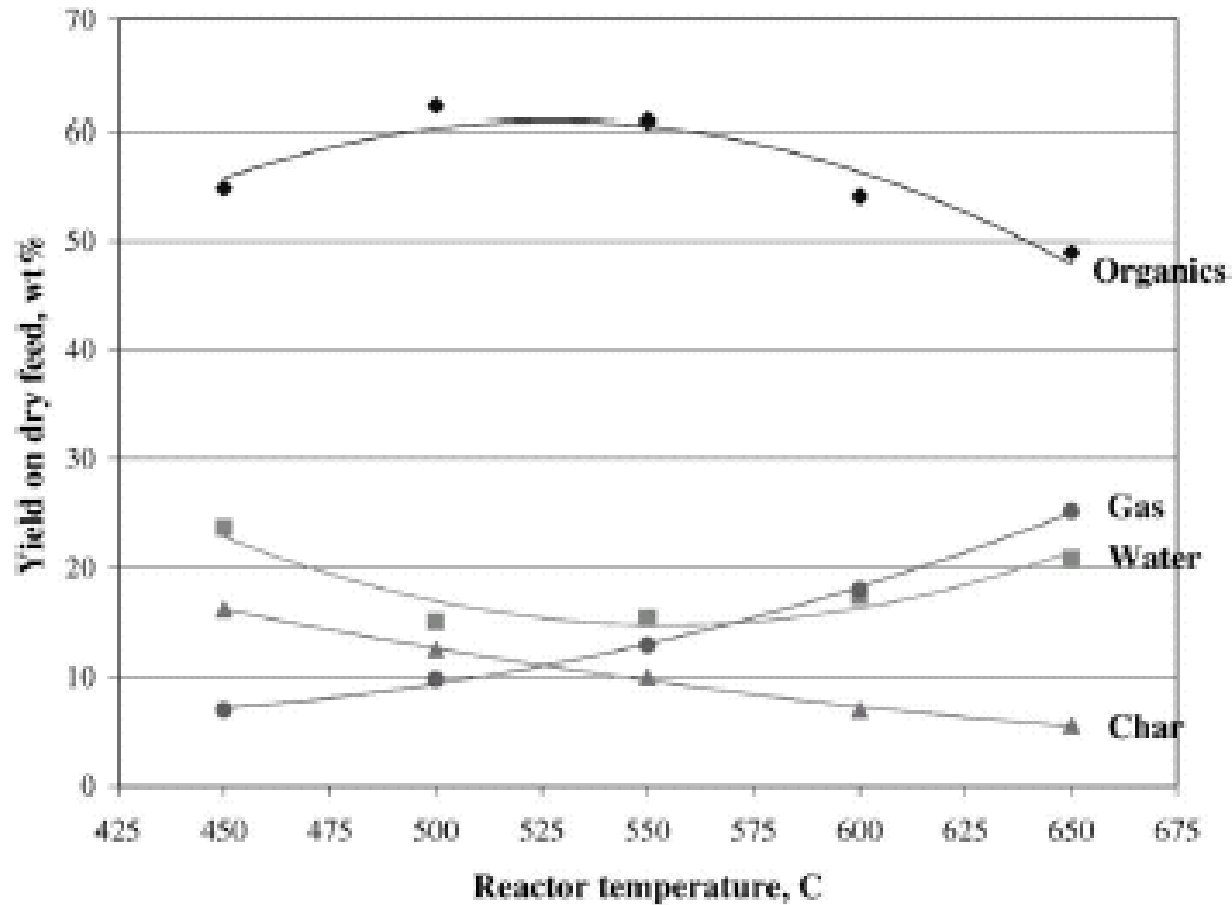

Pyrolysis (2/6)

The following factors play a significant role in the process:

- kinetics of involved reactions
- Heat transfer
- Mass transfer

The crucial point is the transfer of biomass particles to the optimum temperature simultaneously minimizing their residence time at lower temperatures which favor the formation of carbonaceous residue.



Pyrolysis (3/6)

Product yields for various pyrolysis methods:

	% wt.	solids	liquids	gasses
Fast pyrolysis		12	75	13
carbonization		35	30	35
Gasification		10	5	85



Pyrolysis (4/6)

During fast pyrolysis a mixture of vapours and aerosols and minor quantities of solid residues are formed.

After cooling a dark, low viscosity liquid is produced, which has half the LHV of conventional Diesel.



Pyrolysis (5/6)

The characteristics of this process are :

- High heating and heat transfer rates (biomass is fed in fine particles).
 - The operation temperature should be carefully selected (about 500 oC at the zone of solids, and 400 – 450 oC at the zone of gasses).
- Low residence time for gasses (lower than 2 sec).
- Rapid cooling of vapors to bio-oil.
- Bio-oil yields over 75 % wt, compared to dry feed.



Pyrolysis (6/6)

Fast pyrolysis presupposes that:

- the feed should be dried at water contents lower than 10 %, in order to minimize water concentration at bio-oil (acceptable limit 15 % H₂O in the final product).
- ground feed to particles smaller than 2 mm.

And includes the following steps:

- reaction (pyrolysis),
 - separation of solids,
 - collection of liquids,
- and refer to all biomass types.



Reactors (1-4)

- The pyrolysis reactor is the “heart” of the process.
- Consists 10 -15 % of the installation cost.
- The process also involves the storage of biomass its drying and grinding and the capture, storage and upgrading of products.



Reactors (2-4)

Fluidized bed

Simple construction and operation.
Adequate temperature control.
Efficient heat transfer.
Mature technology.
Liquids yield 70 – 75 %.
Adequate control of residence time.
Scale up.

disadvantages

Recycled Fluidized Bed

Adequate temperature control.
Efficient removal of solids due to higher flows.
Mature technology.
Similar residence times for gasses and solids.
Complex fluid dynamics.
Scale up.

disadvantages



Reactors (3-4)

Mechanical compression:

Wall temperature lower than 600 oC.

Allows the use of bigger particles.

There is no need for a carrier gas,
Leading to low volume equipment.

disadvantages

The slow step is the transfer of heat to.
The reactor and not to biomass.

Kinetics are controlled by the contact
surface.

Complex design, scale up.



Reactors (4-4)

Plug flow

Simple technology.
Easy scale up.

disadvantages

Poor heat transfer.
Low yields and efficiencies.



Pilot Plants



**Pilot Plant
at California**

Pilot Plant at Canada



Pilot Plant at US



**Pilot Plant at Canada
15 tn /day**



**Industrial Plant
at Canada
100 tn /day**



Removal of solids

- Solid byproducts are vapor cracking catalysts and their fast removal is crucial for the efficiency.
- The removal is taking place in cyclones.
- **disadvantage:** fine particles end up to liquids decreasing their stability and accelerating their aging.
- High temperature filters produce a bio-oil free from solids.
- **disadvantage:** 10-20% decreased efficiency due to oil depositions.



Liquids collection

Pyrolysis gaseous products are consisted of:

aerosols (liquids in the gas stream),

vapors (condensable gasses),

gasses that are not condensating at environmental conditions,

and require rapid cooling in order to avoid further reactions and gasification.

Simple cooling leads to the selective deposition of liquid macromolecules and as a result bio-oil composition is influenced while there is an increased possibility for fouling.



Liquid products

- The liquid product of pyrolysis is named biooil or pyrolysis oil, crude biooil, etc.
- Has a dark brown color and similar chemical composition with biomass.
- Is essentially a complex mixture of various organic compounds and water, which is originated from biomass and the chemical reactions taking place during pyrolysis.
- Probably is also including solid carbonaceous residue and dissolved alkalis.



Bio-oil chemical characteristics (1/3)

It can be considered as emulsion:

- the continuous phase is a solution of cellulose decomposition derived products,
- the non-continuous phase is consisted from macromolecules derived from the decomposition of lignin,
- the first phase stabilize the second one through hydrogen bonds,
- bio-oil aging is attributed to the gradual break of these bonds.



Bio-oil chemical characteristics (2/3)

Typical composition of bio-oil:

Hydrocarbons	10 – 15 %
Phenols	15 – 20 %
Acids / esters	5 – 10 %
Alcohols	10 – 15 %
Furans	10 -15 %
Carbonyls	10 – 15 %
Lignin derivatives	15 -20 %
Water	up to 15 %



Bio-oil chemical characteristics (3/3)

pH: 2,5

Specific weight: 1,2 gr/cm³

Elemental analysis:

C 55 – 58 %

H 5 – 7 %

O 35 – 40 %

HHV: 16 -19 MJ/kg

water up to 25 % (40 % of diesel HHV).



Bio-oil applications (1/2)

As a substitute of common diesel in stationary applications:

burners – boilers,
furnaces,
internal combustion engines,
turbines.

Its upgrading (hydrogenation) to transport fuels is feasible;
however has negative profits.



Bio-oil applications (2/2)

Till today, bio-oil has been used in:

Modified ICE up to 250kWe.

Gas turbines up to 2.5MWe.

Chemicals Production:

Resins

additives.

Pesticides

sweeteners.

Fertilizers

preservatives.



Current status

Product: 10 - 100 % more expensive than diesel (Heating value based).

Low production capacity.

Absence of quality standards

Incompatible with existing fuels.

Storage / management.

Crucial Factors: Scale up.

Minimize cost of production.

Constant characteristics.

Health and safety when handling.



Feasibility of biomass thermochemical conversion methods (1/2)

Combustion	(Combust).
Atmospheric Gasification	(GasEng).
Combined cycle	(IGCC) .
Fast Pyrolysis	(PyrEng).

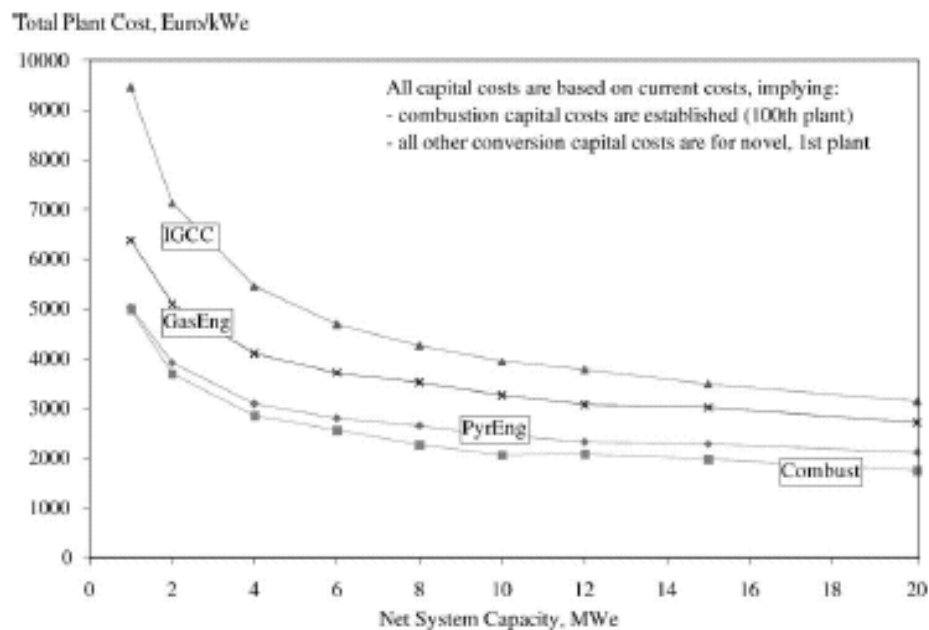

Fig. 14. Comparison of total plant costs for four biomass to electricity systems.



Feasibility of biomass thermochemical conversion methods (2/2)

Electricity Production Cost, Euro/kWh * 100

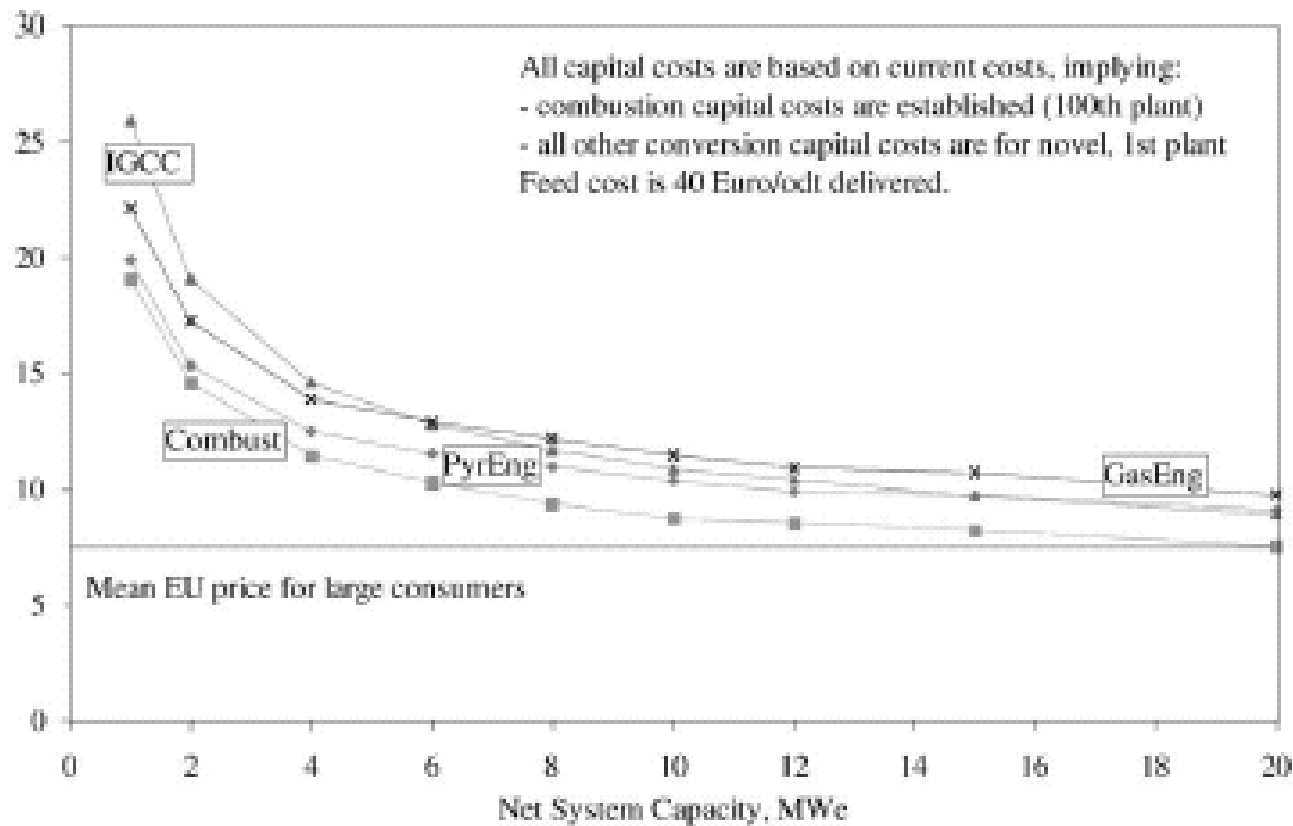

Fig. 15. Comparison of electricity production costs for four biomass to electricity systems.



Biomass Energy Conversion Technologies

Pyrolysis:

Bio-oil Overall Efficiency:
60 – 70 % of biomass LHV is transferred in liquids.

It is not yet a commercial technology.

Pyrolysis is considered mainly as a pretreatment step of solid biomass in cases where biomass is needed to be transferred in long distances.

Bio-oil can be used as a raw material for the production of high added value chemicals.



Biomass Pyrolysis Pilot Plant



Bio-oil Samples



Τέλος Ενότητας



Ευρωπαϊκή Ένωση
Ευρωπαϊκό Κοινωνικό Ταμείο

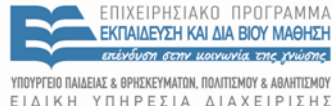

Με τη συγχρηματοδότηση της Ελλάδας και της Ευρωπαϊκής Ένωσης

