

ΠΑΝΕΠΙΣΤΗΜΙΟ ΔΥΤΙΚΗΣ ΜΑΚΕΔΟΝΙΑΣ
ΤΜΗΜΑ ΕΙΚΑΣΤΙΚΩΝ ΚΑΙ
ΕΦΑΡΜΟΣΜΕΝΩΝ ΤΕΧΝΩΝ

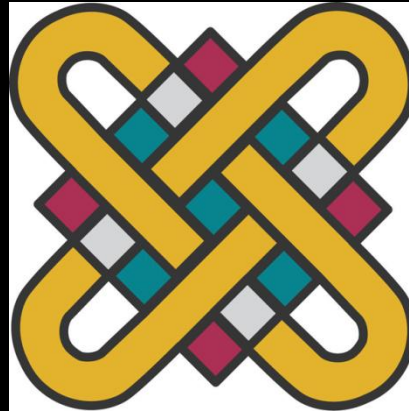

1^ο Εργαστήριο Ζωγραφικής
Κύκλος
Εννοιολογικές Θεματικές
Γιάννης Ζιώγας
Επίκουρος Καθηγητής

Ισορροπία

ΙΣΟΡΡΟΠΙΑ



ΣΥΜΜΕΤΡΙΑ

*Στατική
ισορροπία*

ΑΣΥΜΜΕΤΡΙΑ

*Δυναμική
ισορροπία*

ΙΣΟΡΡΟΠΙΑ

Η ισότητα μεταξύ έλξεως και αντιστάσεως

(Της γής αυτής την ισορροπίαν - ισορροπία έλξεως και αντιστάσεως. Πλάτ. Φαίδ. 109A)

ΙΣΟΡΡΟΠΙΑ

Συμμετρία

Η ιδιότης του σύμμετρου ή συμμετρικού, αρμονία λόγω κανονικών αναλογιών, που αποτελεί ένα από τους χαρακτήρες του καλού και αγαθού.

(Βίου συμμετρίη, η νυκτός προς ημέρα συμμετρία)

Ασυμμετρία

Η έλλειψις συμμετρίας, αναλογίας, αρμονίας, η δυσαναλογία
(ασυμμετρίας και αισχροτήτας γέμουσαν ψυχήν)

Handwritten text in a cursive script, likely a preface or introduction to the drawing, located at the top of the page.

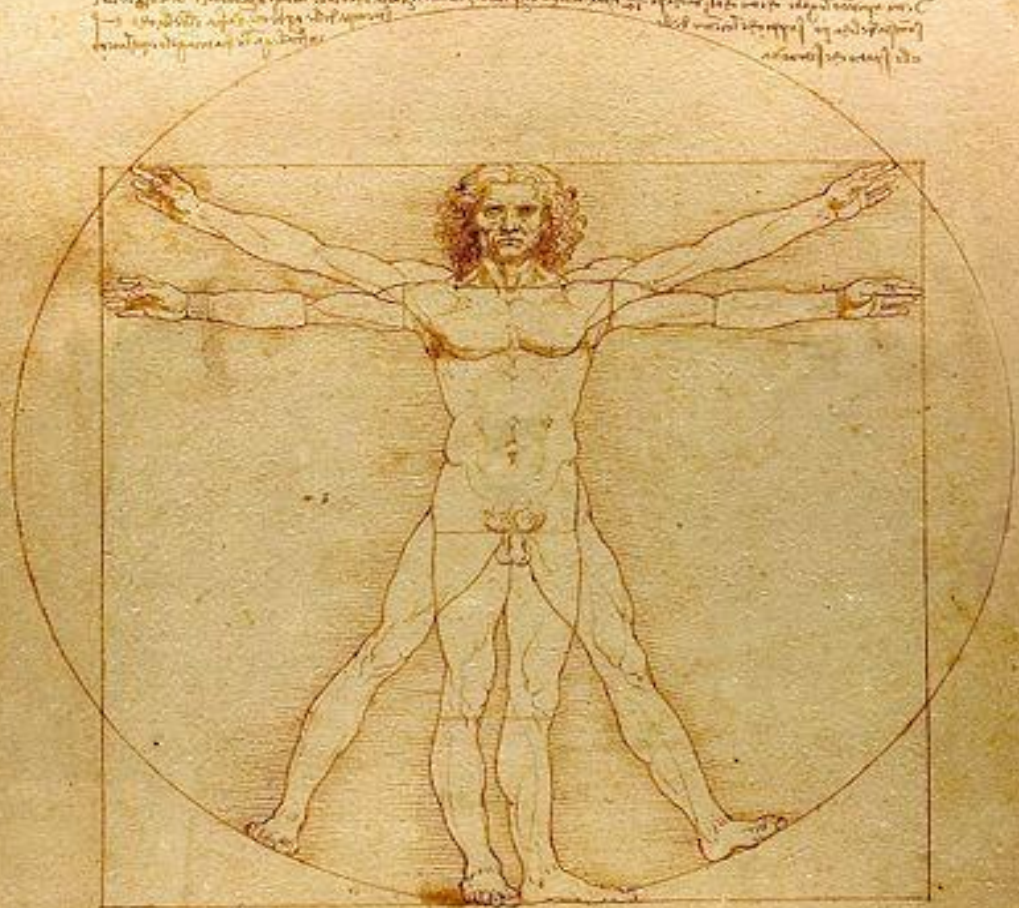

Handwritten text located below the drawing, possibly providing measurements or further commentary on the proportions shown.

Handwritten text at the bottom of the page, continuing the notes or commentary related to the drawing.

Handwritten text in the bottom right corner, possibly a signature or date.



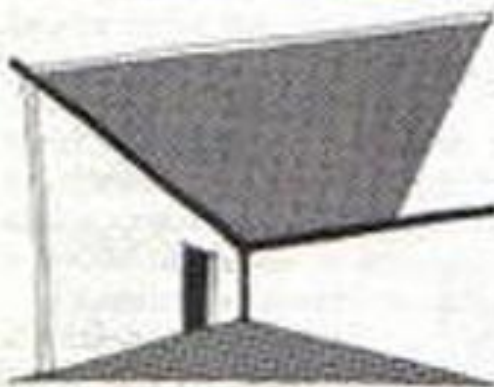
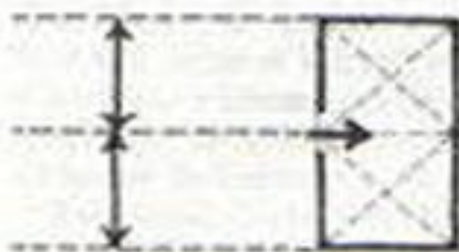
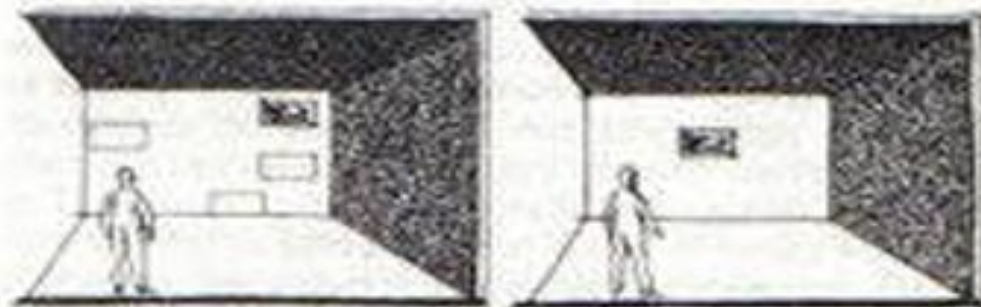



Esc. 2017



Losmas + Jarama

Non-symmetrical balance.

(Symbol):

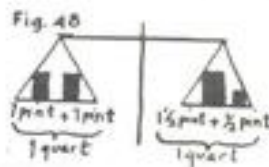

Disturbed
Balance

Restored
Balance

a) Metric:



b) Weight:



c) Character:

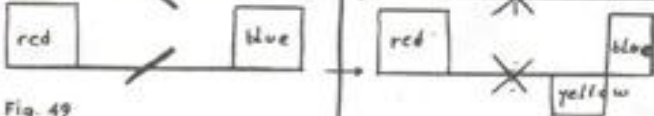

Fig. 49

ΜΕΡΙΚΕΣ ΑΝΤΙΘΕΤΙΚΕΣ ΣΧΕΣΕΙΣ

Φως
Άδειο
Πλακάτο
Τριδιάστατο
Διδιάστατο
Γραμμικό
Αφαιρετικό
Στατικό
Συμμετρικό
Καθαρό χρώμα

Σκιά
Γεμάτο
Χειρονομιακό
Διδιάστατο
Γραμμικό
Τρισδιάστατο
Περιγραφικό
Ενεργητικό
Ασύμμετρο
Εξουδετερωμένο χρώμα



Will Alshop, Ontario Art School, 2004

ΣΥΜΜΕΤΡΙΑ

Η ισορροπία των ίσων

Στατικότητα

Το κενό συνοδεύει

Οι κάθετοι άξονες στηρίζουν

Οι τονικότητες και τα χρώματα απλώνονται παντού ισοδύναμα

Κυκλαδικός πολιτισμός,
Κλασικισμός, Αναγέννηση
(Ιταλική και Φλαμανδική),
Νεοκλασικισμός,
Μινιμαλιστική Τέχνη

Φειδίας, Ουτσέλλο, Τιτσιάνο,
Πουσέν, Εγκρ, Σερά, Σεζάν,
Τζάντ, Μόραλης, Μοντριάν,
Αγκνες Μάρτιν

ΑΣΥΜΜΕΤΡΙΑ

Η εξουδετέρωση των αντιθέτων

Κινητικότητα

Το κενό ενεργοποιείται

Οι διαγώνιοι άξονες πιέζουν

Οι τονικότητες και τα χρώματα περικλείονται σε συγκεκριμένες περιοχές

Ελληνιστική περίοδος, Μπαρόκ,
Ρομαντισμός, Φωβισμός,
Εξπρεσιονισμός

Σκόπας, Μιχαήλ Άγγελος,
Καραβάτζιο, Ντελακρουά,
Βαν Γκόγκ, Μπουζιάνης, Σήλε,
Άουερμπαχ,

Χρυσή Τομή

**Η χρυσή τομή είναι ο μέσος χώρος
μεταξύ συμμετρίας και
ασυμμετρίας**

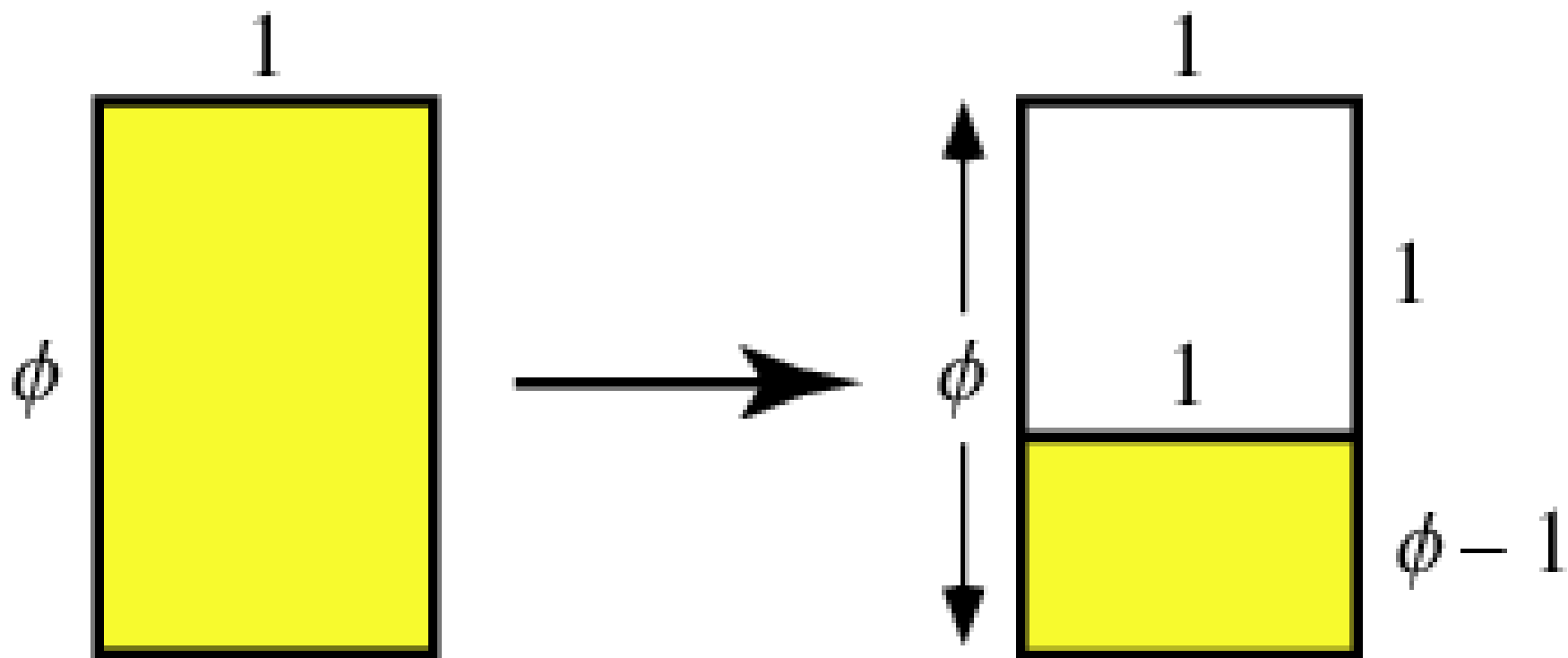

$$\phi = \frac{AC}{CB} = \frac{AB}{AC}$$

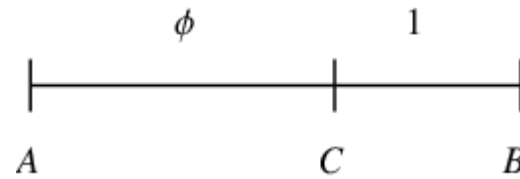

1.618033988749894848204586834365638117720 ...

$$\frac{1}{2} \left(1 + \sqrt{5} \right)$$

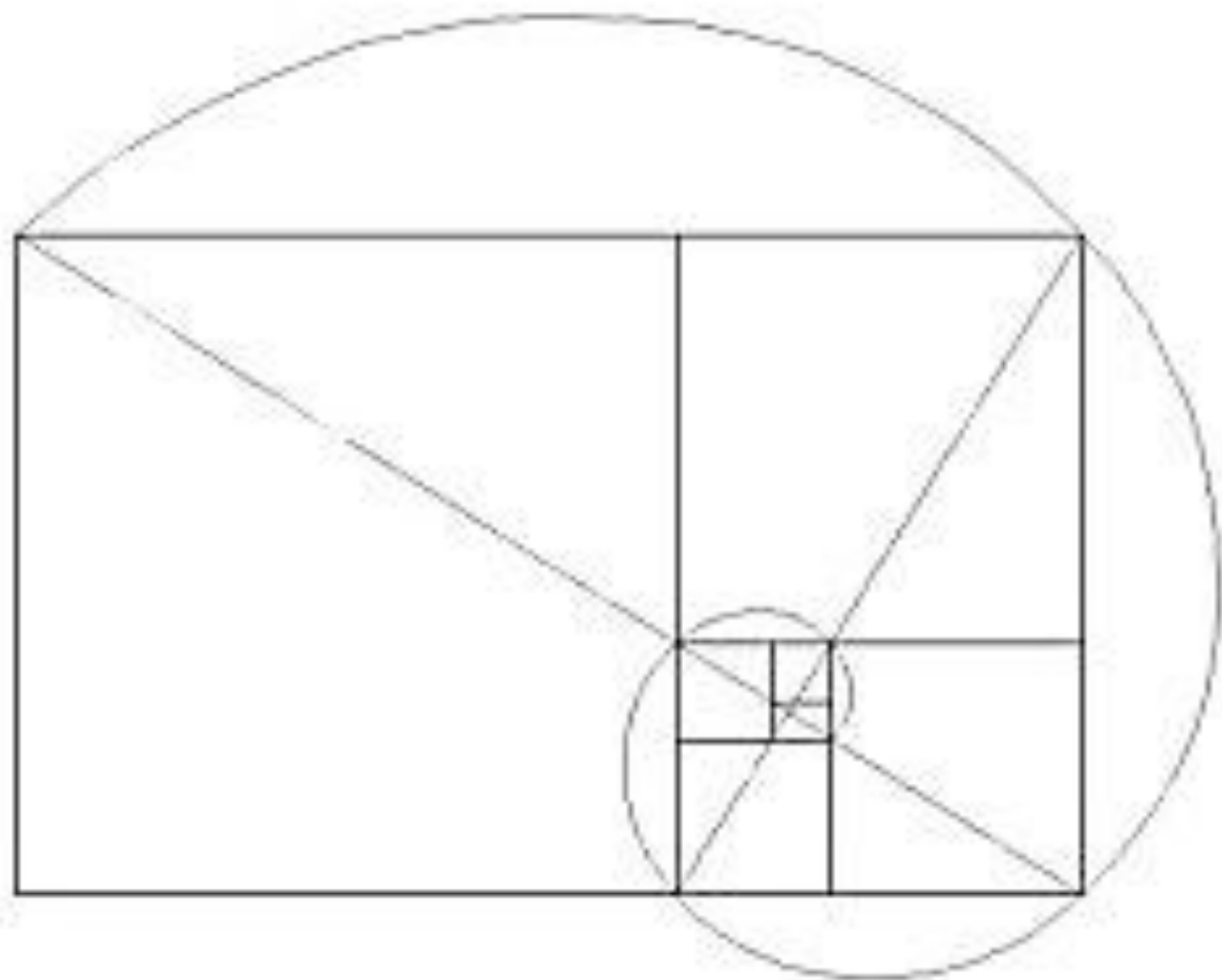

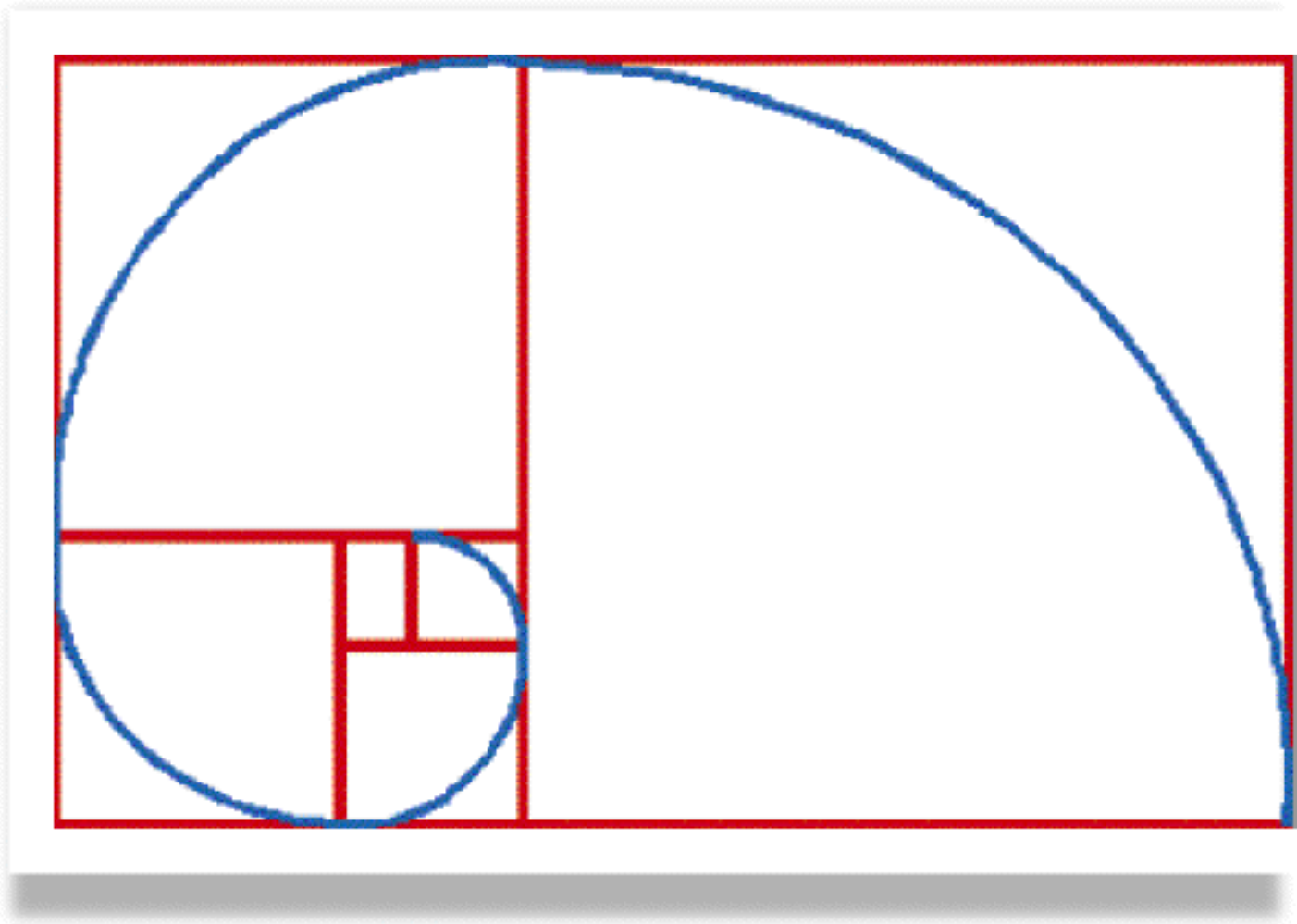

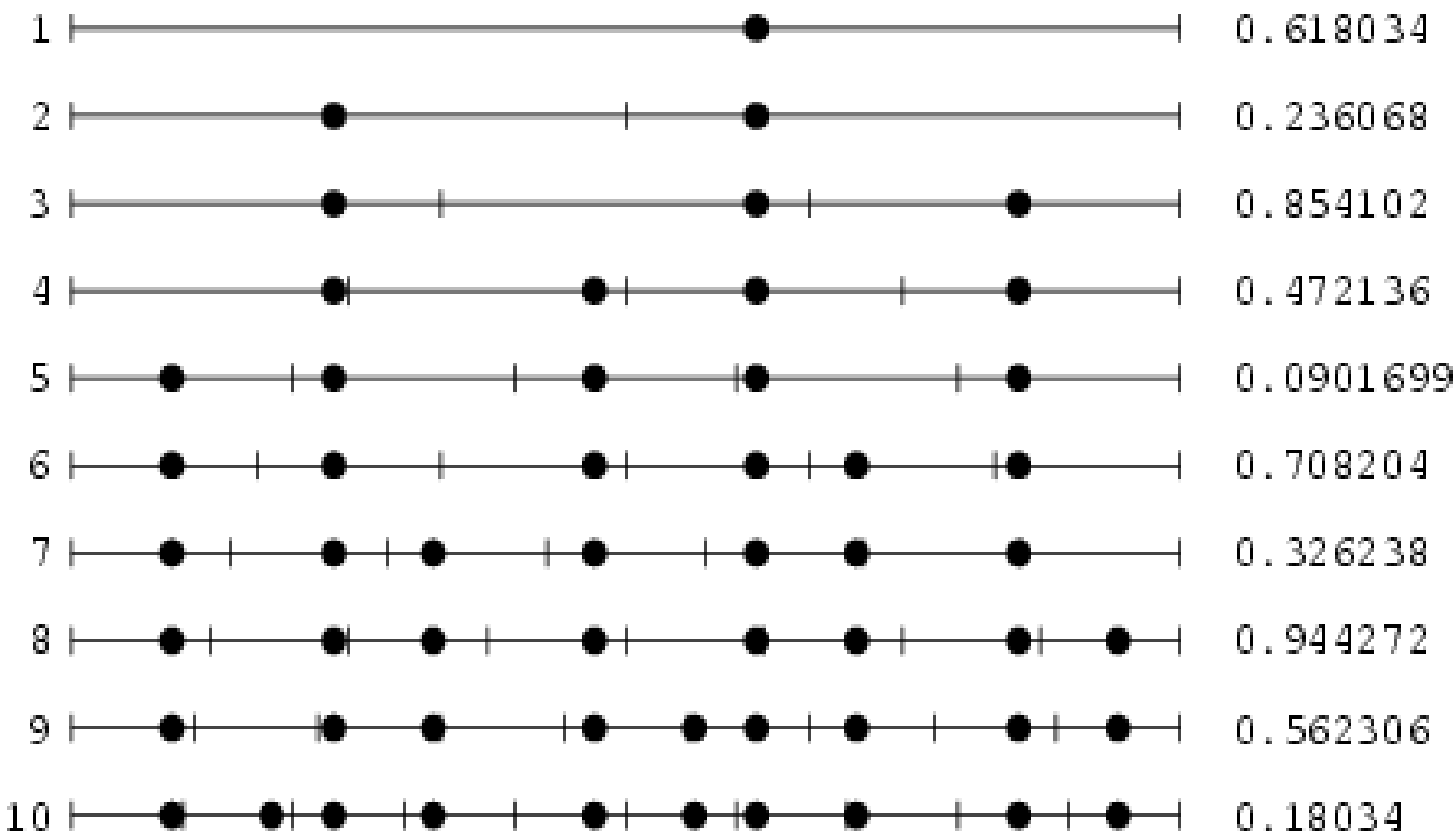

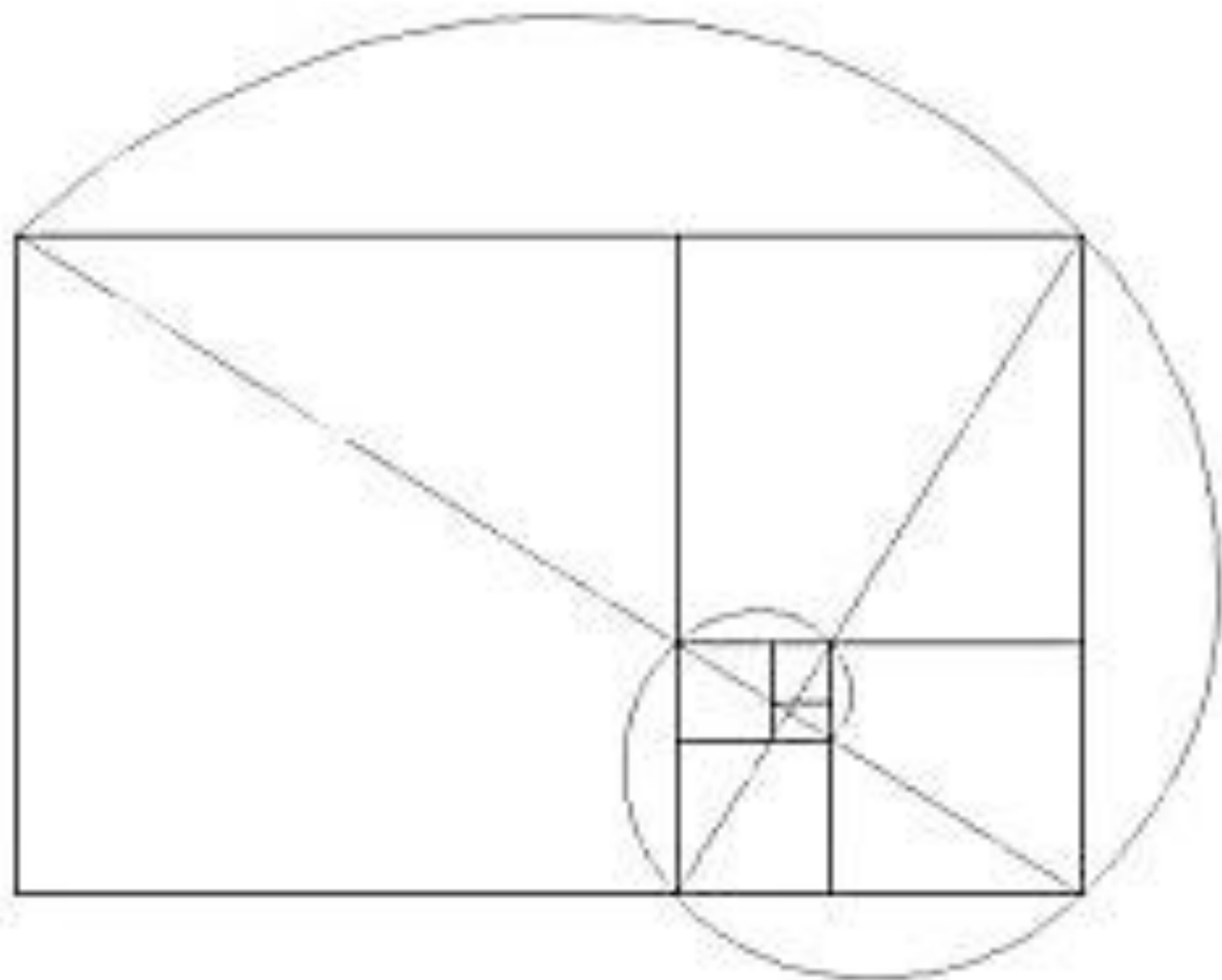

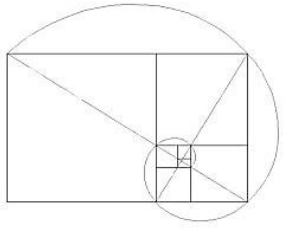

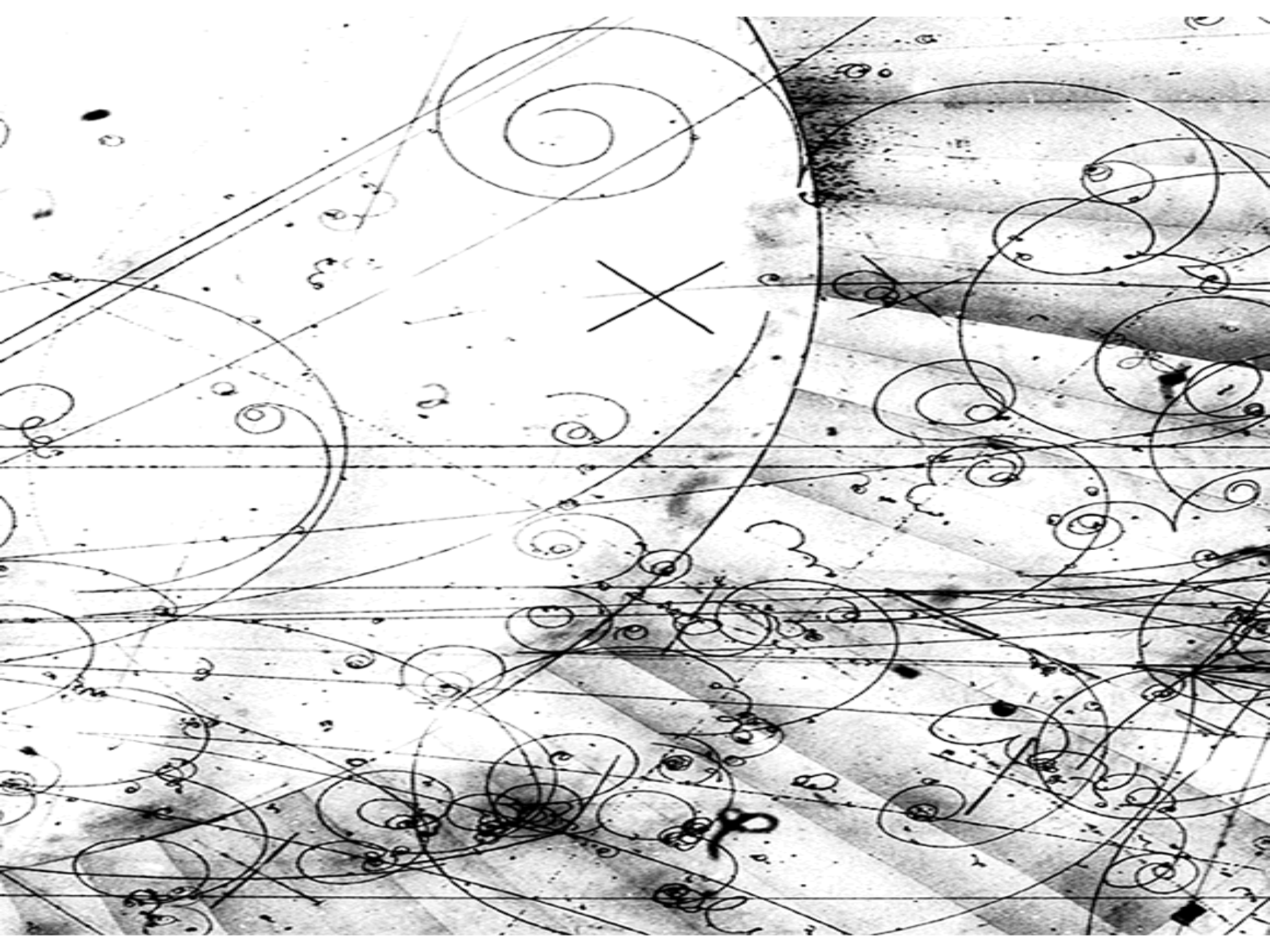



My new Hypothesis: If we're built from Spirals while living in a giant Spiral, then is it possible that everything we put our hands to is infused with the Spiral?"

-- Max Cohen in the motion picture π



Χρυσή Τομή

**Η χρυσή τομή είναι ο μέσος χώρος μεταξύ
συμμετρίας και ασυμμετρίας**

ΙΣΟΡΡΟΠΙΑ



ΣΥΜΜΕΤΡΙΑ

*Στατική
ισορροπία*

ΑΣΥΜΜΕΤΡΙΑ

*Δυναμική
ισορροπία*



boteh

an asymmetrical
motif

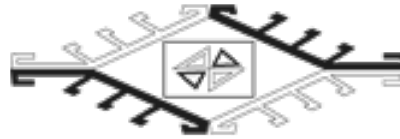

dyrnak gul

a symmetrical
motif

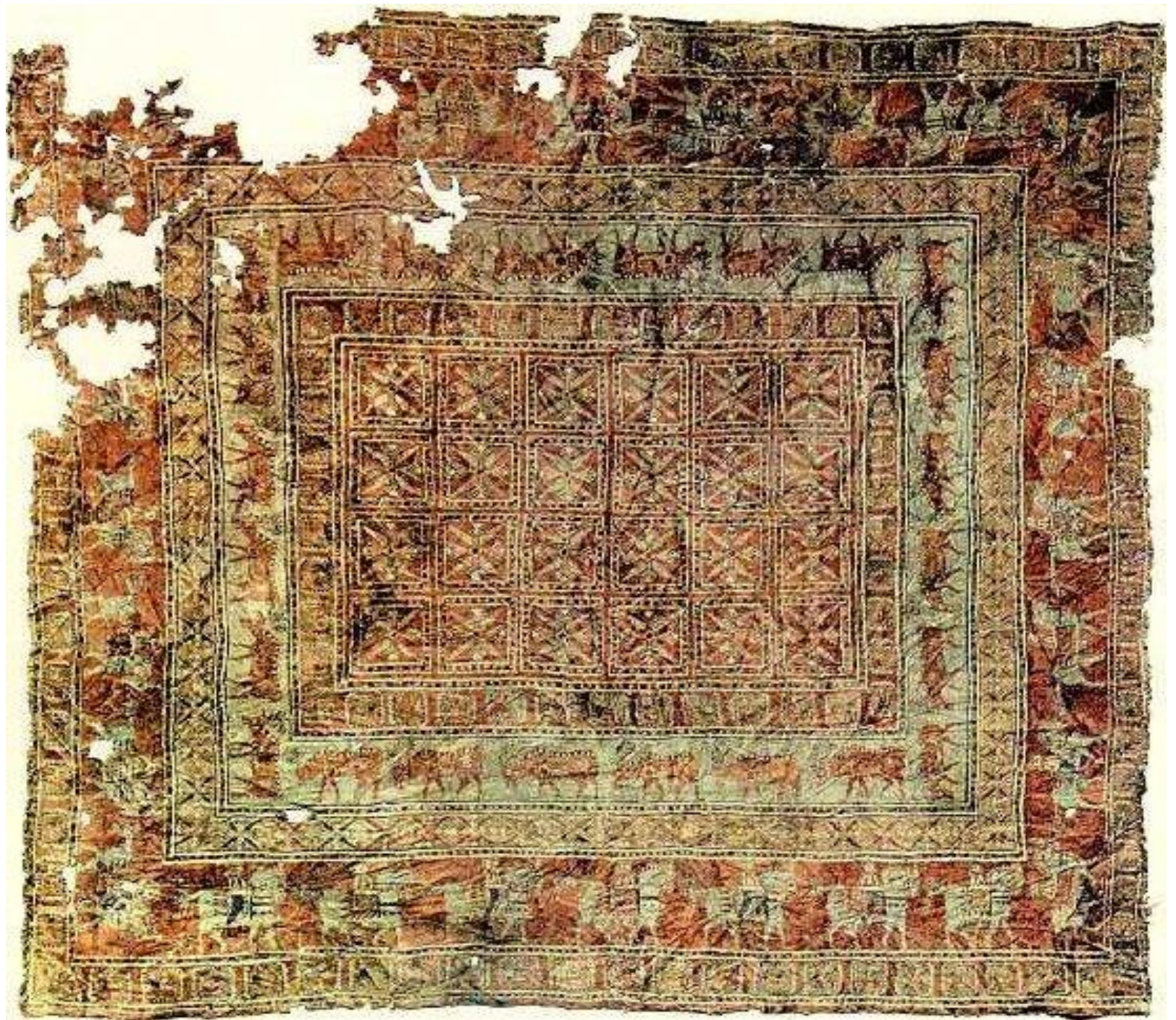





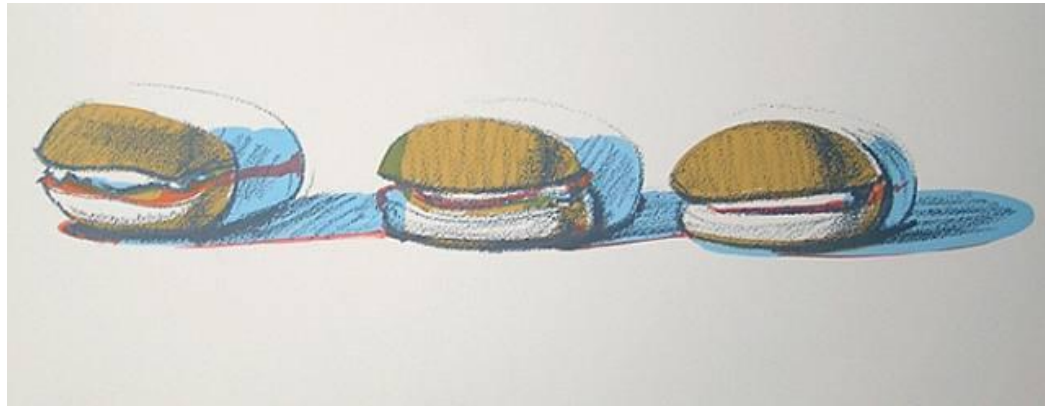



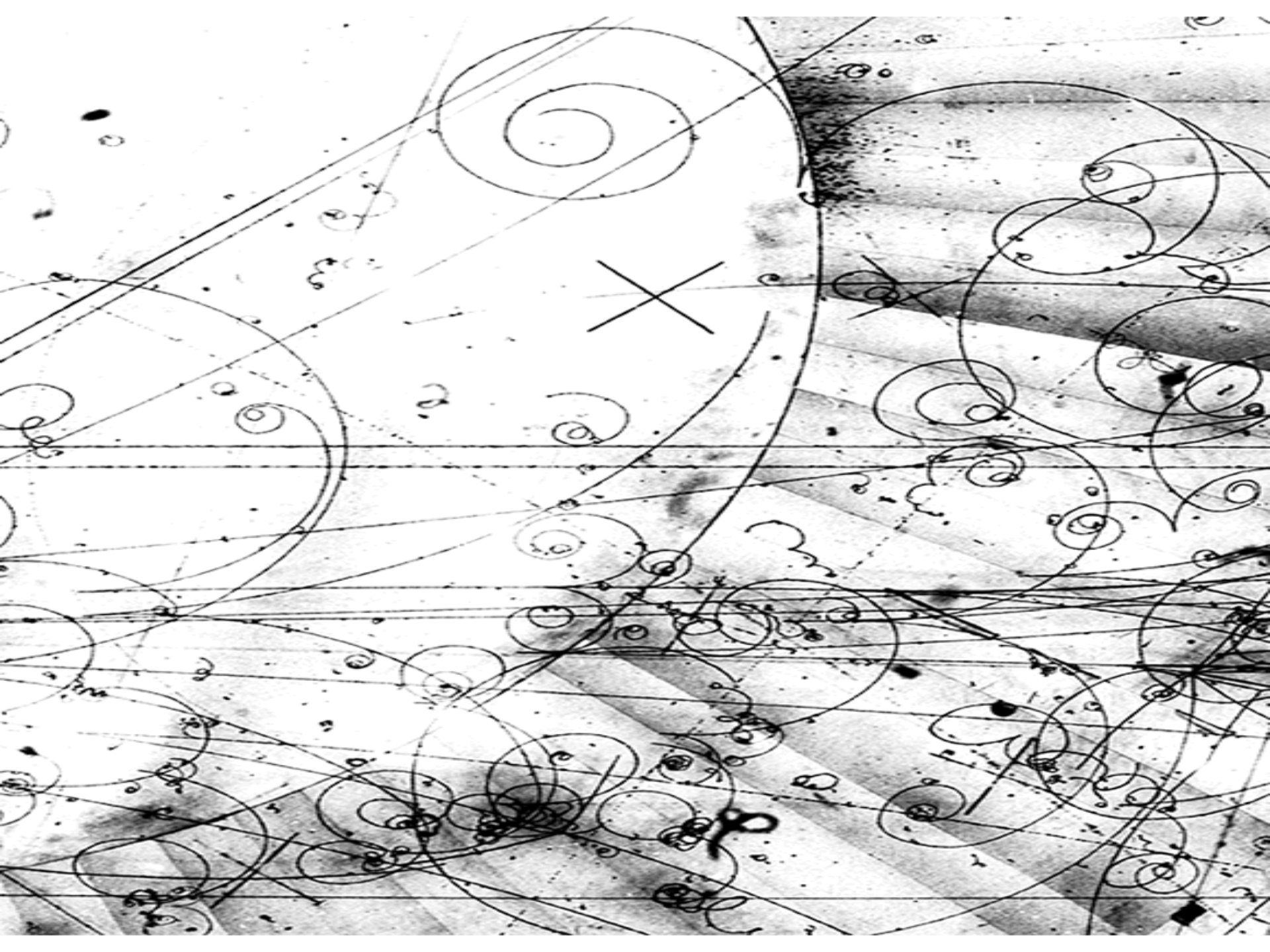



SLW

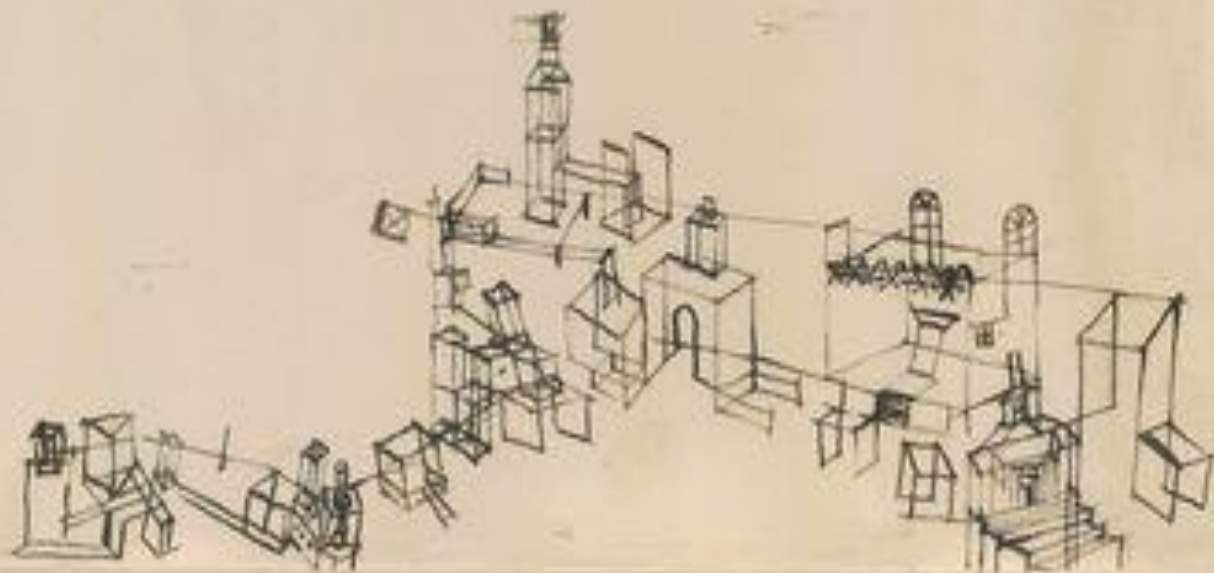

1872 - 1873

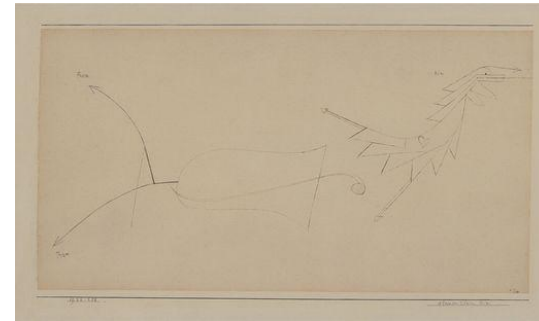
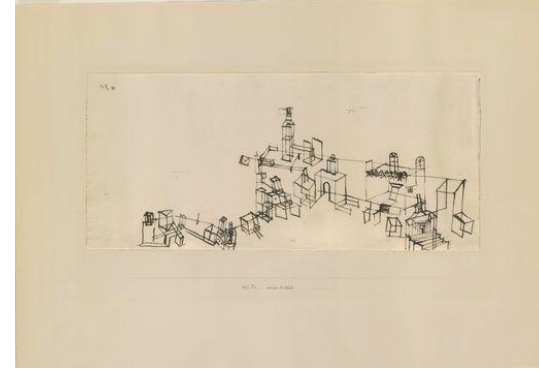
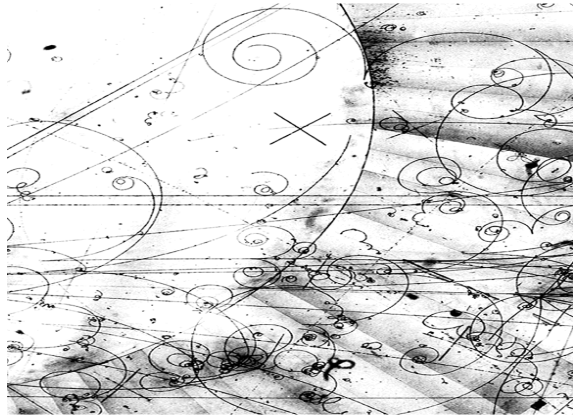

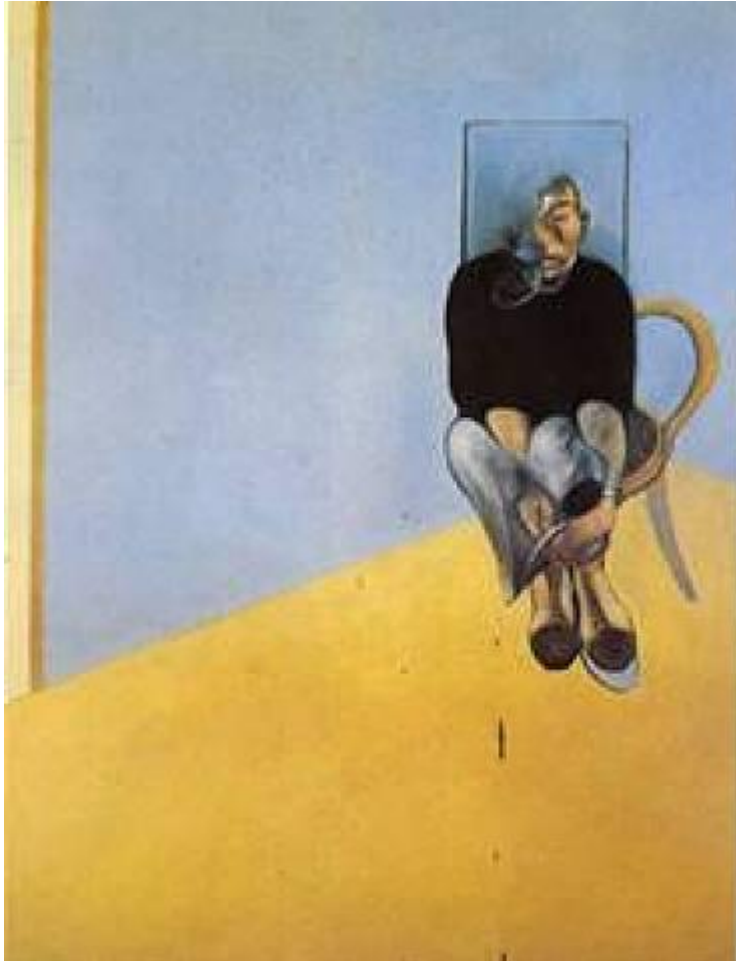

Στατική Ισορροπία



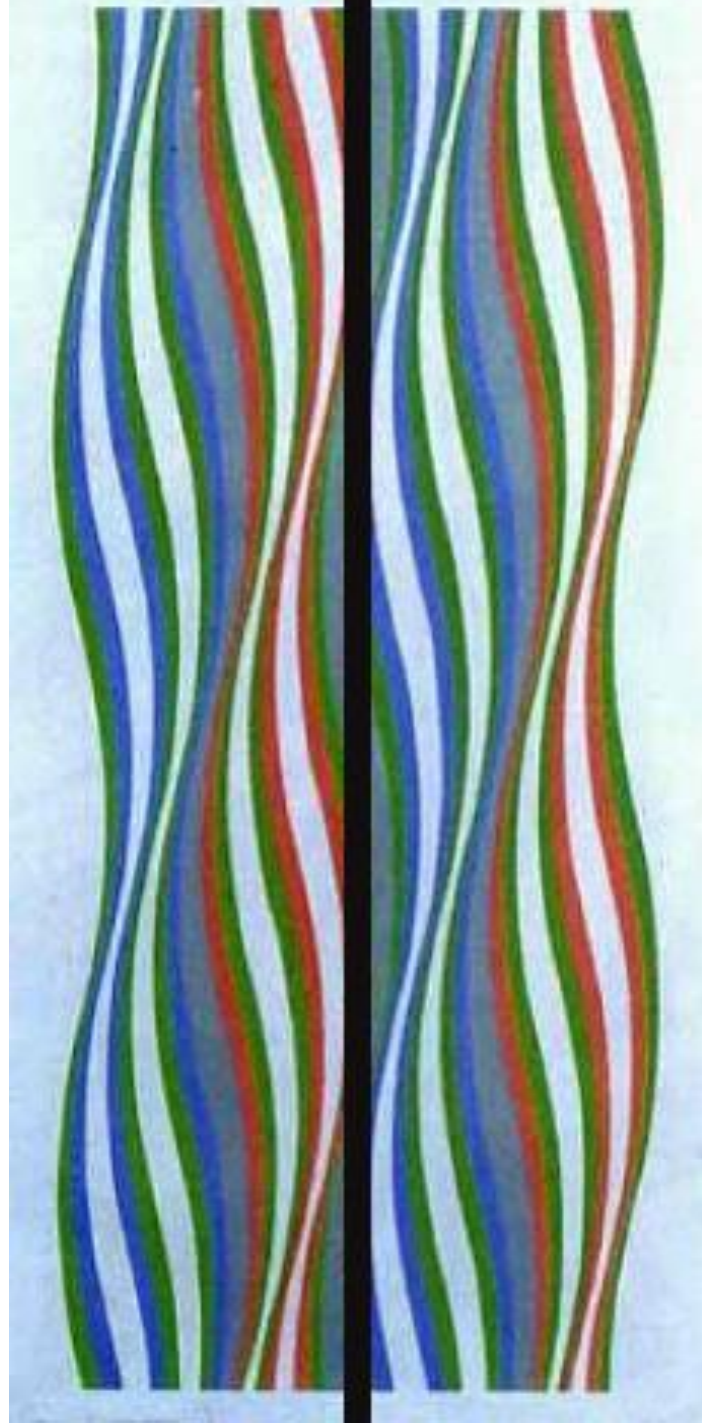

Οπτική Συμμετρία

VS

Γεωμετρική Συμμετρία



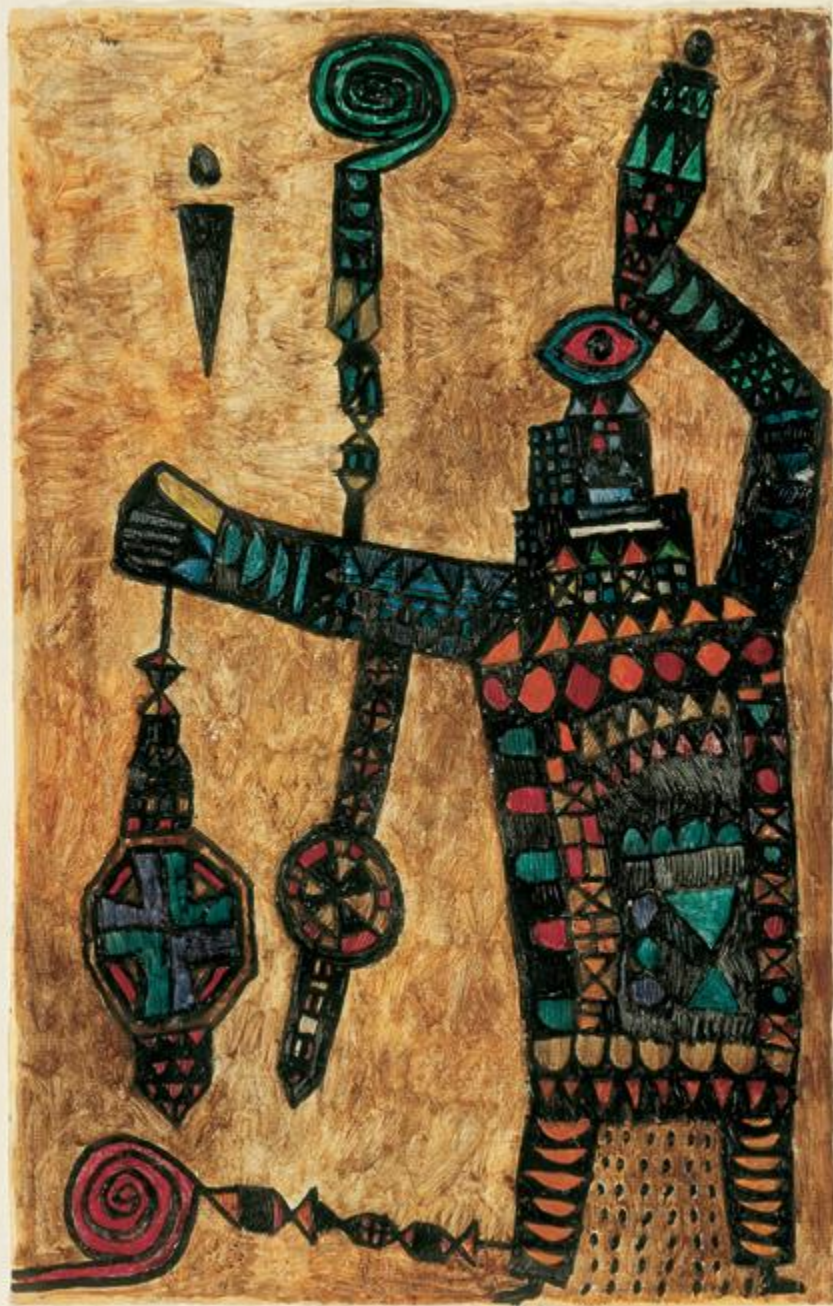



Δυναμική Ισορροπία

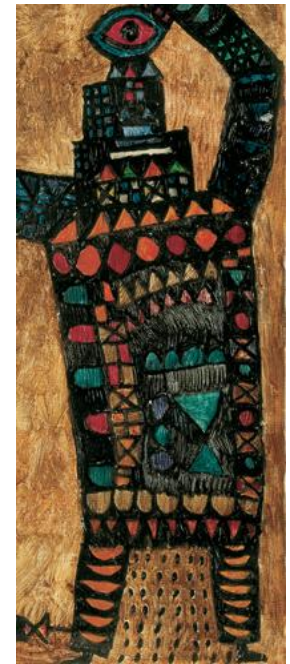

Das Scherz mit der Drogen
1922/23

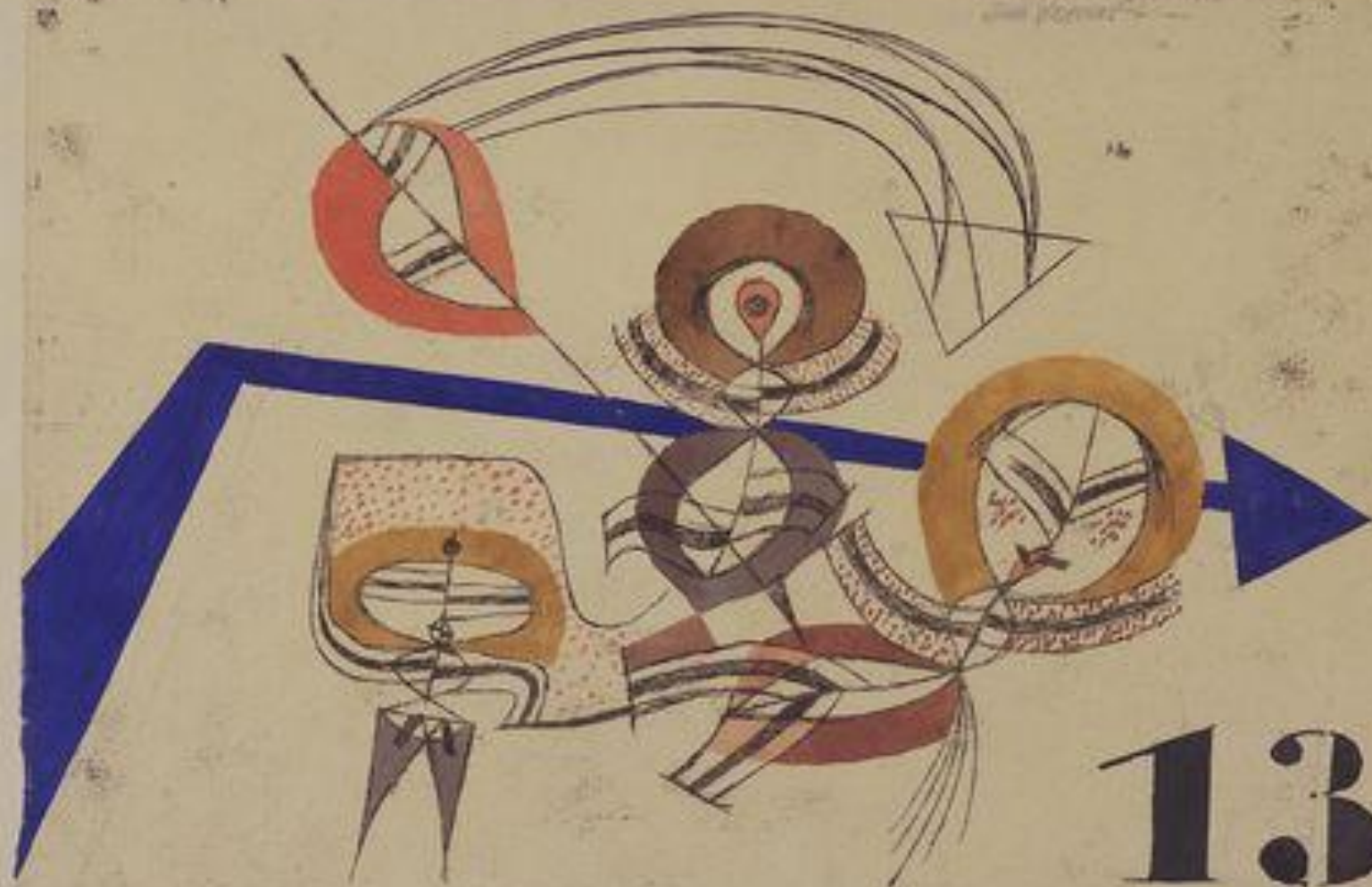

13

1922/23 Das Scherz mit der Drogen



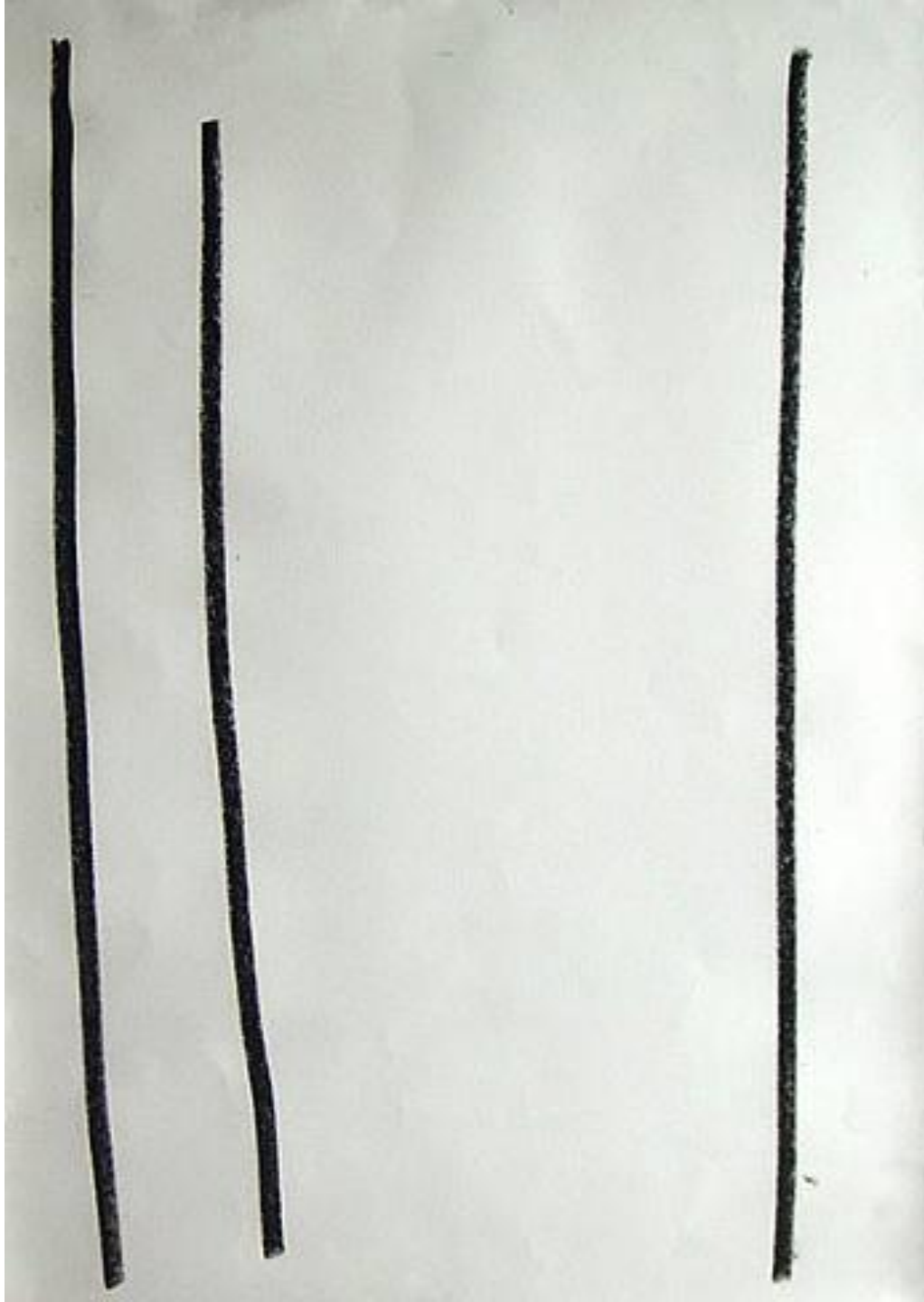

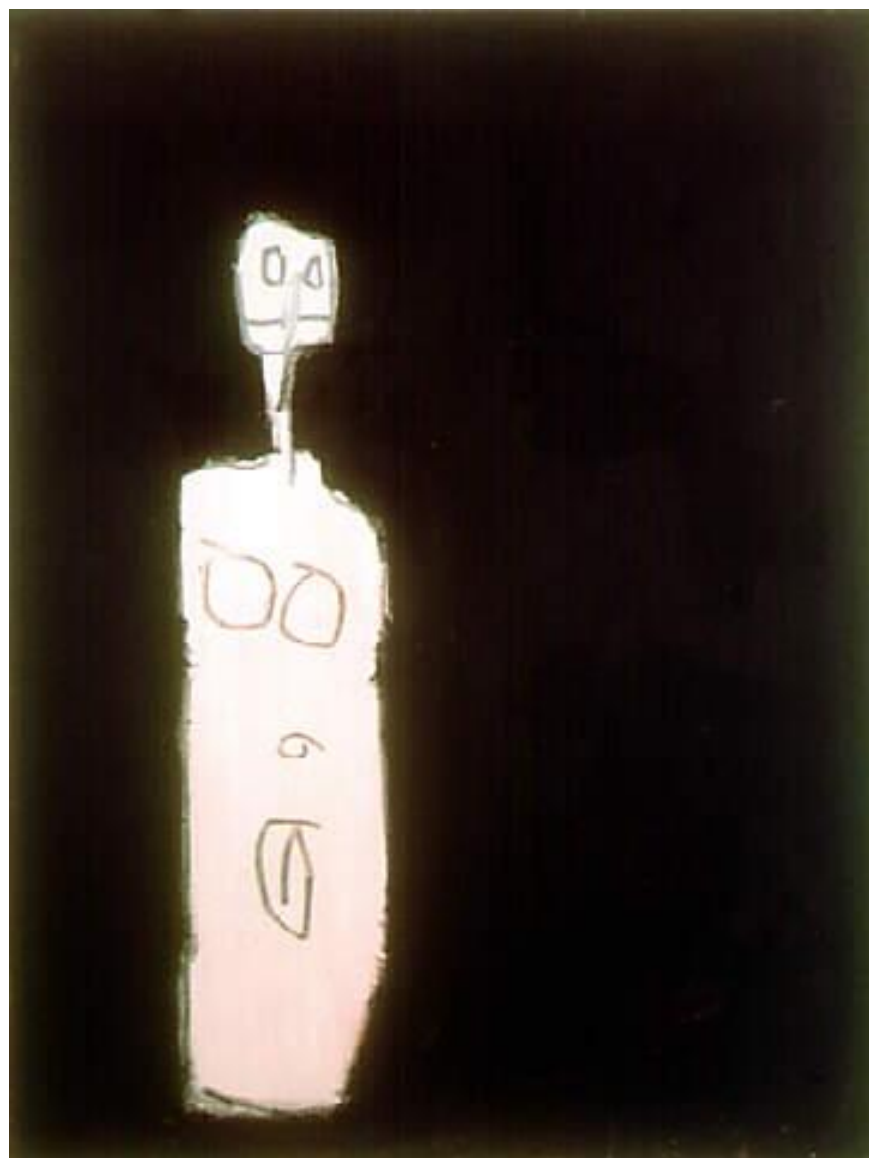

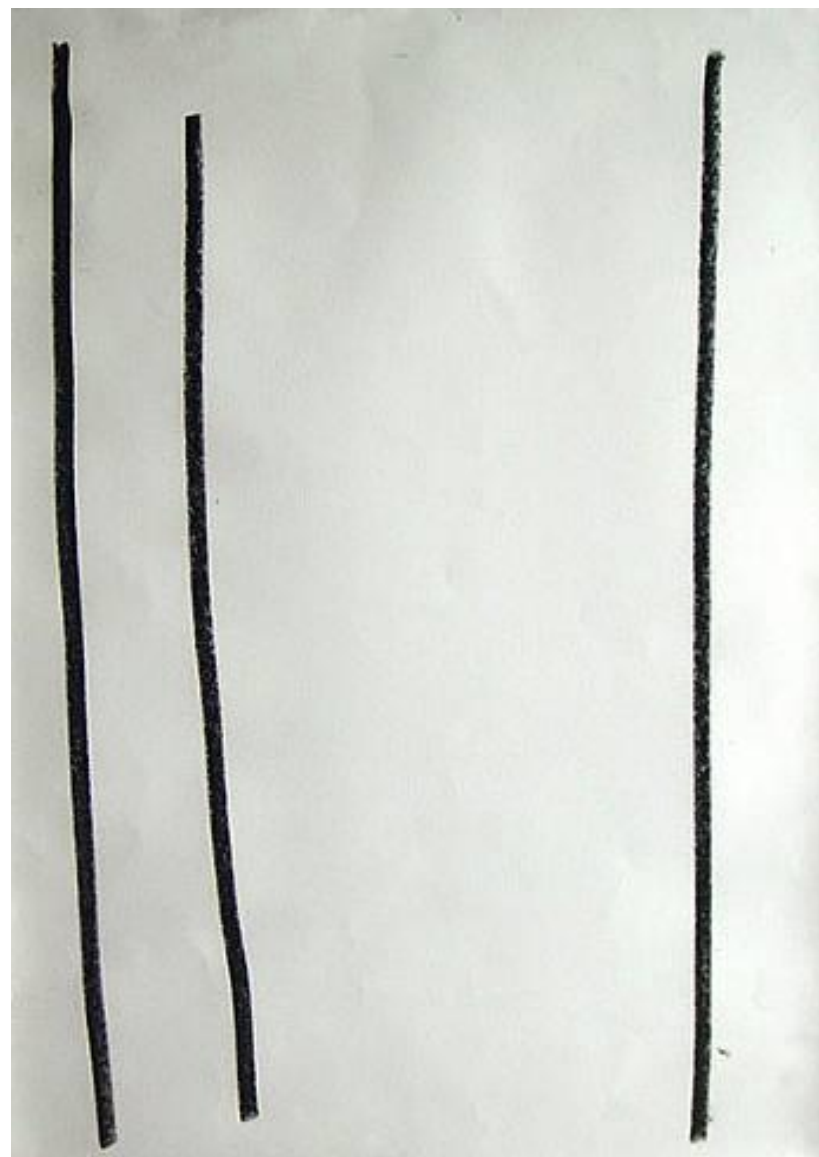
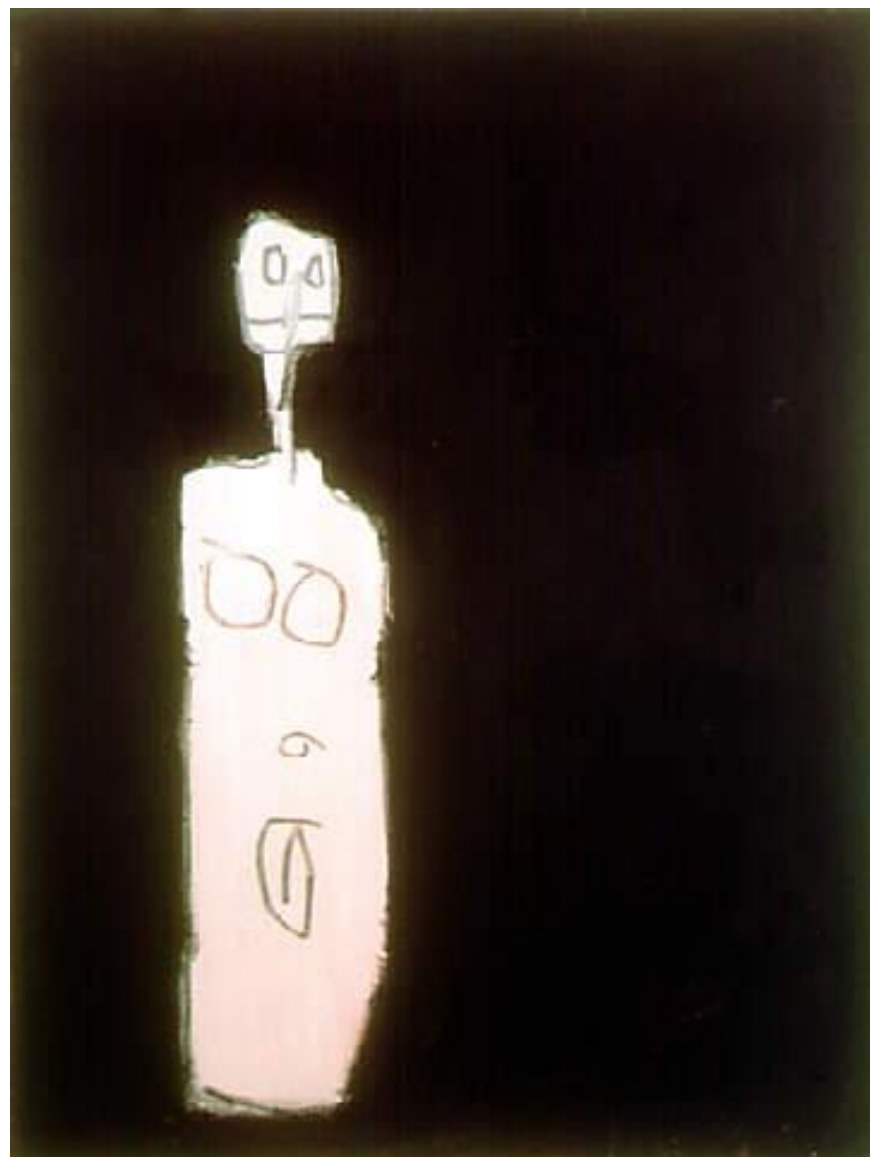

<http://gwydir.demon.co.uk/jo/symmetry/index.htm>

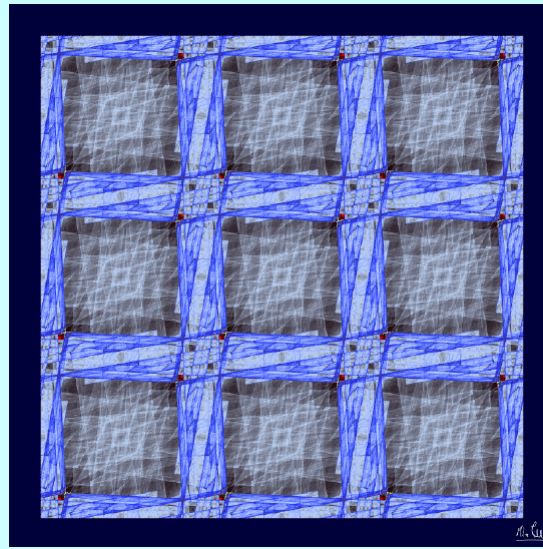
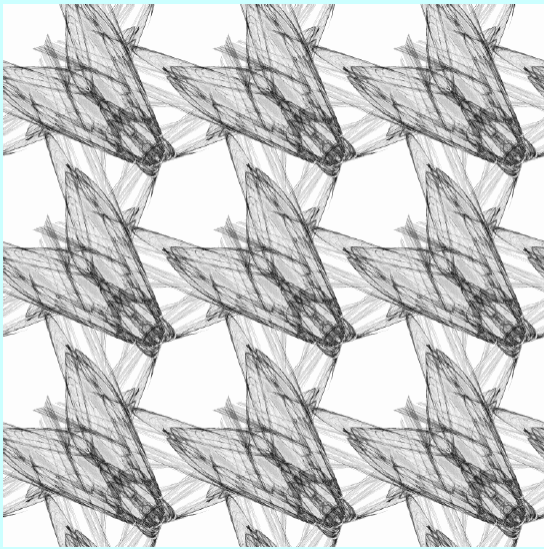

<http://nothung.math.uh.edu/~mike/ag/icons/thorns.jpg>



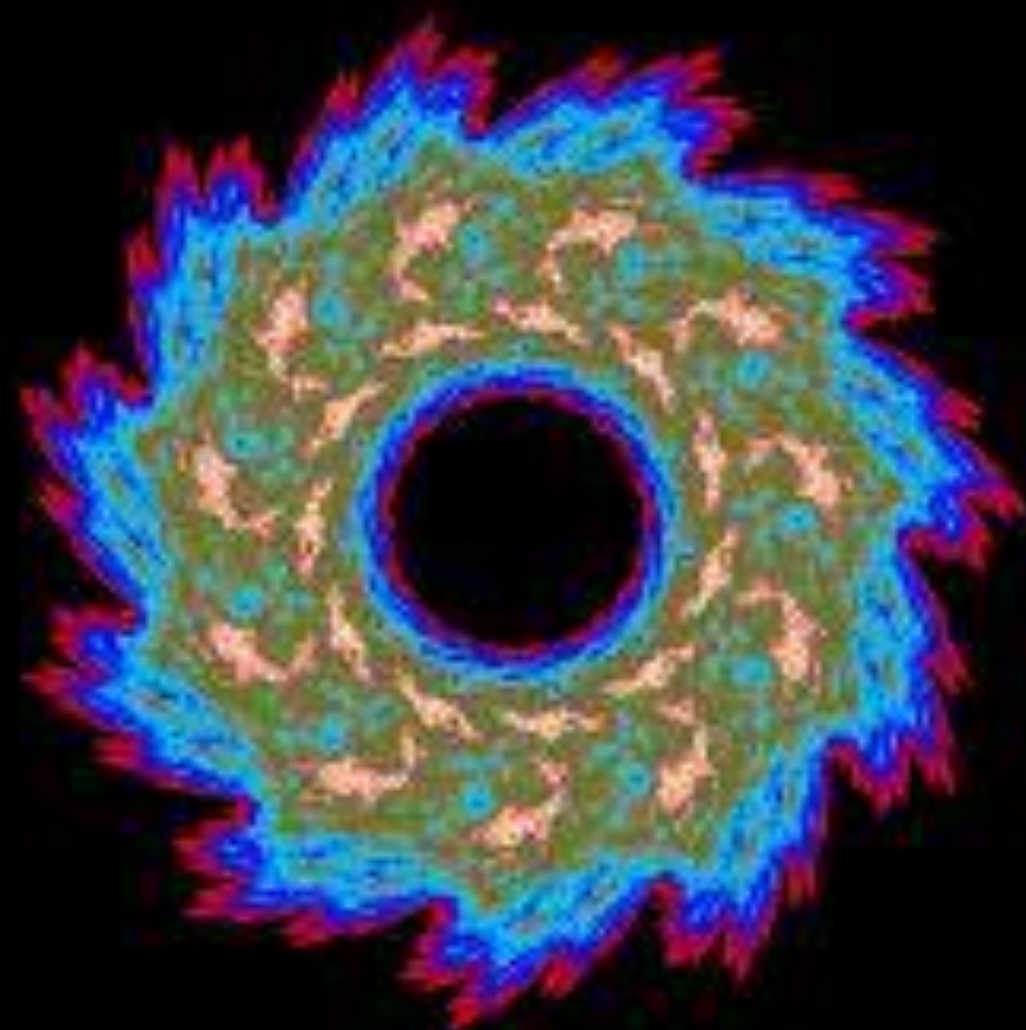

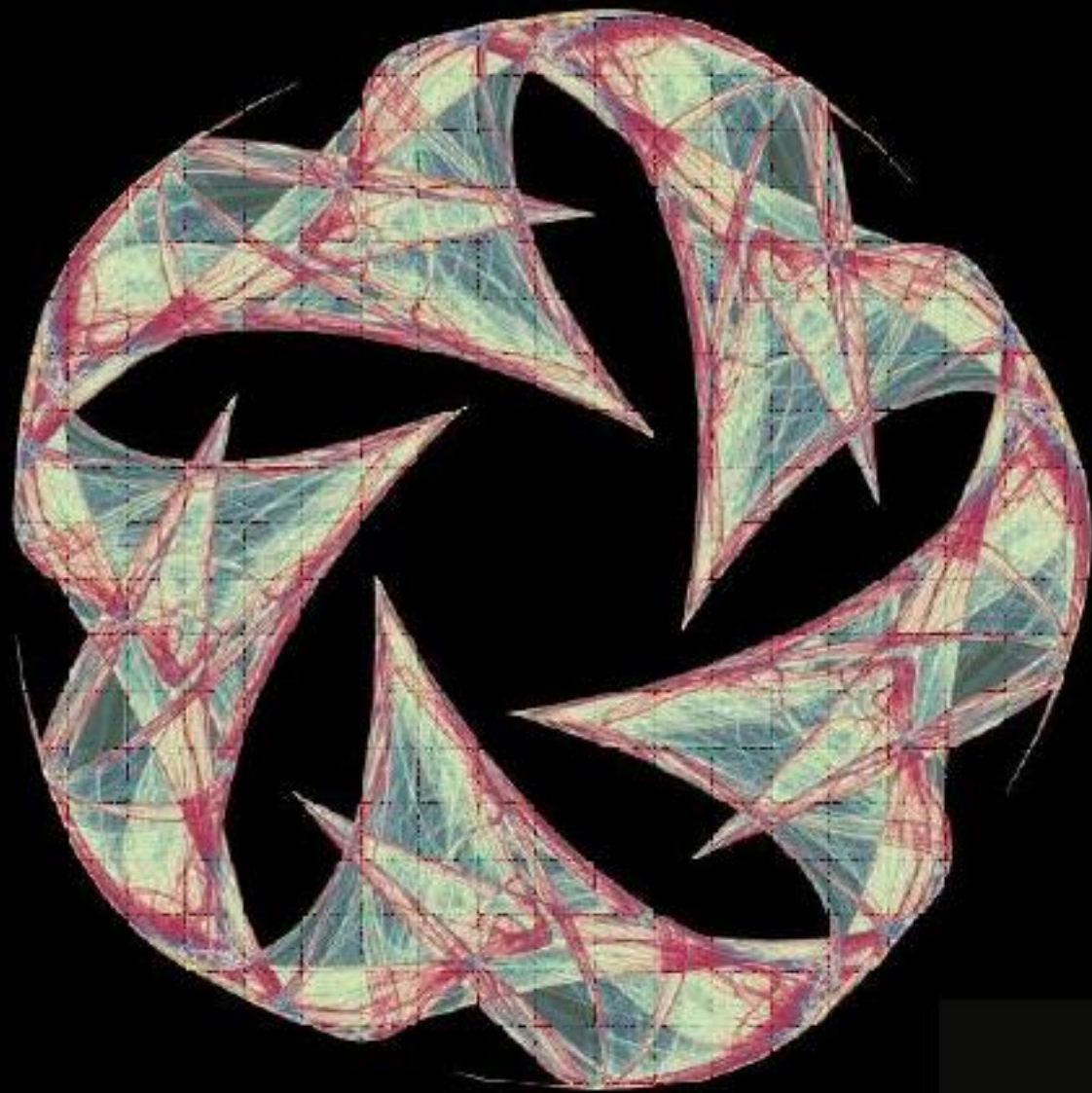

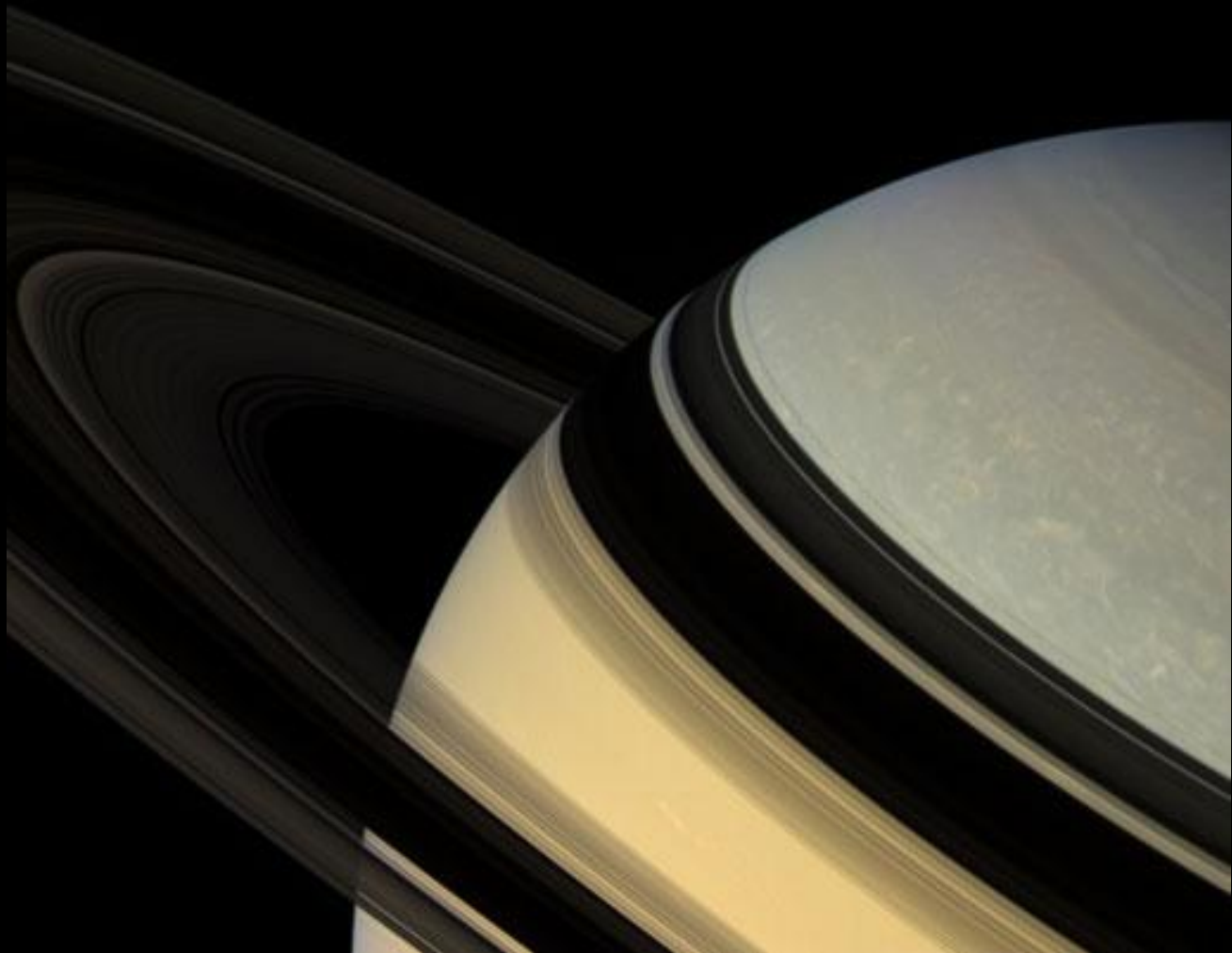

www.polymorf.net

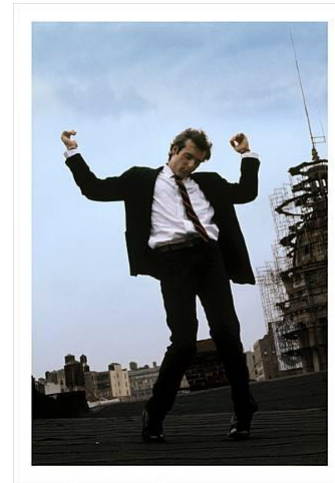
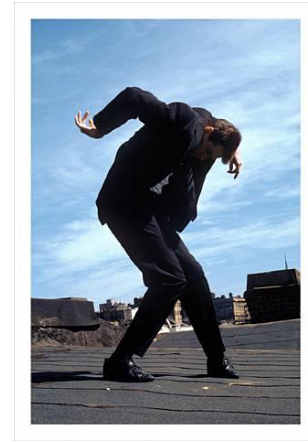
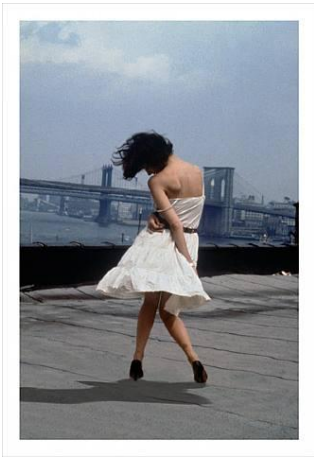



















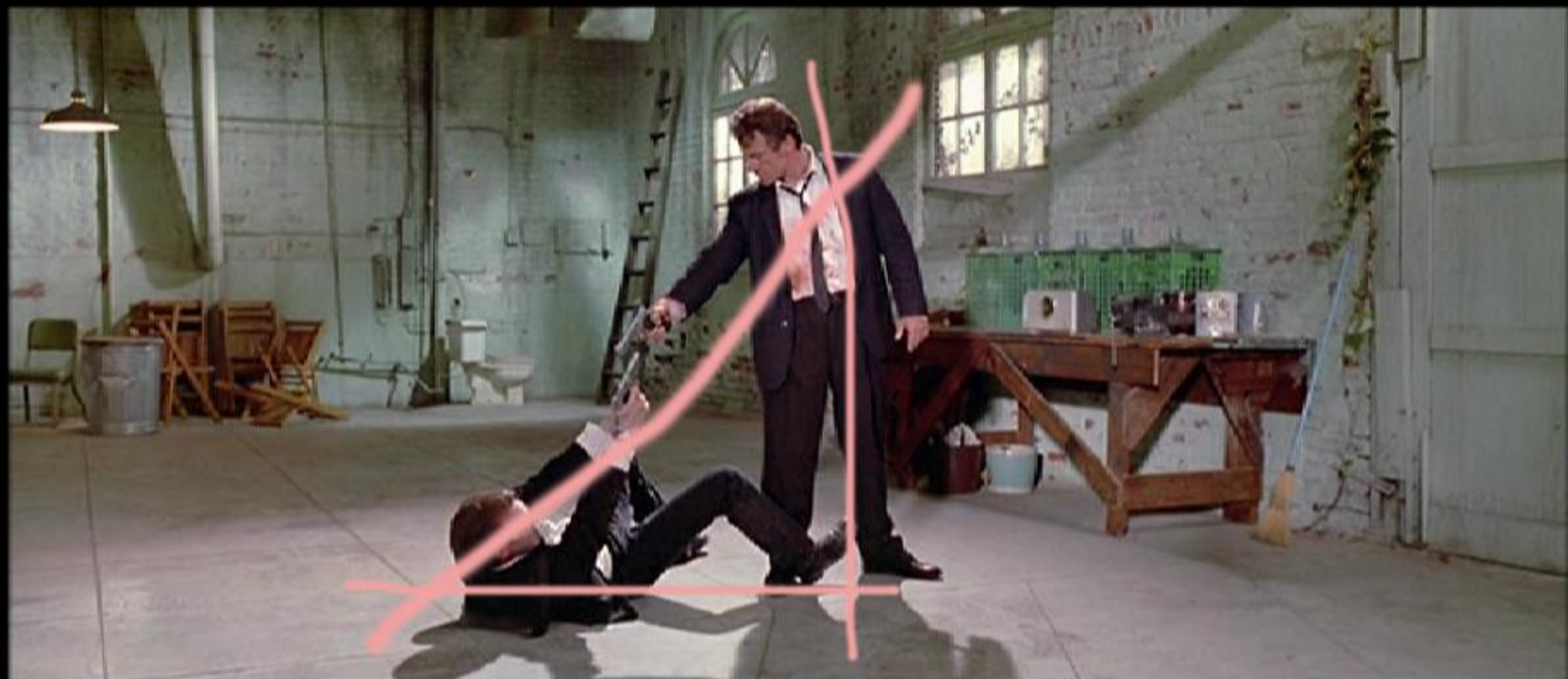

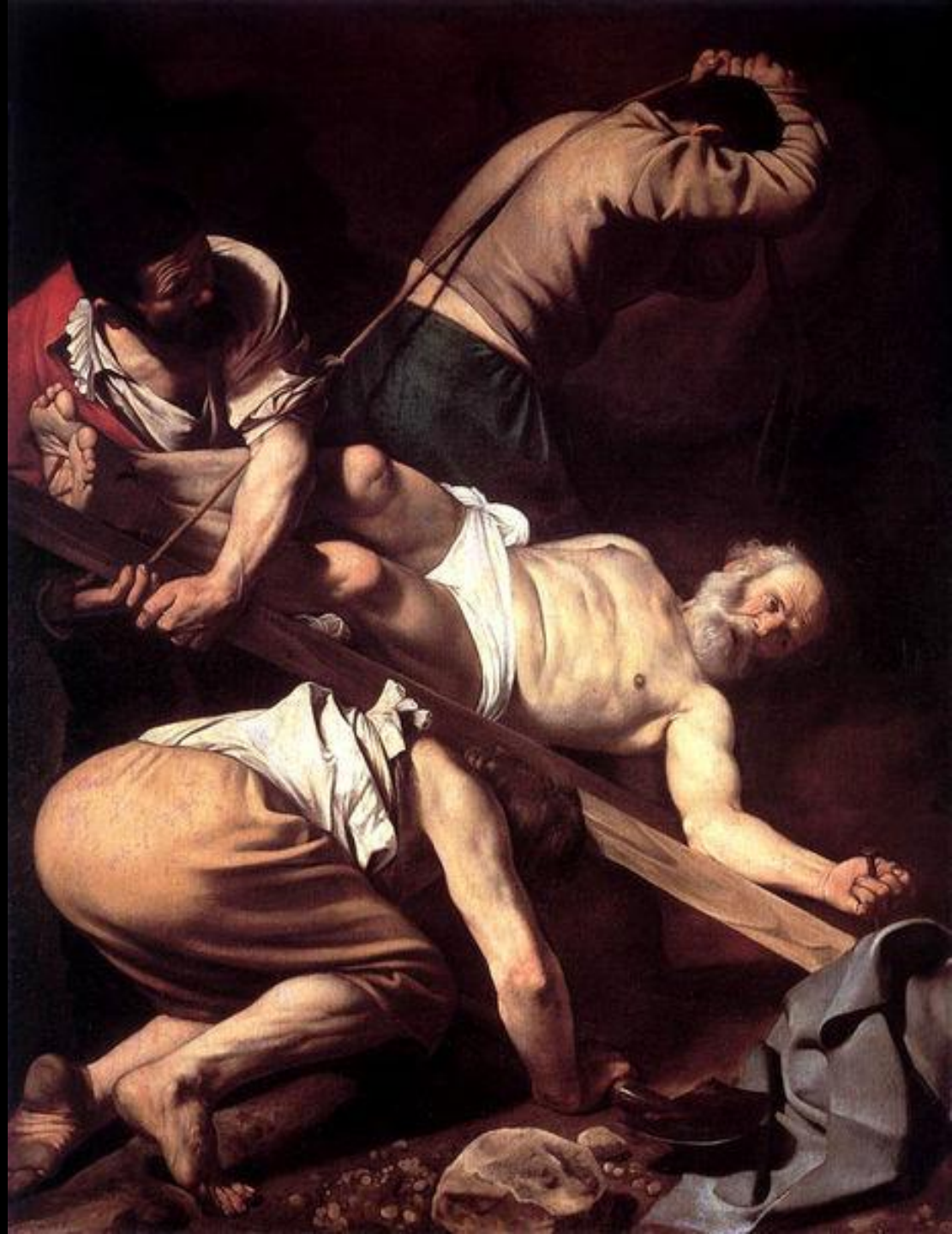



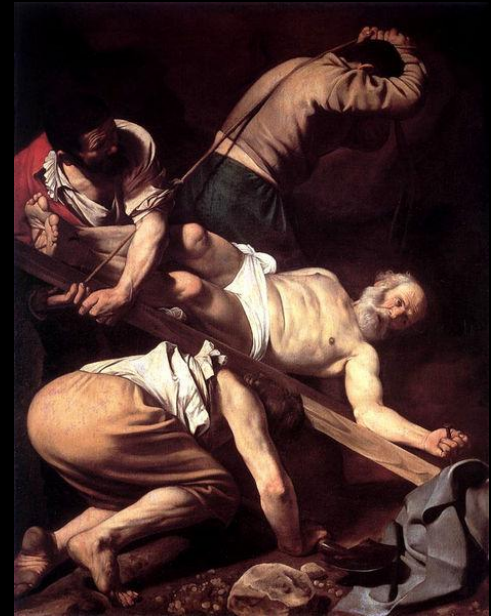



Will Alshop
, Ontario Art School, 2004

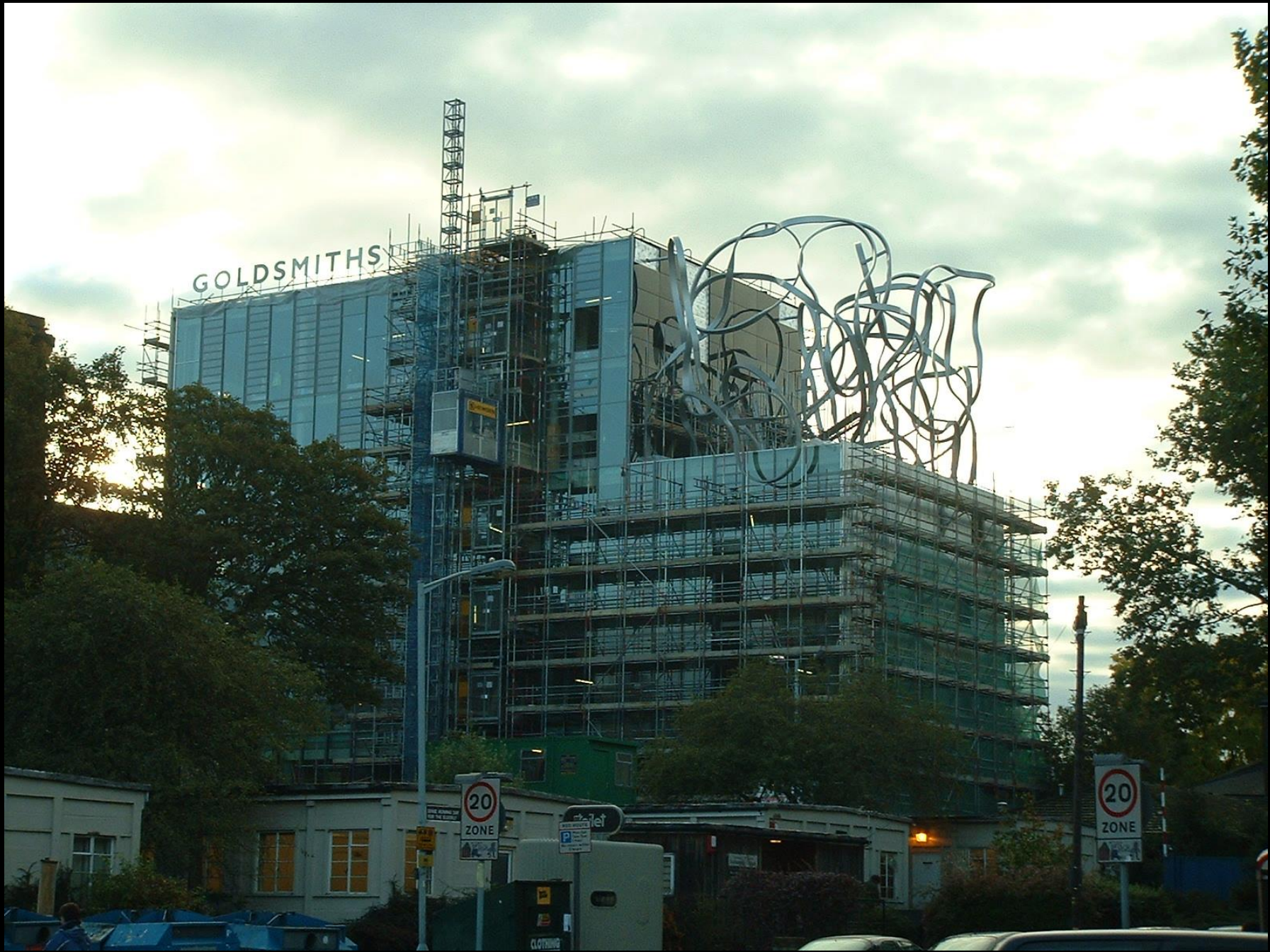

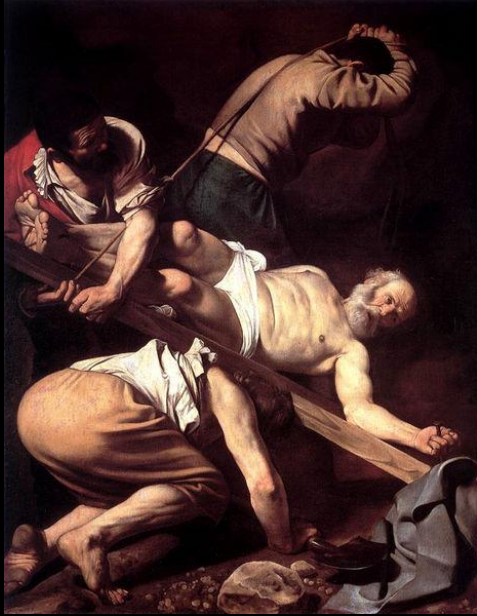











Photo © The National Gallery, London.





ΙΣΟΡΡΟΠΙΑ



ΣΥΜΜΕΤΡΙΑ

*Στατική
ισορροπία*



ΑΣΥΜΜΕΤΡΙΑ

*Δυναμική
ισορροπία*

Ισορροπία

ΠΑΝΕΠΙΣΤΗΜΙΟ ΔΥΤΙΚΗΣ ΜΑΚΕΔΟΝΙΑΣ
ΤΜΗΜΑ ΕΙΚΑΣΤΙΚΩΝ ΚΑΙ
ΕΦΑΡΜΟΣΜΕΝΩΝ ΤΕΧΝΩΝ

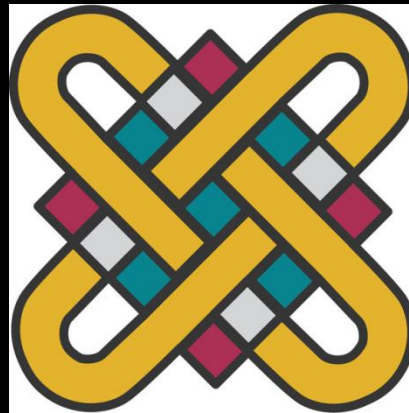

1^ο Εργαστήριο Ζωγραφικής
Κύκλος
Εννοιολογικές Θεματικές
Γιάννης Ζιώγας
Επίκουρος Καθηγητής