

# Mill Tutorial

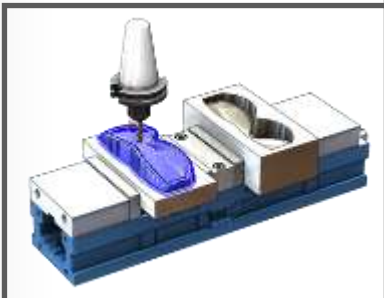
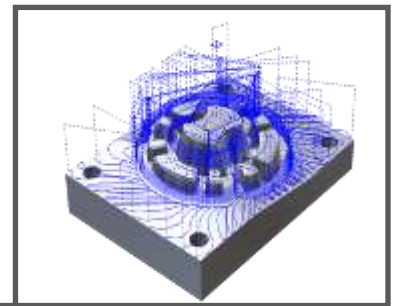

**SOLIDWORKS CAM**  
**2020**

## Copyright

© 1995-2019, Dassault Systemes SolidWorks Corporation, a Dassault Systèmes SE company, 175 Wyman Street, Waltham, Mass. 02451 USA. All Rights Reserved.

## Disclaimers

The information and the software application discussed in this document are subject to change without prior notice and are not commitments by Dassault Systemes SolidWorks Corporation (DS SolidWorks).

No material may be reproduced or transmitted in any form or by any means, electronically or manually, for any purpose without the express written permission of DS SolidWorks.

The software discussed in this document is furnished under a license and may be used or copied only in accordance with the terms of the license. All warranties given by DS SolidWorks as to the software and documentation are set forth in the license agreement, and nothing stated in, or implied by, this document or its contents shall be considered or deemed a modification or amendment of any terms, including warranties, in the license agreement.

## Trademarks

- SOLIDWORKS, 3D ContentCentral, 3D PartStream.NET, eDrawings, and the eDrawings logo are registered trademarks and FeatureManager is a jointly owned registered trademark of DS SolidWorks.
- CircuitWorks, FloXpress, PhotoView 360, and TolAnalyst are trademarks of DS SolidWorks.
- FeatureWorks is a registered trademark of Geometric Americas, Inc.
- Adobe, the Adobe logo, Acrobat, the Adobe PDF logo, Distiller and Reader are registered trademarks or trademarks of Adobe Systems Inc. in the U.S. and other countries.
- Other brand or product names are trademarks or registered trademarks of their respective holders.



The **3DEXPERIENCE**<sup>®</sup> Company

**Product Name: SOLIDWORKS CAM 2020**



# Table of Contents

**CHAPTER 1: LEARNING 2 AXIS MILL BASICS ..... 7**

**2 Axis Mill 1.....8**

Steps to Generate Mill Toolpaths and NC Code in Part Mode .....8

Step 1: Model Part in SOLIDWORKS or Import Part .....9

    Viewing the FeatureManager Design Trees ..... 9

Step 2: Change to SOLIDWORKS CAM Feature Tree ..... 10

    SOLIDWORKS CAM Machining Trees ..... 10

    SOLIDWORKS CAM Command Manager ..... 11

    SOLIDWORKS CAM Context-based Help ..... 12

Step 3: Define the Machine .....12

    Define the Machine ..... 12

Step 4: Define the Stock .....15

Step 5: Define Machinable Features .....15

    Defining Features Interactively..... 18

Step 6: Generate Operation Plan and Toolpath .....19

    Generate Operation Plan Command ..... 19

    Exclamation mark symbol over certain operations..... 21

    Generate Toolpath Command ..... 22

Step 7: Adjusting Toolpath Parameters .....23

    Simulate Toolpath..... 24

    Step Through Toolpath ..... 26

Step 8: Post Process Toolpaths.....28

**2 Axis Mill 2.....32**

Extracting and Working with Machinable Features.....32

Tool Crib Tab .....33

    Tool Crib Priority..... 33

    Tool Crib has Sub Stations ..... 33

    Editing the Tool Crib ..... 33

    Modifying the Tools in the Technology Database..... 35

Post Processor Tab and Posting Tab .....37

Defining the Stock .....37

Extract Machinable Features .....38

    Setting Features Types to be recognized by AFR..... 39

    Rebuild the Features ..... 40

    Setting Feature Strategy ..... 41

    Mill Part Setup ..... 42

Generate Operation Plan.....42

    Locating Operations for Selected Feature..... 45

**2 Axis Mill 3.....47**

Step 1: Opening the Part and Defining the Machine.....	47
Step 2: Defining the Stock from a Bounding Box.....	48
Executing Extract Machinable Features Command.....	48
Step 3: Interactive Feature Recognition .....	48
Need for Interactive Feature Recognition.....	48
Deleting a Feature .....	49
Inserting Additional Mill Part Setups .....	49
Reorganizing Machinable Features.....	51
Suppressing Machinable Features.....	51
Inserting 2.5 Axis Features .....	52
Combining Machinable Features .....	56
Step 5: Generate Operation Plan and Toolpaths .....	57
Generate an Operation Plan for each Mill Part Setup.....	57
Generate Toolpaths and Post Process the Part.....	58
SOLIDWORKS CAM Message Window .....	58
Simulating the Toolpath.....	58
Step 6: Post Processing the Toolpaths.....	59
<b>2 Axis Mill 4.....</b>	<b>60</b>
Sequence of machining: .....	60
Step 1: Opening the Part and Defining the Machine.....	61
Step 2: Defining the Stock from a Sketch .....	61
Step 3: Extracting Machinable Features.....	62
Settings for Recognizing Face Feature Automatically .....	62
Automatic Feature Recognition .....	62
Step 4: Interactively Inserting Features .....	63
Steps to Interactively insert an Open Pocket Feature .....	63
Step 5: Generating Operations .....	65
Changing Feature Strategy before Generating Operations .....	65
Executing Generate Operation Plan Command .....	66
Adjusting Operation Parameters .....	67
Expanding and Collapsing Items in the Tree .....	67
Deleting an Operation .....	70
Inserting an Operation.....	70
Step 6: Defining Program Zero .....	75
Step 7: Generate and Simulate Toolpaths .....	76
Step 8: Sorting Operations .....	77
Step 9: Simulate Toolpath and Post Process .....	79
<b>CHAPTER 2: LEARNING MORE 2 AXIS MILL.....</b>	<b>81</b>
<b>2 Axis Mill 5.....</b>	<b>82</b>
Opening the Part and Extracting Machinable Features by AFR .....	82
Setting Strategies and Generating Operations.....	83
Sorting and Sequencing Operations .....	84
Machining Island Tops .....	86
Changing the Mill Part Setup Origin.....	86

Combining Operations.....	88
Changing Tool Parameters and Generating Toolpath .....	89
Simulate Toolpath and Post Process .....	90
<b>2 Axis Mill 6.....</b>	<b>91</b>
Opening the Part .....	91
Defining Stock.....	92
Defining Fixture Coordinate System of the Mill machine .....	92
Automatic Feature Recognition Settings.....	93
Extracting Machinable Features .....	94
Renaming Mill Part Setups.....	94
Rearranging features using Drag and Drop Functionality .....	94
Generating Operations.....	95
Defining Avoid Areas for Clamps.....	95
Copying Avoid Areas from one Operation to another .....	96
Modifying Operation Parameters before Generating Toolpaths .....	97
Generating Toolpaths .....	102
Simulating Toolpaths.....	102
Customizing Toolpaths.....	102
<b>2 Axis Mill 7.....</b>	<b>105</b>
Opening the Part and Recognizing Features Automatically .....	105
Defining Features Interactively .....	106
Inserting Engrave Features .....	108
Generating an Operation Plan and Adjusting Operation Parameters .....	108
Associating Machining Information after Design Changes .....	111
Simulation Toolpath .....	114
Changing the color of Simulation Toolpath operations .....	115
<b>2 Axis Mill 8.....</b>	<b>116</b>
Step 1: Opening the Part and Defining the Machine and Stock.....	116
Step 2: Extracting Machinable Features and Generating Operations .....	116
Step 3: Specifying a Tool Overlap on Open Air Segments.....	117
Step 4: Using an Avoid Area.....	118
Step 5: Defining Rapid and Clearance Planes.....	119
<b>2 Axis Mill 9.....</b>	<b>122</b>
Open the Part and Defining the Machine and Stock .....	122
Defining Features Interactively .....	122
Creating a Pattern Feature .....	124
Inserting a Pattern Feature (Linear Pattern).....	124
Inserting a Pattern Feature using a sketch (Sketch-driven Pattern) .....	126
<b>2 Axis Mill 10.....</b>	<b>127</b>
Open the Part and Defining the Machine and Stock .....	127
Defining Features Interactively .....	127
Define the 2.5 Axis feature for the circular pattern .....	128
Creating a Pattern Feature .....	129



---

Inserting a Circular Pattern Feature .....	129
Inserting a Sketch-Driven Pattern Feature .....	129
<b>For More Practice.....</b>	<b>132</b>
Part1 for Practice .....	132
Part2 for Practice .....	132
<b>CHAPTER 3: LEARNING 3 AXIS MILL .....</b>	<b>134</b>
<b>3 Axis Mill 1.....</b>	<b>135</b>
Open the Part and Defining the Machine and Stock .....	135
Define the Machine.....	135
Define the Stock.....	135
Inserting a Mill Part Setup and Creating a Multi Surface Feature .....	136
Generating Area Clearance Toolpaths .....	136
Generate Operations and Toolpaths.....	136
Inserting Contain Areas to Selectively Machine Areas .....	137
Generating Z Level Toolpaths.....	139
Inserting an Avoid Area to Selectively Machine Areas .....	141
Using User-defined Limits to Machine Specific Areas .....	141
Generating Flat Area Toolpaths .....	143
<b>3 Axis Mill 2.....</b>	<b>144</b>
Open the Part .....	144
Using Automatic Contain Areas.....	144
Stock Method .....	144
Bounding Box Method.....	145
Outer Silhouette Method.....	146
All Silhouettes Method .....	146
<b>LEGAL NOTICES .....</b>	<b>148</b>

---

## Chapter 1: Learning 2 Axis Mill Basics

---

This chapter provides an opportunity to learn 2 Axis Mill through a step by step hands-on tour of the features and functions.

The exercises in this chapter are intended to show you how to use SOLIDWORKS CAM and may not correspond to actual machining practices.

The exercise parts are installed when you install SOLIDWORKS CAM and are in the `\SOLIDWORKS\SOLIDWORKS 201x\CAM Examples\Tutorial_Parts\Mill` folder.

(Typical Location: `C:\Users\Public\Public Documents\SOLIDWORKS\SOLIDWORKS 201x\CAM Examples\Tutorial_Parts\Mill`).

---

**IMPORTANT!** SOLIDWORKS Cam uses a set of knowledge-based rules to assign machining operations to features. The Technology Database contains the data for the machining process plans and can be customized for your facility's machining methodology. When you do these exercises, your results may not be the same as described in the steps and illustrated in the figures. This is because the machining sequences and operations data in your Technology Database may be different from the database used to produce the documentation.

---

The following series of exercises show you how to generate finish toolpaths on a SOLIDWORKS part model.

In order to give you a general understanding of how to use SOLIDWORKS CAM, you will work with a part that was previously modeled in SOLIDWORKS. When you define the operations and toolpaths, you will follow steps and instructions. These steps and instructions are brief in nature in order to show you the basics of generating toolpaths from start to finish without getting into the details at this time. In case you wish to have deeper understanding of the functionalities within SOLIDWORKS CAM, we recommend that you refer to **SOLIDWORKS CAM Context-based Help**. This context-sensitive Help is displayed when you click on the Help button of the various dialog boxes or User Interfaces within the application.

## 2 Axis Mill 1

### Topics covered in this tutorial:

#### Steps to Generate Mill Toolpaths and NC Code in Part Mode

The following steps are used to generate Mill toolpaths and NC code:

1. Model the part or open the part file in SOLIDWORKS.
2. Click on the SOLIDWORKS CAM Feature tree.
3. Define the Machine and modify the controller parameters.
4. Define the stock.
5. Define machinable features.
6. Generate the operation plan and adjust operation parameters.
7. Generate toolpaths.
8. Simulate material removal.
9. Post process the toolpaths.

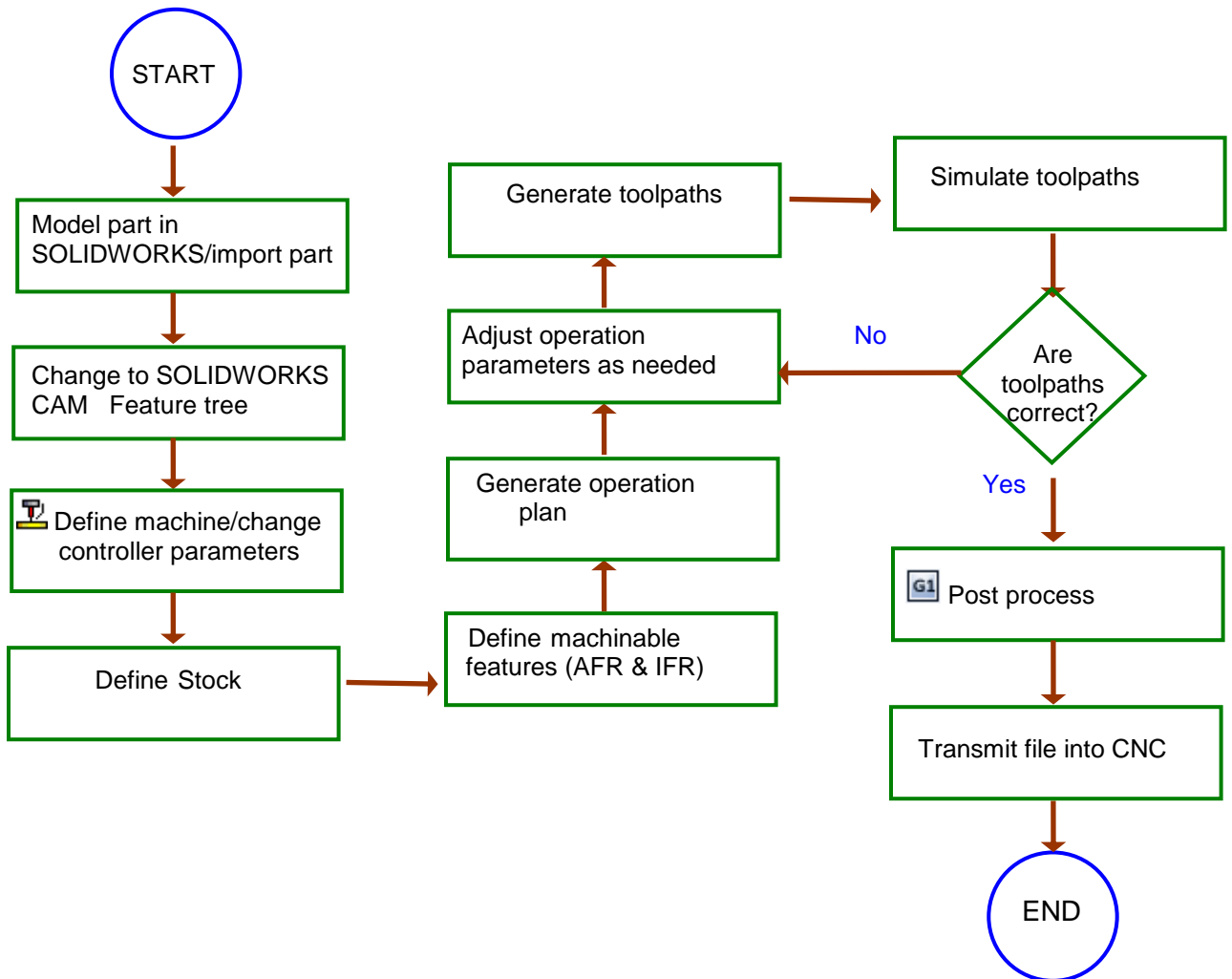



## Step 1: Model Part in SOLIDWORKS or Import Part

A part is a solid that is created with SOLIDWORKS or imported into SOLIDWORKS from another CAD system via an IGES, Parasolid, SAT file, etc. This exercise uses an existing SOLIDWORKS part.

Open the part file **MILL2AX\_1.SLDPRT** in the following folder.

*C:\Users\Public\Public Documents\SOLIDWORKS\SOLIDWORKS 201x\CAM Examples\Tutorial\_Parts\Mill.*

### Viewing the FeatureManager Design Trees

The FeatureManager design tree  displays the list of the features, sketches, planes and axes related to the part.

To use SOLIDWORKS CAM, you need to move between SOLIDWORKS trees and the SOLIDWORKS CAM Feature trees. Different tabs are provided to access the SOLIDWORKS trees and the SOLIDWORKS CAM Feature trees. Click the  *Pin* button to continuously view this Tree area.

If the SOLIDWORKS CAM tabs [] are not visible, you can expand the size of the tree. Position the cursor on the line that divides the tree area from the graphics area. When the cursor changes to a bar, drag the bar to the right until the tabs display.

Tabs for SOLIDWORKS  
Trees

SOLIDWORKS CAM Feature  
Tree tab

Line that divides the tree from the  
graphics area

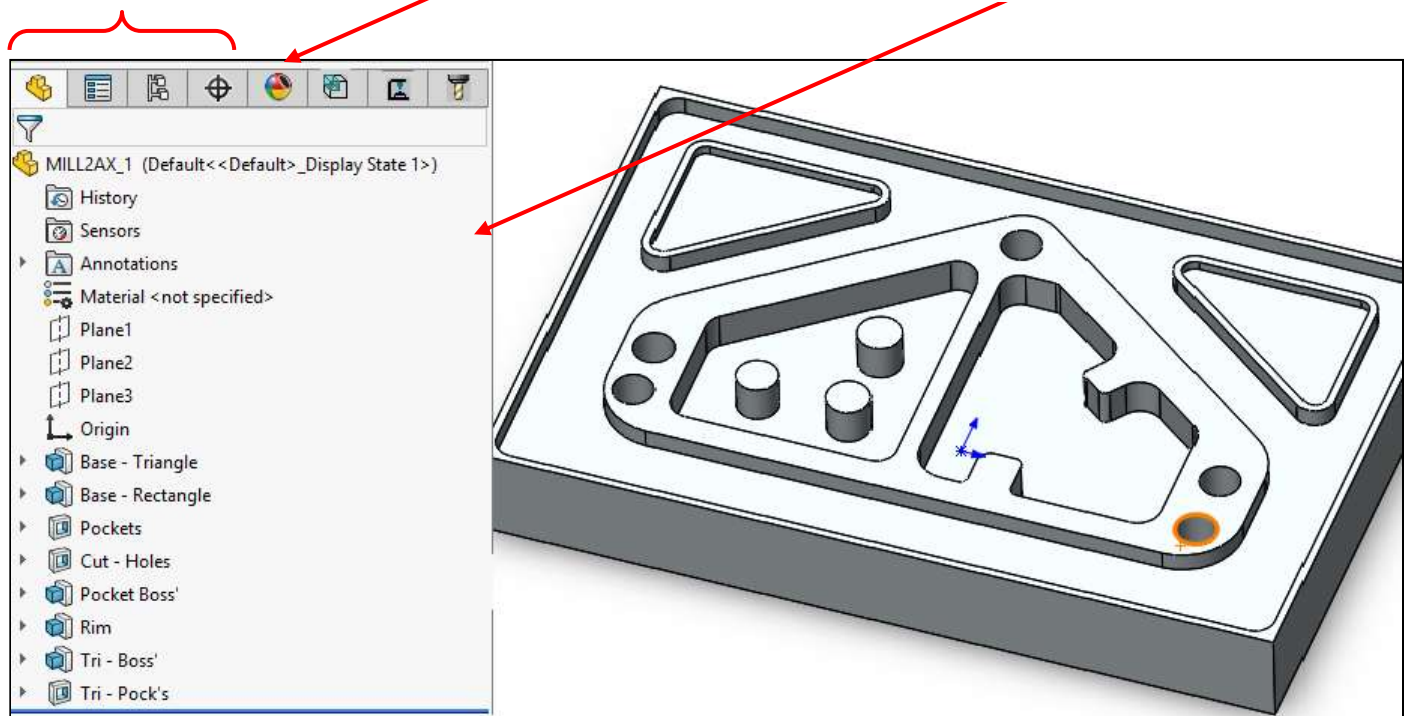

Graphics area

Items under the Feature  
Manager Design tree

## Step 2: Change to SOLIDWORKS CAM Feature Tree

Click the *SOLIDWORKS CAM Feature Tree* tab to view the items under this tree.

Initially, the tree lists the SOLIDWORKS CAM NC Manager, Stock Manager, Machine and Recycle Bin items.

### **SOLIDWORKS CAM Machining Trees**

The SOLIDWORKS CAM machining trees provide an outline view of the machining information for the model. Initially, the SOLIDWORKS CAM Feature tree shows only the SOLIDWORKS CAM NC Manager, Configurations, Stock Manager, Machine and Recycle Bin items. As you follow the steps to generate an NC program, this tree expands to include Mill Part Setups and machinable features.

-  **Configurations**

Multiple SOLIDWORKS CAM datasets are supported. Each dataset is called a configuration. You can use configurations to support multiple machines and SOLIDWORKS configurations.

-  **Stock Manager**

The stock is the material from which the part will be machined. If the Machine type chosen is Mill, you can define the stock as a rectangular shape (bounding box) or an extruded sketch or an STL file. You can also specify the type of material.

-  **Machine**

The Machine item defines the machine tool that the part will be machined on. The machine definition includes the type of machine (e.g.: Mill, Turn,), Tool definitions and the Post processor. The machines are set up in the Technology Database.

-  **Recycle Bin**

The Recycle Bin in the SOLIDWORKS CAM Feature tree is used to store machinable features that you do not intend to machine.

## **SOLIDWORKS CAM Command Manager**

Click *Tools* on the SOLIDWORKS menu bar and select SOLIDWORKS CAM from the dropdown menu. Click *SOLIDWORKS CAM* on the menu bar. This action displays the SOLIDWORKS CAM Command Manager. It provides access to the main SOLIDWORKS CAM commands. The commands are explained in the SOLIDWORKS CAM context-based Help.

### **Customization of SOLIDWORKS CAM Command Manager**

Command Manager is a context-sensitive toolbar that can be dynamically updates based on the toolbar you want to access. It provides access to the main SOLIDWORKS CAM commands found on the SOLIDWORKS CAM menu. By default, it has toolbars embedded in it.

The SOLIDWORKS CAM Command Manager can be customized. Right click anywhere on the SOLIDWORKS CAM Command Manager and select *Customize menu* from the RMB context menu. The *Customize* dialog box will be displayed. Use the *Toolbars, Commands, Menus, Keyboard shortcut, Mouse gesture and Options* tab of this dialog box to customize the Command Manager as per your requirements.

### Alternative Access to SOLIDWORKS CAM Commands

All the commands executed from the SOLIDWORKS CAM Command Manager can also be alternatively accessed from the RMB context menu of the SOLIDWORKS CAM NC Manager. This is a context menu. To execute the command, right click on the *SOLIDWORKS CAM NC Manager* item in the tree and select the desired command from the RMB context menu. In addition to the Command Manager commands, this right click context menu also provides access to a variety of commands.

### SOLIDWORKS CAM Context-based Help

In addition to tutorial documents, SOLIDWORKS CAM is provided with a context-based Help. Every dialog box and interface within SOLIDWORKS CAM has an associated *Help* button. Click on the *Help* button  on the SOLIDWORKS CAM Command Manager to open the context-based Help. Every parameter and tab of each dialog box is explained in the context-based Help.

### Step 3: Define the Machine

The machine includes information that identifies what to machine, how to machine it, and the format of the NC output. Important parameters of the machine definition include:

- **Machine type – Mill or Turn:** The machine type defines the machinable feature set that can be recognized automatically and defined interactively.

The icons that display in the tree identify the current machine:

 **Mill Machine**    **Turn Machine**

An alternative machine can be selected at any time to output different G-code programs for alternative machine tools. If the machine type changes, then all features and operations will be deleted.

- **Tool crib:** A subset of tools from the tool library that are commonly loaded into or used with the current machine.
- **Post Processor:** The post processor identifies the format of the NC G-code output.

### Define the Machine

1.  Right click *Machine [Mill – Metric]* in the SOLIDWORKS CAM Feature tree and select *Edit Definition* or double click the item in the tree.



#### Did You Know ...

**In the Feature and Operation trees, instead of right clicking items and selecting *Edit Definition*, you can double-click the item to open the dialog box for editing the Stock Manager, Machine, Setups, Features and Operations.**

The Machine dialog box displays the Machine tab. The default machine is specified in the Technology Database. *Machine [Mill–Metric]* is the default machine used for the metric parts in this manual. When you use SOLIDWORKS CAM to machine your own parts, select the machine tool you want to use to machine the part.

Machine tools are set up in the Technology Database. Before using SOLIDWORKS CAM to machine your parts, make sure you define the machine tools available in your facility. For more information, refer the PDF manual “*Technology Database Tutorial*”.

- In the Available machines list, highlight *Mill–Metric* and click the *Select* button.
- Click the *Tool crib* tab and make sure *Tool Crib 2 (Metric)* is the Active tool crib.

The Tool Crib page allows you to choose a Tool Crib, which is a set of tools or tool assemblies that are used with the machine you have chosen. These are not all the tools that are available, but a subset that you can modify to represent the actual set of tools that the machine has loaded.

*Tool Crib 2 (Metric)* is a default tool crib that has been set up for the sample Mill machine. When you define your machine tools in the Technology Database, you can set up your own tool cribs.

- Click the *Post Processor* tab.

This tab allows you to select the internal post processor or the APT CL option to output a CL file. The list that displays depends on the post processors that are installed on your system.

SOLIDWORKS CAM is supplied with several tutorial post processors. Contact your SOLIDWORKS CAM Reseller for more information on obtaining and/or customizing post processors for your machine tool.

If the post processors do not display, use the *Browse* button to locate the folder containing the files (\*.ctl).

- If *M3AXIS-TUTORIAL* (the tutorial post processor) is not the Active post processor, highlight it in the list and click the *Select* button. This post processor is used for

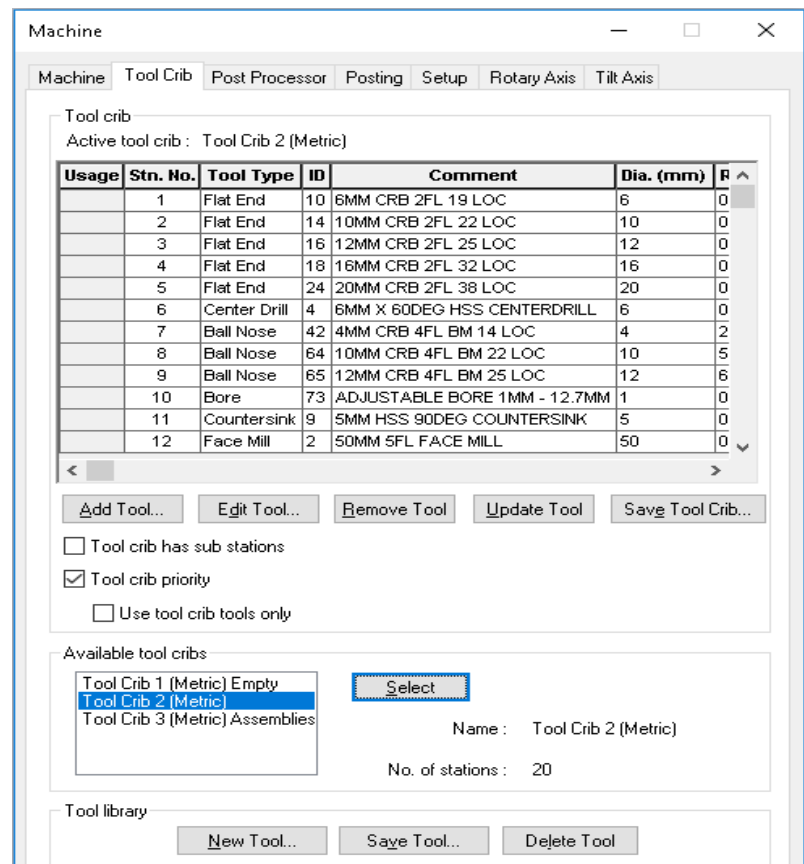

**Tool Crib tab of Machine Dialog Box**



exercise in this manual. When you use SOLIDWORKS CAM to machine your own parts, you can select your machine tool controller or post processor.

When you select this post processor, a short description displays in the window. This window contains information only if an optional file has been created for the post processor.

6. Click the *More* button.

A longer description is displayed. The *More* button is activated only if a second optional file has been created. This information is intended for use in training or as a detailed description of post processor attributes that can be created.

Information files are provided for the sample post processor that is used for the exercises in this manual. Your Reseller or your company manager may be able to supply these files if they are available for your post processor. If files are not available, you can create post information files as explained in the context-based Help.

7. Click the *Posting* tab.

The parameters on this page are used for the following:

- To provide information required to generate the NC program. The parameters are machine-dependent and different parameters may display for your controller. The value for a parameter is output in the NC code if the machine requires it.
- To provide information for the Setup Sheet, a file that is created when the NC program file is generated. All of the controller parameters are included in the Setup Sheet.

8. Type **1001** for the Program Number and press the down arrow on the keyboard to shift the focus to the Part Thickness field.

9. Type **40mm** for the Part Thickness.

10. Click *OK* to close the machine dialog box.

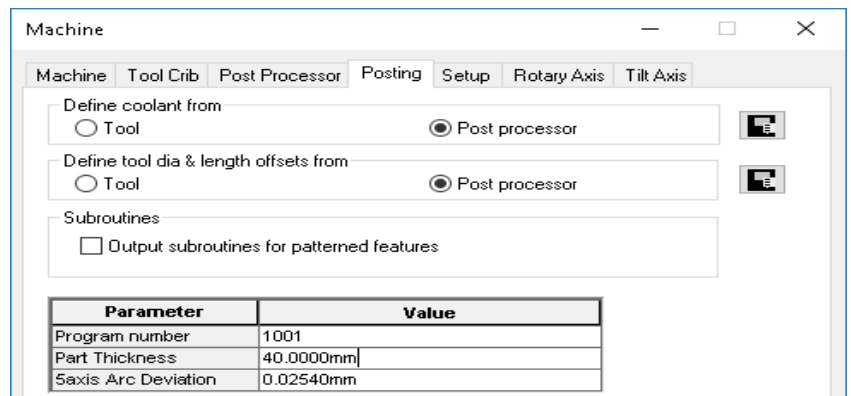

**Posting tab of Machine Dialog Box**

## Step 4: Define the Stock

The stock is the material from which the part will be machined. The default stock is the smallest cube (*bounding box*) that the part will fit into. Typically, this is not the size of the stock you will be using. You can change the stock definition either by offsetting the bounding box from the part or by defining the stock from a sketch and a depth (*extruded sketch*) or from an STL file.

In this tutorial, you define the stock as a box offset (*bounding box*) from the part.

1. Double click *Stock Manager* in the SOLIDWORKS CAM Feature tree.  
The Stock Manager dialog box is displayed.
2. For the Bounding box offset, type **1mm** for X+ and click the X+ button (Uniform X).
3. Repeat step 2 for Y+ and Z+. To set these entered values as default values for future jobs, click on the *Set default* button. Use the *Get default* button to set the offset values to pre-defined default values.
4. Select **304L** as the material from the *Material* dropdown list.
5. Click *OK* to close the dialog box.

**Stock Manager Dialog box**

## Step 5: Define Machinable Features

In SOLIDWORKS CAM, machining can be done only on machinable features. You use the following method to define machinable features:

- **Interactively Created Features**

If AFR does not recognize a feature you want to machine, you need to define the feature interactively using the *New 2.5 Axis Feature* command. If you have 3 Axis Milling, multi-surface features can be defined using the *New Multi Surface Feature* command.





### Did You Know ...

You can select the type of 2.5 features that you want AFR to recognize. Open the Options dialog box. You can select the type of features to be recognized by selecting the desired features in the Feature Types group box on the Mill Features tab of this dialog box.

### Defining machinable features automatically:



Click the *Extract Machinable Features* button on the SOLIDWORKS CAM Command Manager.

The *SOLIDWORKS CAM Message Window* displays automatically to report the progress and status of the process.

You can control whether this window displays temporarily or permanently. Click on the  *SOLIDWORKS CAM Options* button on the SOLIDWORKS CAM Command Manager. The *Options* dialog box is displayed. Check the *Message Window* option on the *General* tab of this dialog box to view this window continuously.

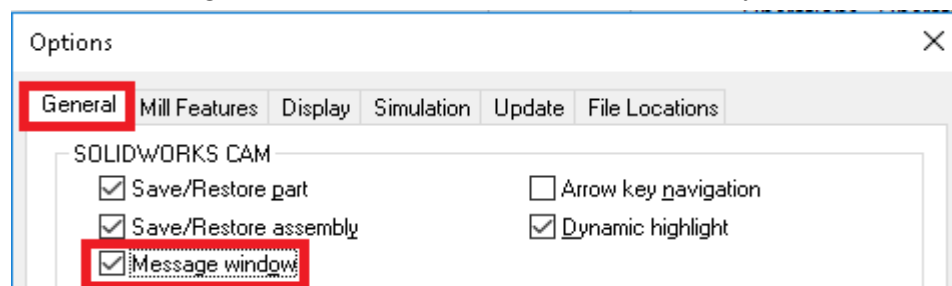

**General Tab of SOLIDWORKS CAM Options dialog box**

SOLIDWORKS CAM generates the Mill Part Setup and machinable features. The items display in the *Feature* tree.

The Mill Part Setup is the 2 axis plane that the tool movement will be based on. It has an origin location, and X, Y, Z direction vectors. The Mill Part Setup is created automatically; however, you can move the origin, and change the direction and angles of the X and Y axes.

A Mill Part Setup is created for each different tool orientation. There is only one Mill Part Setup for this part because all features can be machined using a single tool orientation. For each Mill Part Setup, the machinable features are listed in the order in which they were recognized.

The *Feature* tree allows you to:

- Copy, rename, suppress, delete and combine machinable features
- Change machinable feature parameters
- Change the order in which the features are machined



- Insert 2.5 Axis and Multi Surface features
- Search for a feature based on item name
- Hide or show feature display in graphics area



### Did You Know ...

Features display in a different color when they have no operations generated. Once operations are successfully generated, they display in another color. If operations are not generated for certain features (this occurs when feature conditions have not been defined in the Technology Database), then they retain their original color indicating non-generation of operations. You can set the color on the Display tab in the Options dialog box.

Most feature parameters are fixed; however, some parameters can be changed using the *Parameters* command on the feature's RMB context menu.

1. Right click *Hole Group1* in the tree and select *Parameters* on the context menu.

The *Hole Parameters* dialog box displays the number of components and the hole parameters. Since there is no physical information about the type of hole, SOLIDWORKS CAM allows you to define a Strategy for the hole (Drill, Bore, Ream, Thread or a user-defined Strategy).

2. Click the down arrow next to *Drill* to see the choices.
3. Click *Thread* in the list.

The figure changes to reflect your choice and the Thread parameters are enabled.

4. Click the *Strategy* dropdown list and select *Drill* again.
5. Click *OK* to close the dialog box.

6. Click the  next to *Hole Group1* in the SOLIDWORKS CAM Feature tree.

The tree expands to display each individual hole.

7. Click the  next to *Hole Group1* in the Feature tree.

The tree collapses hiding the individual hole features.

8.  Click the SOLIDWORKS CAM *Options* button on the SOLIDWORKS CAM Command Manager.

Note that you can also select the *Options* command from the RMB context menu of the SOLIDWORKS CAM NC Manager in the tree.

- The *Options* dialog box is displayed.
- On the *General* tab, make sure the *Save/Restore part* option is checked.
- Click *OK* to apply the settings and close the dialog box.



**Hole Group**

If this *Save/Restore part* option is checked, when you save and close a part document, the machining data is saved and restored with the part design information when the part document is reopened.

If this option is not checked, when you save and close a part document that contains at least one Setup, a message indicates that Save/Restore is disabled. If you click Yes, SOLIDWORKS CAM saves all machining data before closing the file. If you click No, SOLIDWORKS CAM closes the part and discards any new machining data since the last save.

9. Select *Save As* on the File menu. Browse to the location where you wish to save the file.
10. In the *Save As* dialog box, assign the desired file name and click the *Save* button.

### SAVE FREQUENTLY!

- When you open a file, you are actually working on a copy of the file. The original is still stored on disk. Periodically saving your file ensures that your latest work is retained.
- SOLIDWORKS CAM provides an Auto save option on the General tab in the Options dialog box for automatically saving your SOLIDWORKS CAM data.
- Frequent saves prevent having to redo a time-consuming model or CAM operation. If a power failure occurs, you will lose whatever you have been working on.

### Defining Features Interactively

Automatic Feature Recognition can save a significant amount of time; however, AFR does have limitations. AFR cannot recognize every feature on complex parts and does not recognize some types of features. To machine these areas, you can define machinable features interactively using the *New 2.5 Axis Feature* command. For some parts, Face Features can be recognized by AFR by selecting the Face option under the *Feature Types* group box

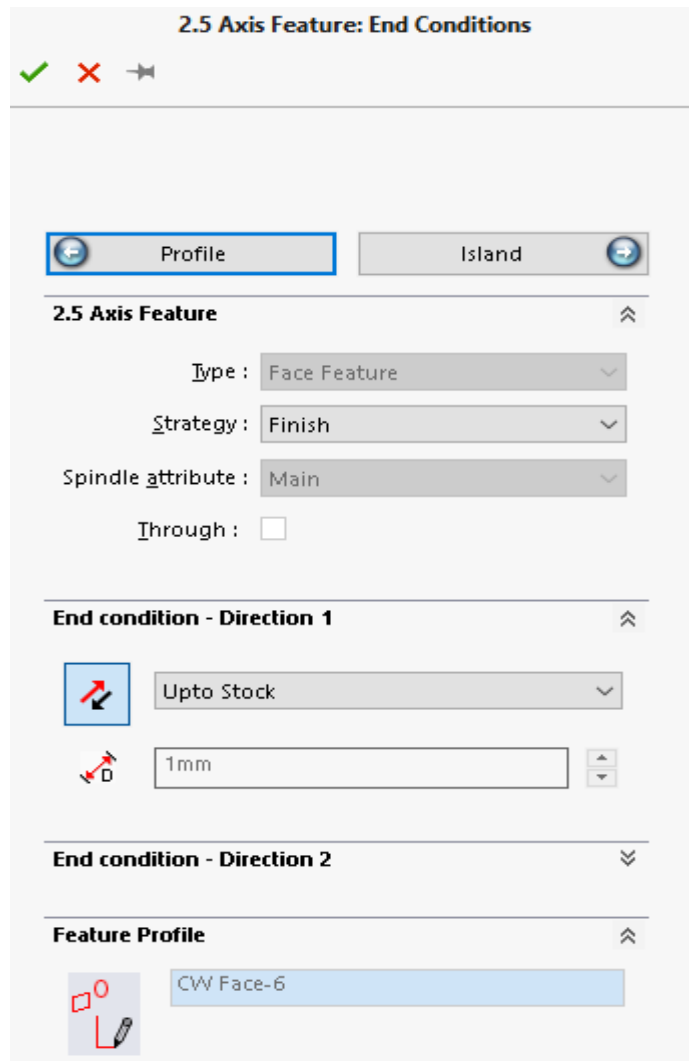

**2.5 Axis Feature: End conditions dialog box**

on the *Mill Features* tab in the *Options* dialog box.

For learning purposes, in this tutorial, you will insert a Face Feature so that you can face the top of the part. In order to define a Face Feature, you select a face on the SOLIDWORKS part that is at the depth you want to face the part to.

1. Right click *Mill Part Setup1* in the SOLIDWORKS CAM Feature tree and select *2.5 Axis Feature* on the context menu.

The *2.5 Axis Feature: Select Entities* dialog box will be displayed.

2. Click the down arrow next to the *Type* dropdown list box and select *Face Feature*.

3. Pick the top main face as shown on the right. The outline of the face will be highlighted on the part and *CW Face-6* will be displayed in the *Selected Entities* list.



4. Click the *End Condition* button at the top right of the dialog box.

The *2.5 Axis Feature: End Conditions* dialog box will be displayed. This dialog box allows you to determine how SOLIDWORKS CAM calculates the depth of the feature and select a Strategy that defines a unique machining sequence.

5. In the *Strategy* dropdown list, select *Finish*.

6. In the *End Condition – Direction 1* group box, leave the *End condition Type* set to *Upto Stock*.

7. Click *OK* button to insert the feature and close the dialog box.

8. *Face Feature1* will be displayed in the SOLIDWORKS CAM Feature tree. You have now defined all the machinable features in this part and you are ready to generate the Operation Plan.

## Step 6: Generate Operation Plan and Toolpath

### ***Generate Operation Plan Command***

An Operation Plan contains information on how each machinable feature is to be machined and how the NC code will be output. When Generate Operation Plan is run, operations for each machinable feature are created automatically based on information in the Technology Database. In some situations, the operations defined for a feature in the Technology Database may not be sufficient and additional operations may be required. You can insert operations interactively using the *New 2 Axis Operation*, *New Hole Operation* and *New 3 Axis Operation* commands. These commands are explained in the SOLIDWORKS CAM context-based Help.

Select one of the following methods to generate an operation plan:



Click the *Generate Operation Plan* button on the SOLIDWORKS CAM Command Manager.

OR

Right click *Mill Part Setup1* in the SOLIDWORKS CAM Feature tree and select *Generate Operation Plan* on the context menu.

OR

Right click *SOLIDWORKS CAM NC Manager* in the SOLIDWORKS CAM Feature tree and select *Generate Operation Plan* on the context menu.

**Note:**

- If you execute the *Generate Operation Plan* command from the Command Manager or the SOLIDWORKS CAM NC Manager level, then operations will be generated for all prismatic features in the tree, regardless of the active item in the tree.
- If you execute the *Generate Operation Plan* command from the Mill Part Setup level, then operations will be generated only for those prismatic features listed under the given Mill Setup.
- If you execute the *Generate Operation Plan* command at the feature level (by right-clicking on a feature listed in the Feature tree and executing *Generate Operation Plan* command from the RMB context menu), then operations will be generated only for the selected feature.

SOLIDWORKS CAM generates the operation plan for all the machinable features in *Mill Part Setup1*. The operations are listed in the SOLIDWORKS CAM Operation tree, which displays automatically. The Operation tree can also be accessed by clicking the SOLIDWORKS CAM Operation Tree tab.

The SOLIDWORKS CAM Operation tree provides an outline view of the operations for the machinable features. Operations are listed under the Mill Part Setup in the same order as the machinable features. At the top of the tree is the SOLIDWORKS CAM NC Manager. The Stock Manager and Machine items are the same as in the SOLIDWORKS CAM Feature tree. You can change the stock size and shape and the post processor used by SOLIDWORKS CAM to produce G-code.

The SOLIDWORKS CAM Operation tree allows you to:

- Insert, rename, suppress, and delete operations
- Change operation parameters
- Combine operations
- Sort operations
- Change the machining order
- Generate toolpaths
- Simulate toolpaths
- Post process the toolpaths
- Hide or show toolpath display
- Search based on item name

To the left of each toolpath operation is a plus sign (+). Clicking a plus sign displays the name of the Machinable Feature that this operation is going to machine. These Machinable Feature items can be used to view geometric information and to modify the machining depth of the feature.

The operations that are generated by SOLIDWORKS CAM are based on information stored in the Technology Database. These operations are intended to be used as a starting point. Each operation contains operation parameters that affect how the toolpath is created and specific parameters that will be output to the NC program. These parameters can be edited before generating the toolpaths and post processing the part.

### **Exclamation mark symbol over certain operations**

In the Operation tree, observe that *Center Drill1* and *Drill1* operations have an exclamation mark over them. The exclamation mark serves as a potential warning. In most cases, the exclamation mark indicates that no suitable tool was available in the active tool crib to machine that particular feature and hence a suitable tool was added from the tool library and assigned to the operation.

Following are the steps to get rid of the exclamation mark:

- Right-click on the *Center Drill1* operation with an exclamation mark and select *What's wrong?* from the context menu.
- A warning message indicating that tool selected was not from the active tool crib will be displayed.
- Click on the *Clear* button in this dialog box to get rid of the exclamation mark.
- Repeat above steps for all operations with the red exclamation mark. In this tutorial, repeat this step for *Drill1* operation.

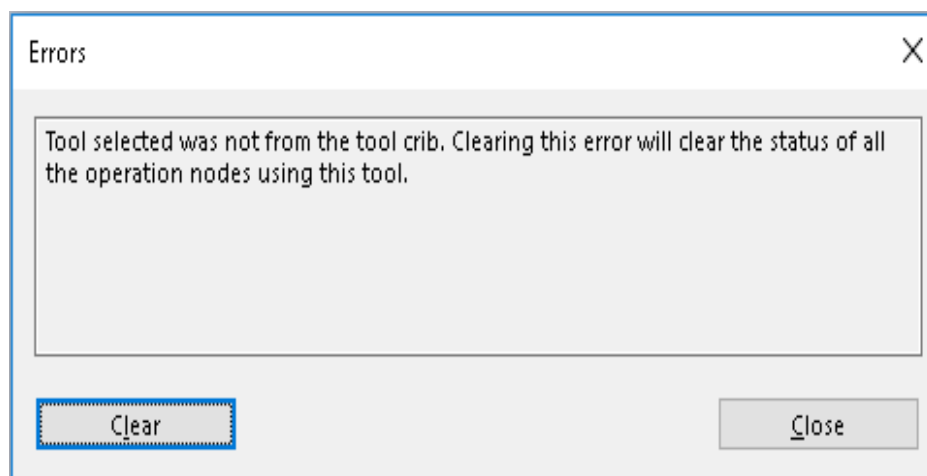

**Message indicating What's wrong with the selected Operation**



### ***Did You Know ...***

If an operation displays in a color other than black, then it indicates that toolpaths have not been generated for that particular operation. This occurs when you insert a new operation interactively, you insert a new feature interactively and generate operations for the new feature, or SOLIDWORKS CAM cannot generate the toolpath for an operation because of an error in the toolpath algorithm or a parameter is not correct. You can set the color for operations without toolpaths on the Display tab in the Options dialog box.

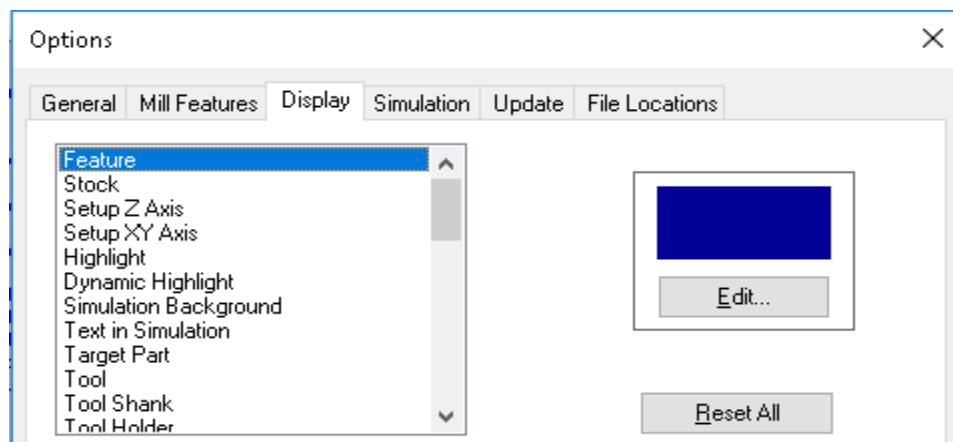

**Display tab of Options dialog box**

## ***Generate Toolpath Command***

Click the *Generate Toolpath* button on the SOLIDWORKS CAM Command Manager.

OR

Right click *Mill Part Setup1* in the SOLIDWORKS CAM Operation tree and select *Generate Toolpath* command on the context menu.

SOLIDWORKS CAM calculates the toolpaths for each operation in the Mill Part Setup.

### **Note:**

Just like the Generate Operation Plan command, the scope of the Generate Toolpath command too depends from which level the command is executed.

- Executing the *Generate Toolpath* command from the SOLIDWORKS CAM NC Manager level generates toolpaths for all the operations.
- Executing the *Generate Toolpath* command at Mill Part Setup level generates toolpaths only for operations listed under the given mill setup.
- You can also generate toolpaths for each operation individually by right-clicking on an operation and executing *Generate Toolpath* command on the context menu.

1. Highlight the first operation in the Operation tree, hold down the *Shift* key, then highlight the last operation.  
This action displays the toolpaths for all the operations on the part (in the graphics area) showing the centerline of the toolpath.
2. Click an operation in the SOLIDWORKS CAM Operation tree.
  - The toolpath for that operation is displayed.
  - As you click each operation, the toolpath for that corresponding operation is displayed.
  - Generated toolpath list is displayed in the Operation tree.

## Step 7: Adjusting Toolpath Parameters

SOLIDWORKS CAM calculates toolpaths using the operation parameters and the feature's size and shape. After toolpath is generated for a particular operation, then that operation is displayed in black-colored font in the Operation tree. These parameters can be edited after generating the toolpaths and before post processing the part.

### Edit toolpath parameters:

1. In the Operation tree, click on the '+' sign next to *Rough Mill5* operation. The feature for which the operation was generated is listed below it. Observe that this operation was generated for *Irregular Pocket2* feature.
2. Double click *Rough Mill5* operation.

OR

Right click on *Rough Mill5* and select *Edit Definition* on the context menu.

The *Operation Parameters* dialog box will be displayed whenever you double-click or execute *Edit Definition* command for an operation in the Operation tree. This dialog box gives you access to all the parameters used to define the toolpath.

General parameters for the type of toolpath include the method of machining, depth of cut, step over, stock allowance, retract height, speeds and feeds. This dialog box also gives you access to the parameters for the tool you are using and allows you to select a different tool.

3. Click the *Roughing* tab and change the Pocketing Pattern to *Zigzag*.



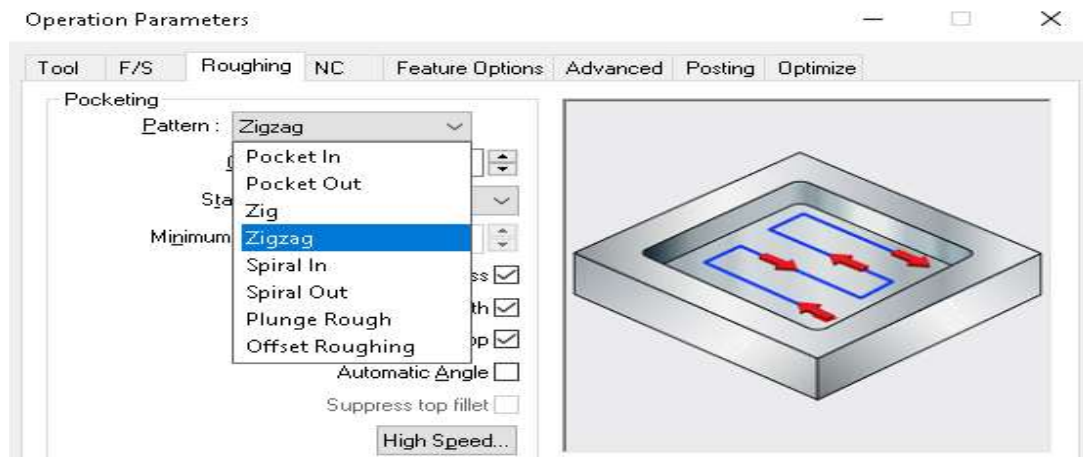

**Roughing tab of Operation Parameters dialog box**

4. Click the *Feature Options* tab. In the *Entry* group box, change the *Method* to *Entry Hole*.
5. Click *OK* to close the dialog box.
6. Observe the SOLIDWORKS CAM Operation tree. Notice that the *Center Drill2* and *Drill2* operations were created automatically above the *Rough Mill5* operation since you set the *Entry Method* to *Entry Hole*.

When using the Entry Hole method, control is provided to:

- Specify any number of machining processes in the Technology Database to machine the entry hole (i.e. Center Drill and Drill).
- Tool type selection is based on what each operation supports.
- Tool diameter selection can be customized in the Technology Database.
- Operation parameter defaults can be defined in the Technology Database.

### **Simulate Toolpath**

SOLIDWORKS CAM provides the ability to simulate the toolpath showing the tool movement and the resulting shape of the part.



1. Right click on *Mill Part Setup1* and select *Simulate Toolpath* from the context menu. The Toolpath Simulation dialog box is displayed.

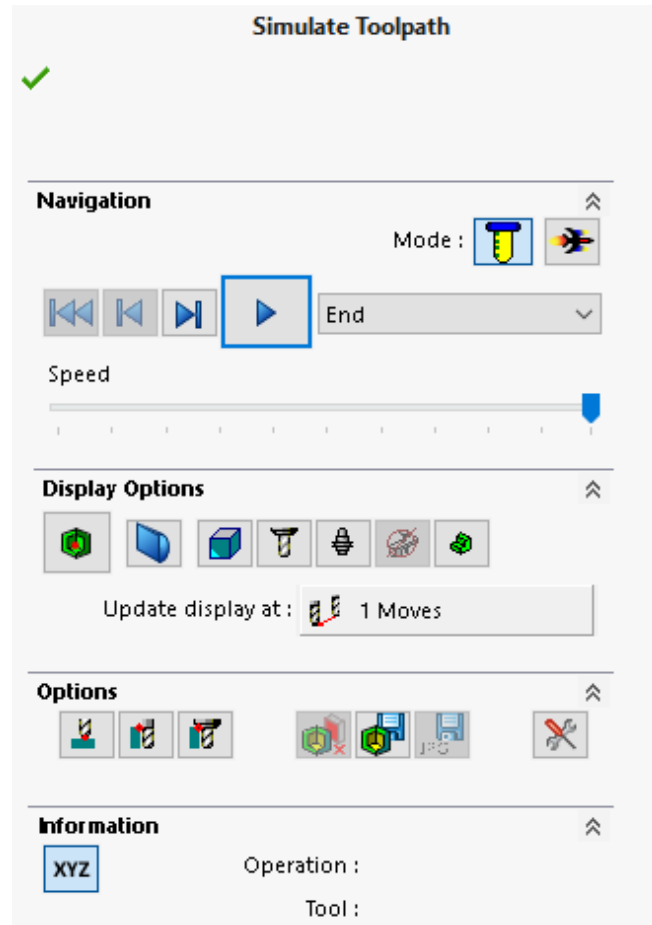









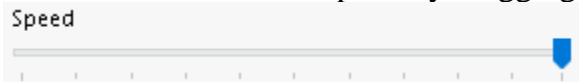



**Simulate Toolpath Dialog box**

The toolbar controls allow you to:

- Run the simulation in  *Tool* or  *Turbo* mode.
- Display the simulated part, the design part and a comparison of the two by clicking on the *Show Difference* button .
- Customize the display of the stock, tool and tool holder (*wireframe*, *translucent*, *shaded*, or *no display*) in *Tool* mode.  
Note that these options are disabled in *Turbo* mode.
- Run the simulation for all or selected operations.
- When simulating an operation, the simulation can be for the current operation or for all previous operations up to the selected operation.
- Dynamically change the orientation of the part using zoom, pan, rotate, etc.
- Control the simulation speed by dragging the Simulation Speed Control slider



If you want to simulate only the toolpath for a given operation, you can right click on that operation and select *Simulate Toolpath* in the context menu.

2. Set the simulation mode to *Tool mode* by clicking on the *Tool mode* button .
3. Set the tool display as *Shaded With Edges* .
4. Set the Tool Collision, Tool Shank Set the tool holder display as *Tool Cut Collision, Tool Shank Cut Collision and Tool Holder Cut Collision*   .
5.  Click the *Run* button.  
The simulation runs in *Tool mode* with the tool and holder displayed during simulation.
6. Click the *Pause* button  to pause during simulation. Click the *Run*  button to continue simulation.
7.  Click the button in the upper right corner to cancel or close the simulation.

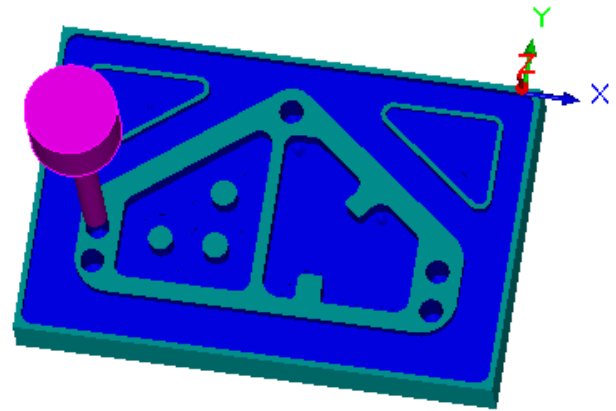

**Simulation Mode**

## Step Through Toolpath

SOLIDWORKS CAM also provides the ability to visualize the tool motion and verify tool positions using the Step Thru Toolpath command.

1. **Executing the Step Thru Toolpath command:** Both the *Simulate Toolpath* and *Step Thru Toolpath* commands can be executed at the global, setup and operation levels.

**Global level:** To step through the toolpaths of all the operations in the Operation tree, right click on the *SOLIDWORKS CAM NC Manager* in the Operation tree and select *Step Thru Toolpath* command in the context menu.

OR

Select *Step Thru Toolpath* command on the Command Manager.

**Setup Level:** Right-click on the *Mill Part Setup1* and select *Step Thru Toolpath* command in the context menu.

**Operation level:** Right-click on the desired operation in the Operation tree and select *Step Thru Toolpath* in the context menu.

On execution of the Step Thru Toolpath command using one of the above methods, the *Step Thru Toolpath* dialog box is displayed. On execution

2. Use controls given in the *Display Options* group box to set the options as to how the toolpath will be displayed during the Step Through process.

3. In the *Play Tool Until* dropdown list, leave the end condition set to the default *End*.
4. Use the *Animation speed* slider to adjust the animation speed.

5. Click the *Play* button  to continuously back-plot the tool till the end condition specified in the *Play Tool Until* field is reached.

6. During animation, the *Play* button display changes to *Pause* button . Click the *Pause* button to pause the animation while it is in progress.

7. When the animation has not yet begun or when it is paused, the *Forward Single Step*, *Goto End of Current Toolpath* and *Goto End* buttons are active.

- Use the *Forward Single Step* button  to move one toolpath record forward each time the button is clicked.



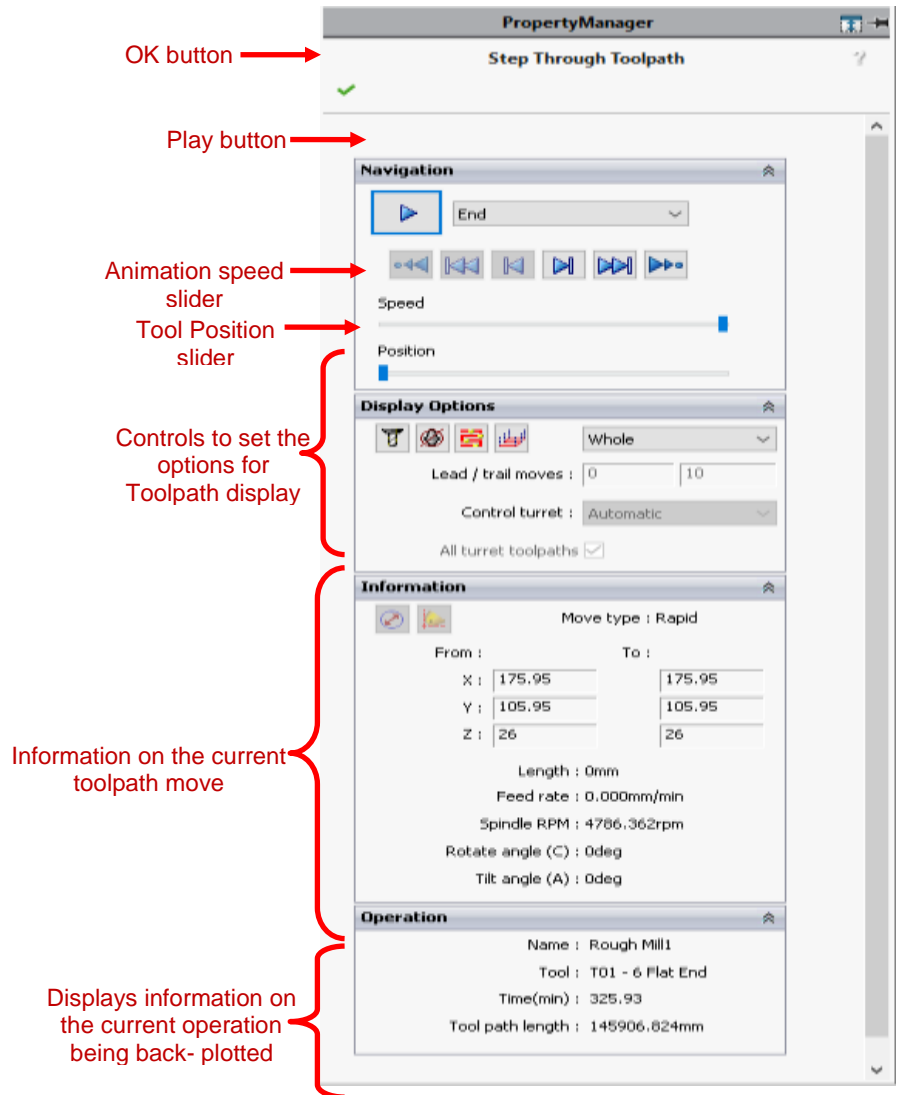

- Use the *Goto End of Current Toolpath* button  to move the tool position to the last toolpath record of the current operation.

- Use the *Goto End* button  to move the tool position to the last toolpath record of the very last operation.



**Step Through Toolpath dialog**

**Note:** The last operation varies depending on which level the Step Through Toolpath command is executed from. For example, if this command was executed from the Mill Setup level, then the last operation would be the last operation under that particular setup.

8. When the animation has been completed or when it is paused, the *Reverse Single Step*, *Goto Start of current Toolpath* and *Goto Start* buttons are active.
  - Use the *Reverse Single Step* button  to move one toolpath record backwards each time the button is clicked.
  - Use the *Goto Start of Current Toolpath* button  to move the tool position to the first toolpath record of the current operation.
  - Use the *Goto Start* button  to move the tool position to the first toolpath record of the very first operation.
9. If you are unsure about the use of any parameter within this dialog box, click on the *Help* button  at the upper right corner. This action will display the context-based help for Step Through Toolpath command.
10.  Click the *OK* button in the upper left corner to close the dialog box.

## Step 8: Post Process Toolpaths

Post processing is the final step in generating the NC program file. When you use a SOLIDWORKS CAM internal post processor, this step translates generalized toolpath and operation information into NC code for a specific machine tool controller. SOLIDWORKS CAM creates NC code for each toolpath in the order the operation appears in the SOLIDWORKS CAM Operation tree. When you post process a part, SOLIDWORKS CAM creates two files: the NC program and the Setup Sheet. These are text files that you can read, edit and print using a word processor or text editor.



### **Did You Know ...**

**For more information on generating an enhanced APT CL file that can be used by external post processing programs, see the context-based Help.**

In this tutorial, you will post process all the operations and generate the NC program:

1.  Click the *Post Process* button on the SOLIDWORKS CAM Command Manager.
- OR

Right click on the *SOLIDWORKS CAM NC Manager* in the Operation tree and select *Post Process* on the context menu.

The *Post Output File* dialog box is displayed so that you can save the NC program file.

Typically, the NC program and Setup Sheet files are stored in the folder that contained the last part that was opened. If you want these files in another location, you can change the folder location.

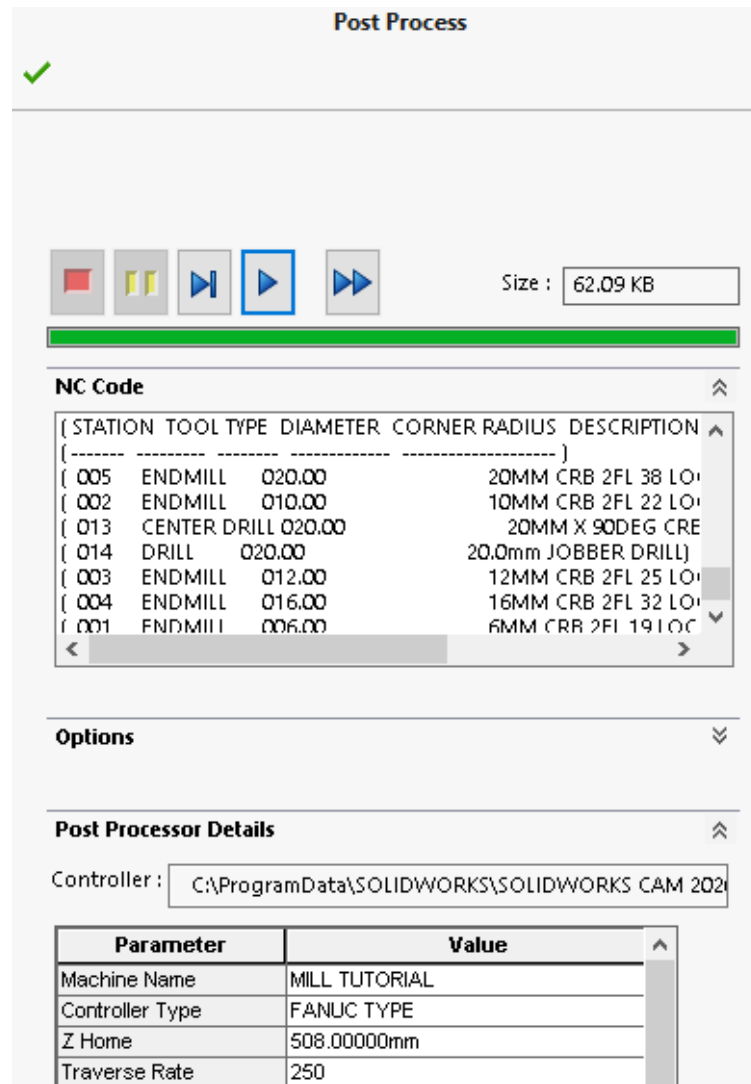

**Post Process dialog box**

**Note:** If the **Post Process** command is grayed out on the **SOLIDWORKS CAM Command Manager** or on any context menu, make sure that you have selected a post processor and generated the toolpaths. Refer [instruction 4 of Step 3](#) in this tutorial.

- In the *Post Output File* dialog box, click the down arrow to the right of the *Save as type* box. SOLIDWORKS CAM provides a list of commonly used extensions that you can select. For this exercise, use the *.txt* extension.



**Did You Know ...**

If you want change the default extension from .txt to one of the ones in the list or if you want a different file name extension for NC program files, you can edit or create a .pinf file and specify the new extension. For more information on making these changes, see the context-based Help.

3. In the *File name* textbox, type the suitable file name, and then click *Save* button.
4. The *Post Process Output* dialog box will be displayed. Click the *Step* button  on the control bar at the top.

SOLIDWORKS CAM starts to generate the NC program and the first line of NC code displays in the NC code output view box. The post processing mode is set to post process one line of code at a time (Step mode).

5. Click the *Step* button. The next line of NC code is displayed.
6. Click the *Run* button . Post processing continues until it is completed.
7. When the post processing is finished, view the code using the vertical scroll bar.
8. Click *OK* to close the dialog box.

**More About Setup Sheets**

The Setup Sheet is a printable file that contains information the machine tool operator can use to set up the part and the tools required to produce a part. The information includes the machine, the controller, estimated machine time, the part material, and the tooling used to machine the part.

SOLIDWORKS CAM provides two methods for creating Setup Sheets:

- i. During post processing, SOLIDWORKS CAM automatically creates a simple text file with a .set extension.

- ii. The Setup Sheet command on the *SOLIDWORKS CAM NC Manager* context menu and the *Generate Setup Sheets* command on the *Setup* context menu. In the *Setup Sheet Options* dialog box, the information is

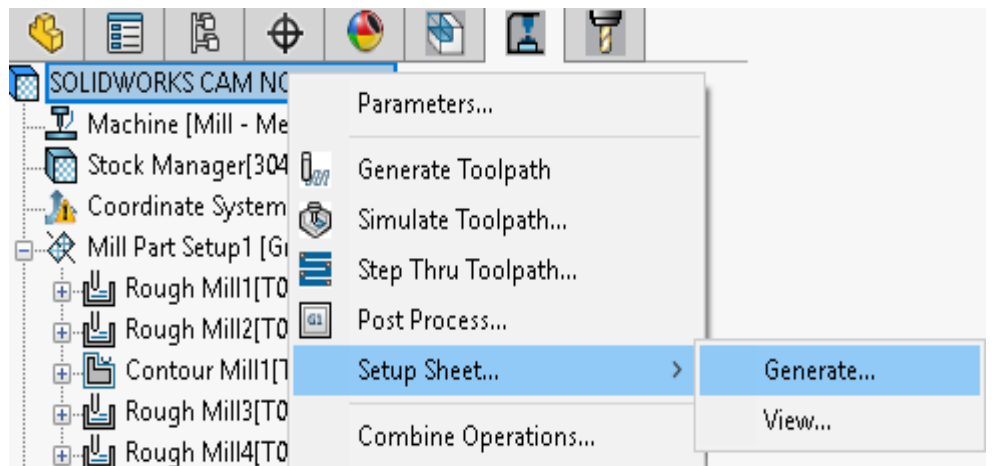

**Generating Setup Sheets**



saved in an XML file, which allows the Setup Sheet to be formatted with an HTML style sheet and displayed in a web browser.

## 2 Axis Mill 2

### Topics covered in this tutorial:

SOLIDWORKS CAM is a feature-based machining system. Feature-based machining provides numerous benefits because the definition of the feature enables a higher level of automation when creating machining operations and associated toolpaths. Adding to this benefit, SOLIDWORKS CAM provides one method for extracting features:

- **INTERACTIVE FEATURE RECOGNITION**

An interactive method for inserting features using the *New 2.5 Axis Feature* or *New Multi Surface Feature* function. .

The following tutorial demonstrates how some of the features are identified automatically using the *Extract Machinable Features* command.

### Extracting and Working with Machinable Features

1. Open the part file **MILL2AX\_2.SLDPRT** in the folder.

*C:\Users\Public\Public Documents\SOLIDWORKS\SOLIDWORKS 201x\CAM Examples\Tutorial\_Parts\Mill*

2. Examine the part. You can recognize various sizes and shapes of holes, bosses, pockets and slots. It appears that SOLIDWORKS CAM extracts features based on SOLIDWORKS features used to create the part. As you will see, this is not necessarily so. Notice that the design tree contains no design features. This part was imported into SOLIDWORKS.

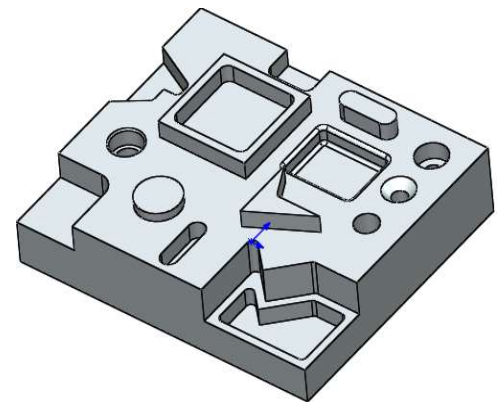

**MILL2AX\_2.SLDPRT**

In this tutorial, you will see how SOLIDWORKS CAM determines machinable features.

3. Click the *SOLIDWORKS CAM Feature Tree* tab.

4.  Double click *Machine [Mill-Inch]* in the SOLIDWORKS CAM Feature tree.



#### **Did You Know ...**

**In the SOLIDWORKS CAM Feature and Operation trees, instead of right-clicking on the listed items and selecting Edit Definition from the context menu, you can double-click the item to open the dialog box for editing the Stock Manager, Machine, Setups, Features and Operations.**



The *Machine* dialog box will be displayed. This dialog box allows you to select a machine definition, tool crib and post processor. On the *Machine* tab of this dialog box, *Mill-Inch* is the active machine. This machine definition has been created for the SOLIDWORKS CAM tutorials.

## Tool Crib Tab

When you use SOLIDWORKS CAM to machine your own parts, you need to select the machine tools that you want to use to machine the part.

Click on the *Tool Crib* tab. This tab allows you to choose a tool crib or set of tools that are used with the machine you have chosen. The Tool crib does not contain all the tools that are available; rather it contains a subset of tools that you can modify to represent the actual set of tools that is loaded on the machine.

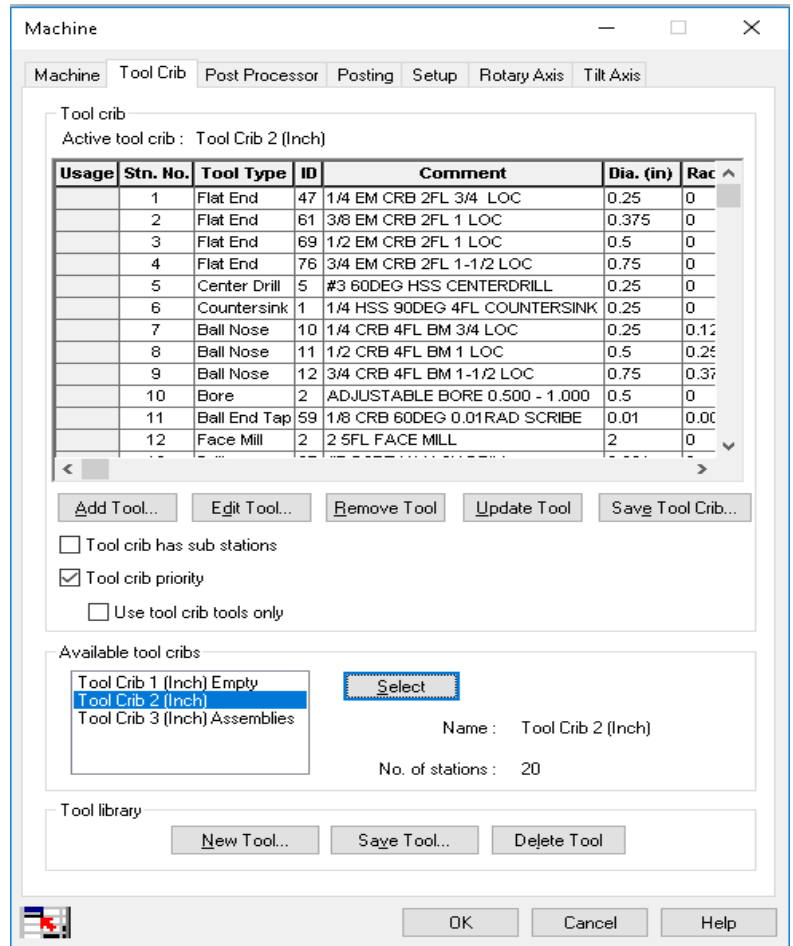

**Tool Crib tab of Machine dialog box**

## Tool Crib Priority

If you select the *Tool crib priority* option, tool selection rules are modified to place a higher priority on selecting tools from the tool crib. This results in fewer tools being added to the tool list from the tool library. Refer to the [SOLIDWORKS CAM Context-based Help](#) to understand the rules that are observed when this option is used. For this tutorial, leave the *Tool Crib priority* option check box checked.

## Tool Crib has Sub Stations

Select this option if your machine supports gang tooling. In this tutorial, this option will be left unchecked.

## Editing the Tool Crib

You can add, remove and edit tools in the Active Tool Crib from the *Tool Crib* tab.

1. Make sure *Tool Crib 2 (Inch)* is the active tool crib.

- Highlight a tool in the Active tool crib list and click *Edit Tool* button.  
The *Edit Tool Parameters* dialog box will be displayed.

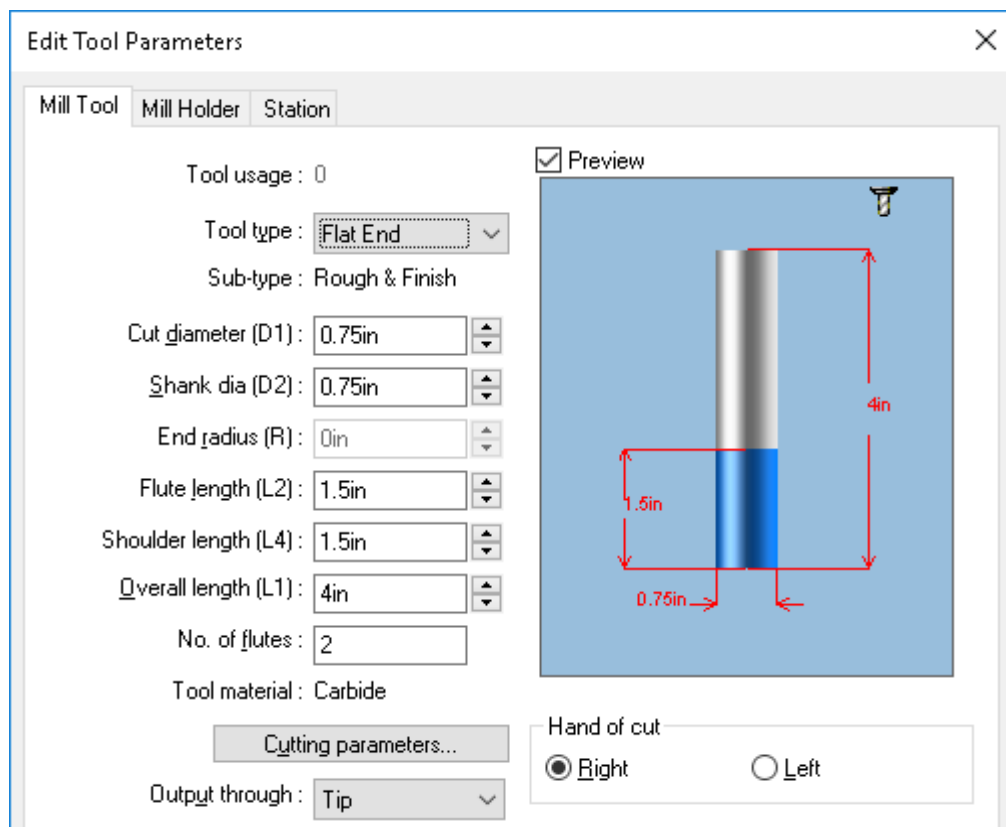

**Edit Tool Parameter Dialog box**

This dialog box allows you to change the parameters for the selected tool. The changes you make in this dialog box affect only the tool crib for the current part. To change the tool definition for all future jobs, click the *Save Tool Crib* button on the Tool Crib tab or edit the tool crib definition in the Technology Database.

- Click *OK* to apply the changes and close the *Edit Tool Parameters* dialog box. Click *Cancel* to close this dialog box without saving the changes. In this tutorial, no changes have been done to the parameters of an tool in the Tool crib. Hence, click *Cancel*.
- To add tools from the tool library to the active Tool crib, click the *Add Tool* button below the *Tool crib* tab in the *Machine* dialog box.

The *Tool Select Filter* dialog box will be displayed. This dialog box allows you to set filters for displaying and selecting tools. At the bottom of this dialog box is a form listing all the existing tools in the Technology Database which meet the filter criteria.

- Select the required filters and enter the corresponding range values in the provided fields. Click *OK*.

6. To add a tool from this list into the active tool crib, highlight the required tool and click *OK*.

The tool will be added at the bottom of the active tool crib. To make this tool available in the active tool crib for all future jobs, click on the *Save Tool Crib* button.

**Note:** You cannot use the **Tool Select Filter** dialog box to add new tools to the **Technology Database**. This dialog box can only be used to add tools to the **active tool crib**.

7. Click *Cancel* to close the *Tools Database* form without adding a tool to the active tool crib.

	ID	Tool ID	Min Bore Dia	Max Radius Cut Depth	Radius Adjust Range	Effec Cut Len	0
1	1	BRS-0.040-0.500	0.040000	0.010000	0.500000	0.200000	4.
2	2	BRS-0.500-1.00	0.500000	0.010000	1.000000	0.200000	4.

**Tool Select filter dialog box**

### **Modifying the Tools in the Technology Database**

You can add, edit and delete tools present in the Technology Database using the Tool Library buttons provided in the *Tool Crib* tab of the *Machine* dialog box.

## Adding a New Tool

To add a new tool to the Technology Database, click on the *New Tool* button in the *Tool Crib* tab. The *New Tool* dialog box is displayed. Assign tool parameters as desired. Click *OK* to close the *New Tool* dialog box. Observe that the new tool is added to the Active Tool crib list. The tool is also added to the Technology Database.

## Saving Changes Made to a Tool in the Active Tool Crib

If you edit a tool listed in the *Active tool crib* list, then the changes are applicable for the current part only. These changes can be made permanent (and thus available for future machining jobs) by saving them to the Technology Database. To do so, highlight the tool in the *Active tool crib* list and click on the *Save Tool* button. The SOLIDWORKS CAM displays the *Save to Database* dialog box. In the *Save Tool to TechDB* group box within this dialog box, you can choose to update the existing tool or save the tool as a new tool within the database. Select *Update tool* checkbox to save the changes to the existing tool. Select *Add new tools to database* to save the edited tool as a new tool.

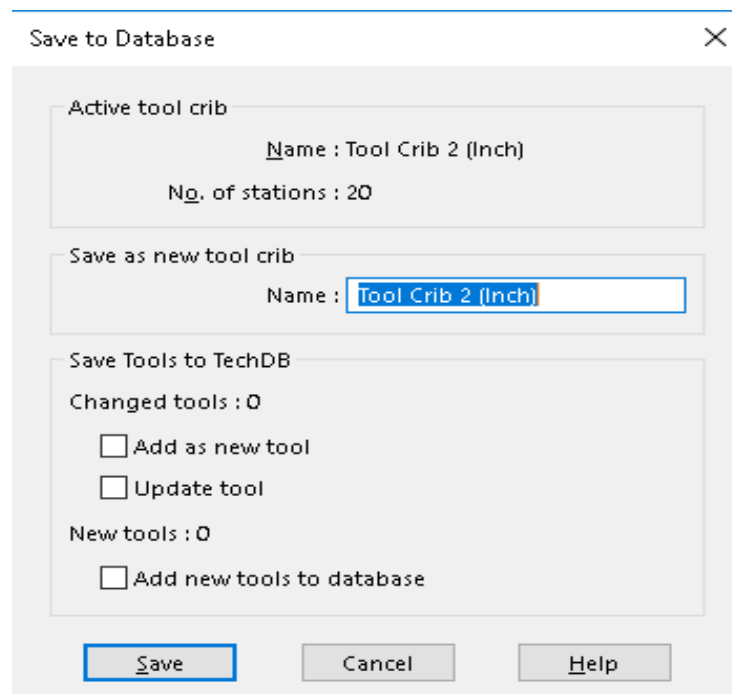

**Message displayed on clicking the 'Save Tool' button**

## Deleting a Tool

To permanently delete a tool from the Technology Database, highlight the tool in the *Active tool crib* list and click on the *Delete Tool* button. This action will remove the tool from the Technology Database. However, the tool will still be visible in the Active tool crib list for the current part. To remove it from the *Active tool crib* list, highlight the tool in the list and click on the *Remove tool* button.

## Post Processor Tab and Posting Tab

1. Click the *Post Processor* tab in the Machine dialog box and make sure *M3AXIS-TUTORIAL* is selected.

The *M3AXIS-TUTORIAL* post processor is used for the exercises in this manual.

When you use SOLIDWORKS CAM to machine your own parts, select your machine tool controller or post processor.

2. Click the *Posting* tab.

These parameters provide information required to generate the NC program. When you use SOLIDWORKS CAM to machine your own parts, change these parameters as required.

3. Click *OK* to close the *Machine* dialog box.

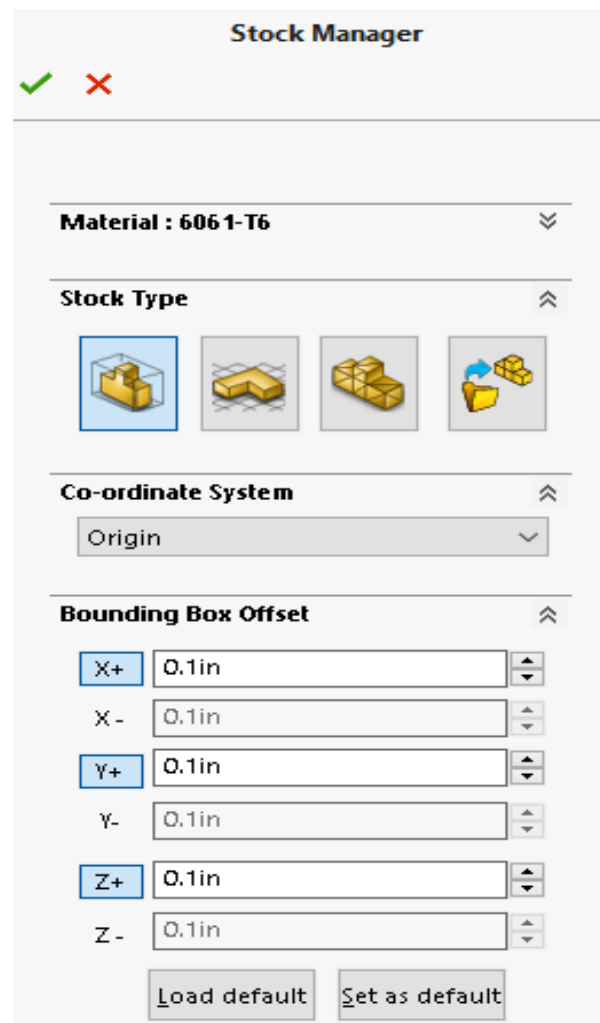

**Setting Bounding Box offsets in Stock Manager Dialog Box**

## Defining the Stock

1. Double click *Stock Manager* in the Feature tree.
2. The *Stock Manager* dialog box is displayed. Leave the *Stock Type* set to default *Bounding box*.
3. Change the Bounding box offsets to a uniform **0.1in** for X, Y, and Z.
4. Click *OK* to apply the changes and close the dialog box.

## Extract Machinable Features

1. Click the *Extract Machinable Features* button on the SOLIDWORKS CAM Command Manager.

The *SOLIDWORKS CAM Message Window* is displayed. This window reports the process status and shows the progress of the process.

When AFR is finished, the SOLIDWORKS CAM Feature tree displays the machinable features.

From the tree, you can reorder features using drag and drop, change feature names and suppress features.

2. Click each machinable feature in the SOLIDWORKS CAM Feature tree.

As you pick each machinable feature, the geometry for that feature highlights on the part.

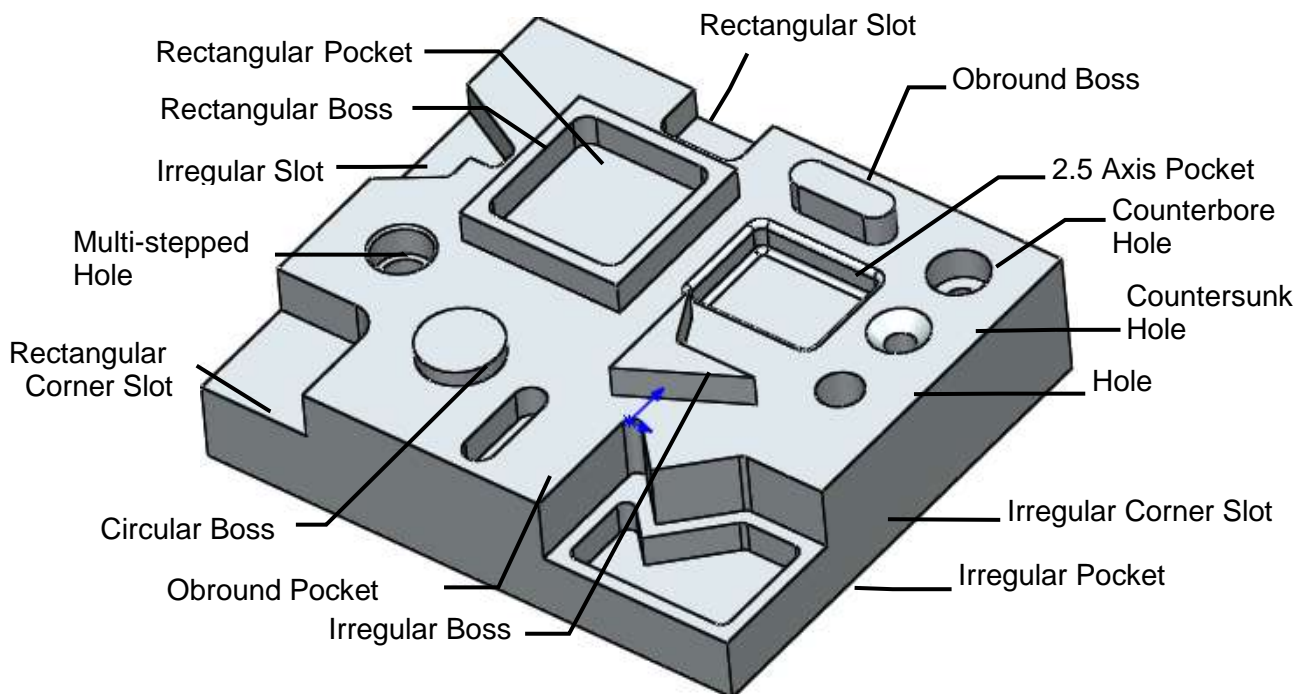

### 2.5 Axis Mill Features

Notice that an Open Pocket feature was created.

When SOLIDWORKS CAM creates a Mill Part Setup, an Open Pocket feature is created automatically if AFR finds a boss feature and the Setup is parallel to one of the sides of the stock. The bottom of the Open Pocket is the bottom of the Boss feature and the boss becomes an island in the Open Pocket.

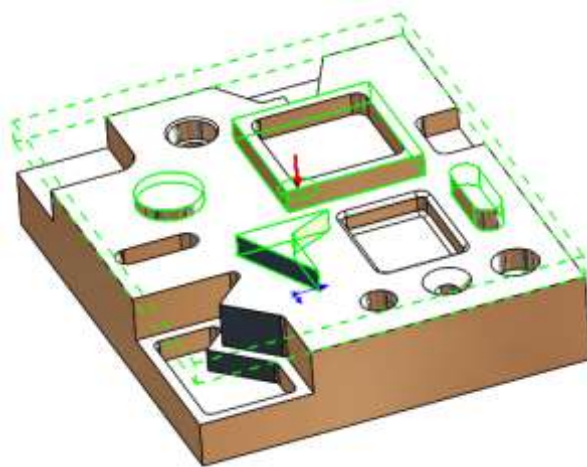

**Open Pocket Feature with boss features as islands**

### Setting Feature Types to be recognized by AFR

- Click on the SOLIDWORKS CAM *Options* button in the SOLIDWORKS CAM Command Manager.  
The *Options* dialog box is displayed.
- Click on the *Mill Features* tab. The defaults in the *Feature types* group box are set for SOLIDWORKS CAM to recognize and create *Holes*, *Non holes*, *Boss* and *Tapered and filleted* features.

- In the *Feature types* section, check the *Face* option.

If the *Face* option is checked, then a *Face Feature* is created automatically when the *Extract Machinable Features* command is executed and is listed under the *Mill Part Setup* if the top most face is parallel to the *Setup* and the *Setup* is parallel to one of

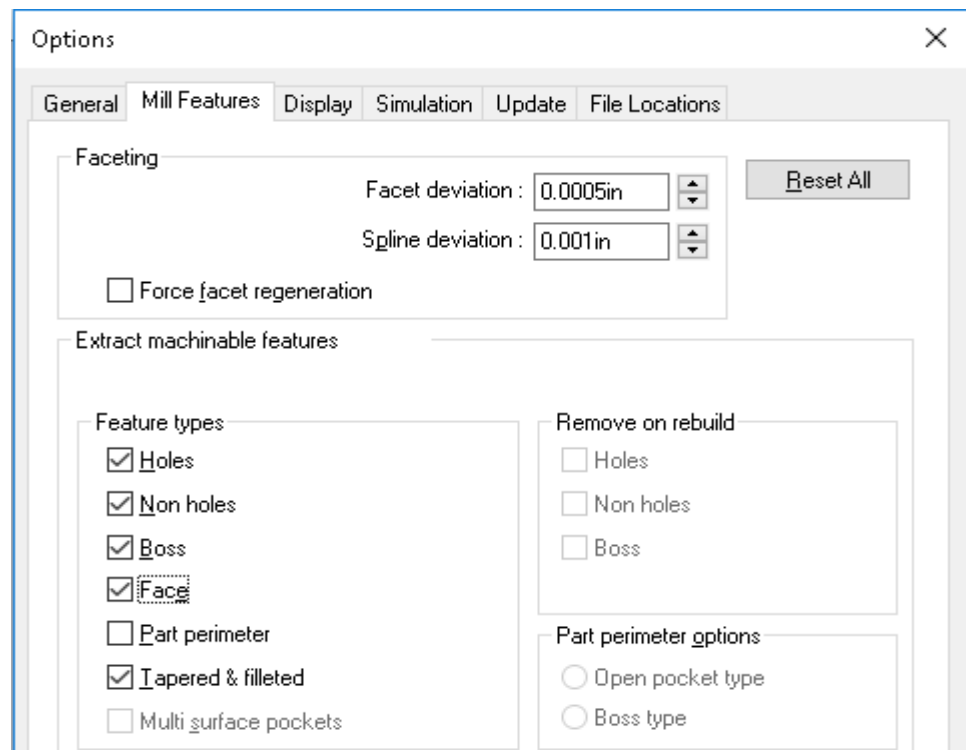

**Selecting Feature Types to be recognized by SOLIDWORKS CAM when EMF command is executed**



the sides of the stock.

4. When SOLIDWORKS CAM extracted features, a 2.5 Axis pocket (*Rectangular Pocket2*) was found. This feature was recognized because the *Tapered & filleted* option in the *Feature Types* group box was checked. When the *Tapered & filleted* option is checked, SOLIDWORKS CAM can automatically create 2.5 axis features that meet the definition of filleted and tapered features which fulfill the following conditions:

- The top and bottom of the feature are flat and parallel to the Mill Part Setup direction.
- The side wall can be vertical or a constant taper with a top or bottom fillet and/or a top of bottom chamfer.
- Corner fillets must be conical as defined by the taper angle of the feature.

**Note:** Tapered and filleted features which do not fulfill the above conditions are not recognized automatically by AFR when the EMF command is executed. Such features can be created interactively using the New 2.5 Axis Feature command.

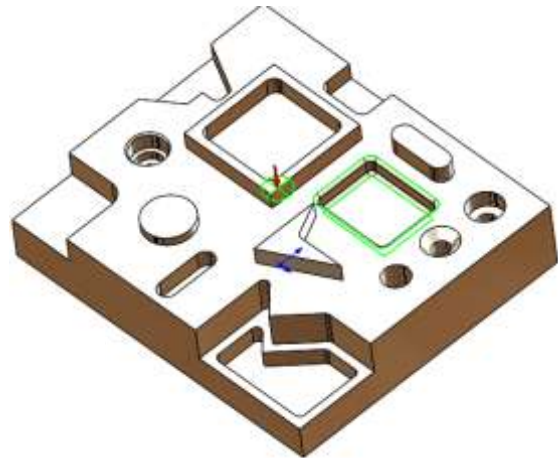

**Tapered & filleted rectangular pocket  
(highlighted in green)**

### **Rebuild the Features**

Now that the Face Feature option has been checked within the list of Features Types to be recognized, you need to execute the *Extract Machinable Features* command once again to rebuild the features.

1.  Click the *Extract Machinable Features* button on the SOLIDWORKS CAM Command Manager.
2. SOLIDWORKS CAM rebuilds the feature list. Observe the SOLIDWORKS CAM Feature tree. Notice that AFR has created a Face feature.



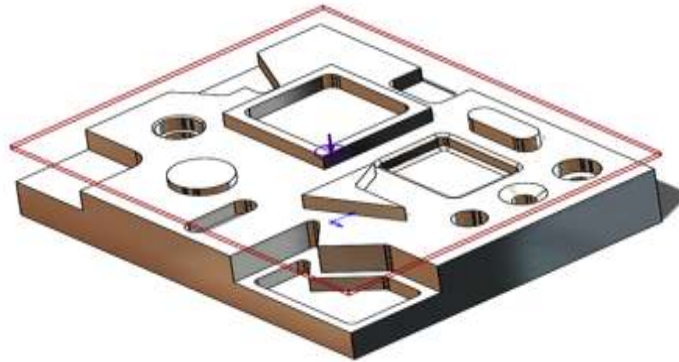

**Face Feature (highlighted in Red)**

### Setting Feature Strategy

Machinable features are recognized based on the part's geometry (the shape of a feature) and topology (how the features are related to one another). However, not all strategies of a feature can be determined from the geometry and topology.

For example, Automatic Feature Recognition (AFR) cannot determine whether a hole has been threaded, reamed or bored. SOLIDWORKS CAM allows you to specify an additional Strategy to a feature so that more appropriate operations can be created.

Following are the steps to specify the strategy:

1. Double click *Hole1* in the Feature tree.

The *Parameters* dialog box will be displayed. This dialog box provides a geometric and dimensional report on the feature and allows you to assign additional information to the feature. In the case of holes, you can identify whether the hole is to be drilled, bored, reamed or threaded, etc.

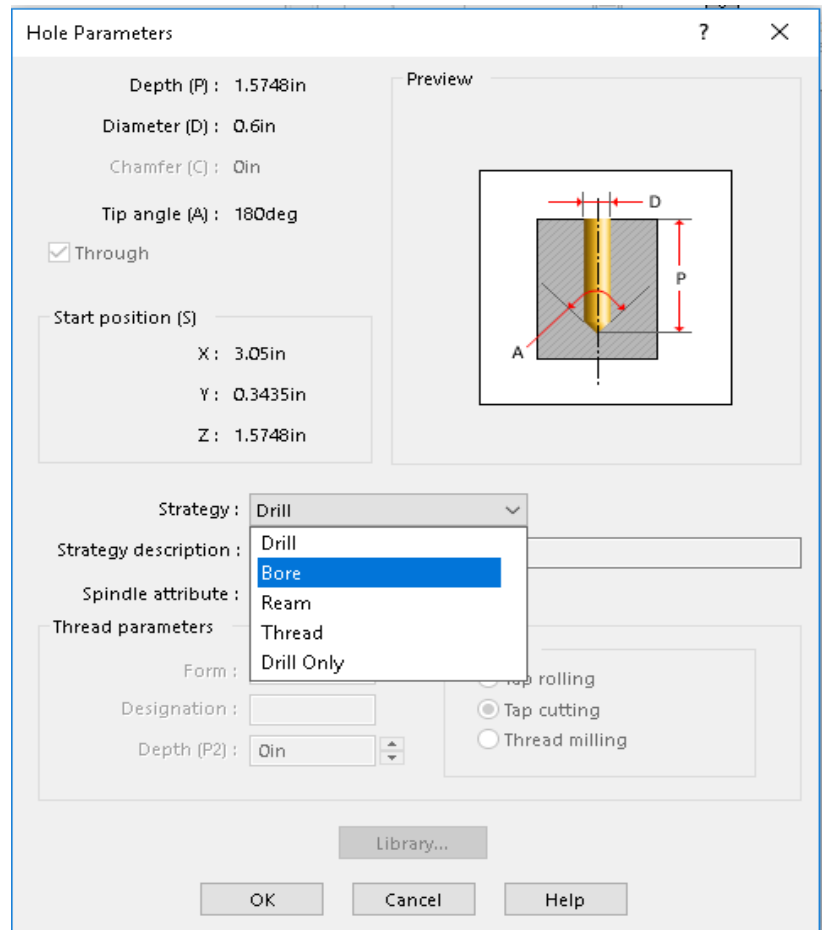

**Hole Parameters dialog box**

Depending on the *Strategy* selected, a different machining process can be assigned. You can change how each feature is processed by defining the sequence in the Technology Database.

2. In the *Strategy* dropdown list, select *Bore*.
3. Click *OK* to apply the changes to Strategy and close the dialog box.
4. Review the parameters of other machinable features to understand more about the features.

## Mill Part Setup

During Automatic Feature Recognition, the *Extract Machinable Features* command also created *Mill Part Setup1*. The Mill Part Setup defines the tool direction necessary to machine these features.

1. Click *Mill Part Setup1* in the Feature tree.

A marker displays on the part. The arrow indicates the machining direction. The cross in the center of the circle represents the machining X and Y axes. The X machining direction can be changed if necessary. For more information, see the [SOLIDWORKS CAM context-based Help](#).

The origin of the Mill Part Setup is program zero. By default, the origin is set to a vertex or middle of the top most features. In most situations, you will want to change this.

How to change the Mill Part Setup origin is explained in [Chapter 3](#) of this document.

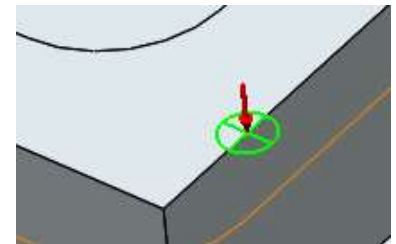

Marker displayed on part

## Generate Operation Plan

When you execute the *Generate Operation Plan* command, operations are created for every selected feature based on the rules defined in the Technology Database (TechDB). Operations are not generated for suppressed features and features in the Recycle Bin.

In this tutorial, you will first create an operation plan for an individual machinable feature and then for all machinable

features within the Mill Part Setup.

1. Right click on *Rectangular Pocket1* and select *Parameters* on the context menu.
2. The *Rectangular Pocket Parameters* dialog box is displayed. In the Strategy dropdown list, select *Coarse*.

*Coarse* is a system Strategy that has been defined in the TechDB to generate a Rough Mill operation for a Rectangular Pocket feature. Details of the Rough Mill operation designated to this strategy will be displayed to the right hand side of the dialog box when you select the Strategy in the dropdown list. After you have learned how to use

SOLIDWORKS CAM, you can modify system Strategies to correspond to your requirements.

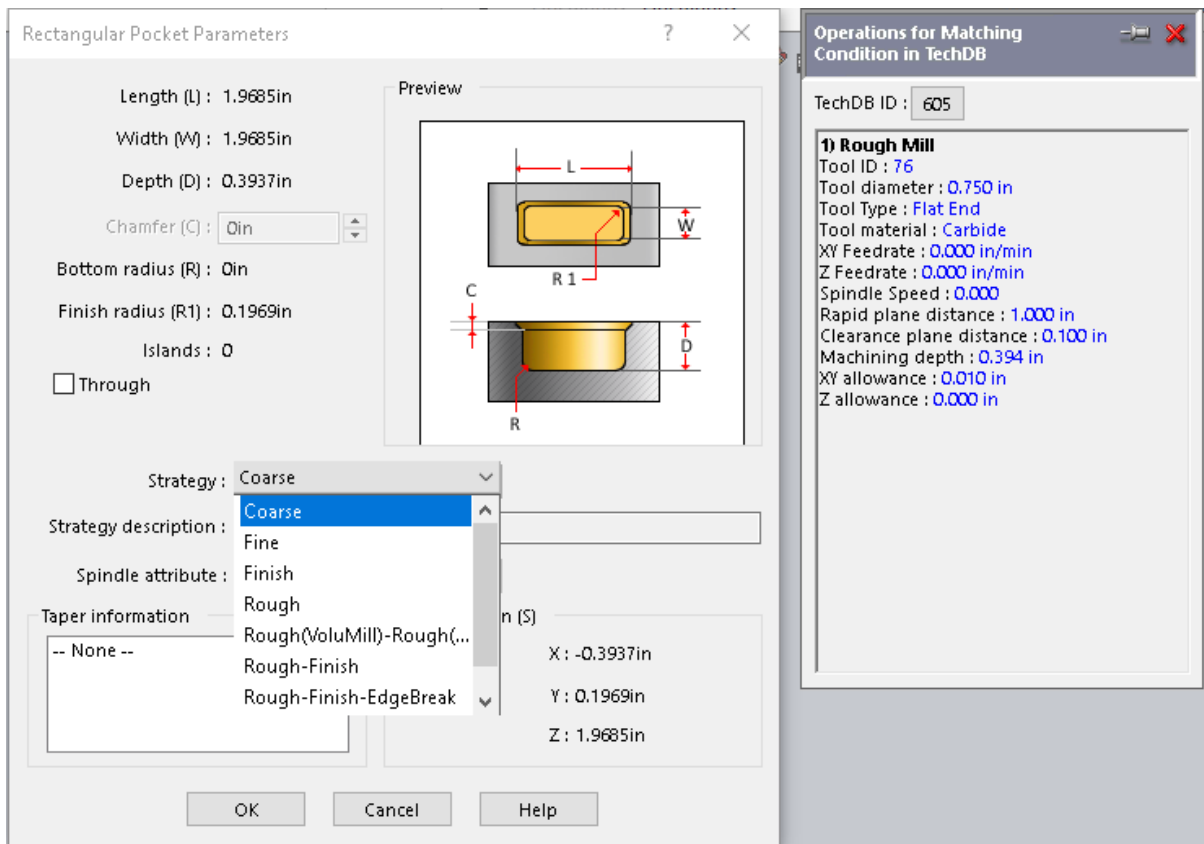

**Strategy set to Coarse for Rectangular Pocket feature in Parameters dialog box**

3. Click *OK* to apply the changes and close the dialog box.
4. Right click *Rectangular Pocket1* in the Feature tree and select *Generate Operation Plan* command on the context menu.

The Operation tree lists a *Rough Mill* operation for the rectangular pocket.

5. Click the *SOLIDWORKS CAM Feature Tree* tab to return to the Feature tree.
6. Right click *Rectangular Pocket1* in the tree and select *Parameters* in the context menu.
7. In the *Rectangular Pocket Parameters* dialog box, change the Strategy to *Rough-Finish*, and then click *OK*.

This *Rough-Finish* strategy is one of the default strategies that have been set up in the TechDB. This strategy has been set up to generate Rough Mill and Contour Mill operations for a Rectangular Pocket feature. You can add your own user-defined strategies and modify or delete existing Strategies within TechDB to customize the TechDB. Refer '*Technology Database Tutorial*' for details.

8. Right click *Rectangular Pocket1* in the Feature tree and select *Generate Operation Plan* command.

Since the *Generate Operation Plan* command has already been run once for this feature, when you execute the command again, SOLIDWORKS CAM displays the *Generate Operation Plan* dialog box which has the following choices:

**Update:** Select this option to generate operations for new features or for features that you deleted all previously generated operations. The operation list will not be updated for features that have previously generated operations.

**Regenerate:** If you select this option, all previously generated operations are deleted and new a new operation list is created. If you have modified any operations, these modifications will be lost.

**Cancel:** Click *Cancel* to revoke the *Generate Operation Plan* command.

9. Click *Regenerate* to delete the previous Rough Mill operation and generate a new operation list.

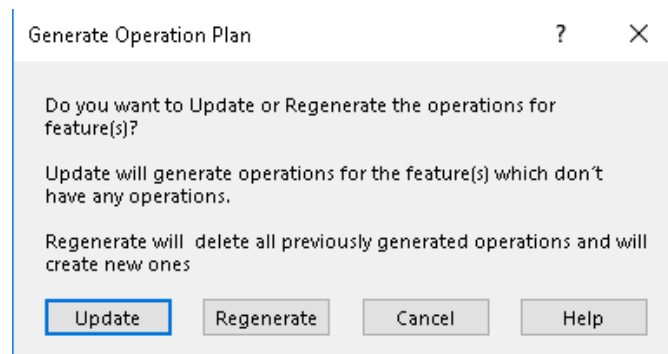

**Dialog box displayed when GOP command is executed for a feature with operation(s)**

The Operation tree lists Rough Mill and Contour Mill operations for the rectangular pocket.

10. Click the *SOLIDWORKS CAM Feature Tree* tab to return to the Feature tree.
11. Right click *Mill Part Setup1* in the Feature tree and select *Generate Operation Plan* command on the context menu.
12. Since operations already exist for at least one feature listed in the Mill Part Setup (*Rectangular Pocket1* in this case), the *Generate Operation Plan* dialog box will be displayed. Select *Update* in this dialog box in order to generate operations only for those features for which do not have operations.

You have not changed any operation parameters for the Rough Mill and Contour Mill operations that have already been generated for *Rectangular Pocket1*. Hence, you could select either *Regenerate* or *Update* because in both cases, the result would be the same. If you had modified these operations, you would want to select *Update* to generate an operation list only for the features that do not have operations.

The SOLIDWORKS CAM Operation tree now contains operations for all machinable features in the selected Mill Part Setup.

### Locating Operations for Selected Feature

You can use the *Go To* command for locating operations for the desired feature.

1. Click the *SOLIDWORKS CAM Feature Tree* tab.
2. Right click on *MS Hole1 [MSH1(inch)]* in the Feature tree and select *Go To*, then select *Operations For...* on the context menu.

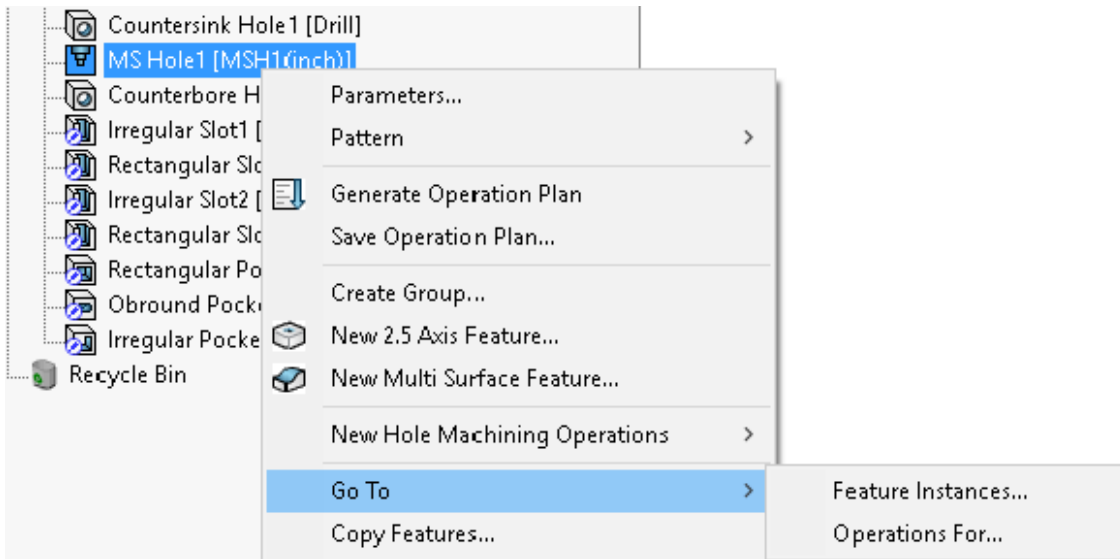

**The Operations For... command in the context menu**

This command allows you to quickly locate operations that were generated for a selected feature.

The *Find in SOLIDWORKS CAM Tree* dialog box is displayed. The operation *Center Drill3* and *Drill3* is listed in this dialog box. A lone drill operation is not enough to machine a multi-step feature.

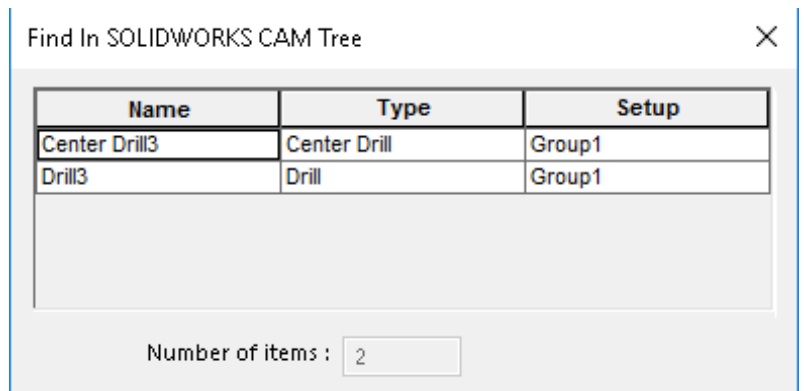

**Find in SOLIDWORKS CAM Tree dialog box**

In the TechDB, the Strategy [MSH1(inch)] has been defined to generate a center drill cycle, 2 single drill cycles, 2 Rough Mill cycles and 2 Thread Mill cycles for multi-stepped hole features. Since multi-stepped holes can be any shape, you need to define machining sequences in the TechDB that are common for machining multi-stepped holes in your facility.

---

To generate the NC code for this part, you would adjust the operation parameters as required for the operations, insert a series of operations for the multi-stepped hole, generate toolpaths, and post process the part. These steps will be explored in further tutorials.

## 2 Axis Mill 3

### Topics covered in this tutorial:

- [Defining the Stock from a Bounding Box](#)
- [Inserting Additional Mill Part Setups](#)
- [Creating a Face Feature](#)
- [Reorganizing Machinable Features](#)
- [Suppressing Machinable Features](#)
- [Inserting 2.5 Axis Features](#)
- [Combining Machinable Features](#)

In this tutorial, assume that the part starts out as a casting and machining is required only for the holes and certain faces.

In the first clamping position or Mill Part Setup, you will face the bottom of the part and drill the large center hole and the three outside holes.

In the second clamping position or Mill Part Setup, you will machine off the top center face and the three irregular corner slots (shown in dark grey color).

Note that the irregular pockets (shown in light grey color) and the part perimeter will not be machined.

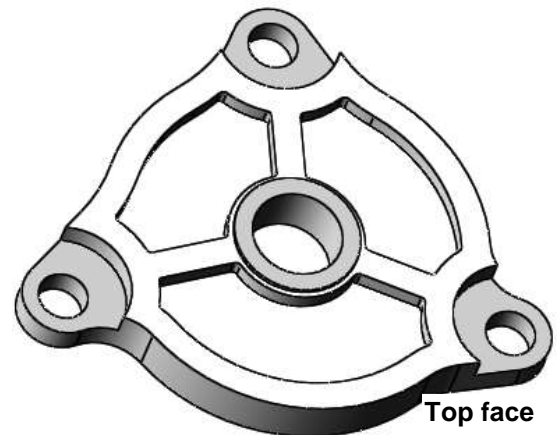
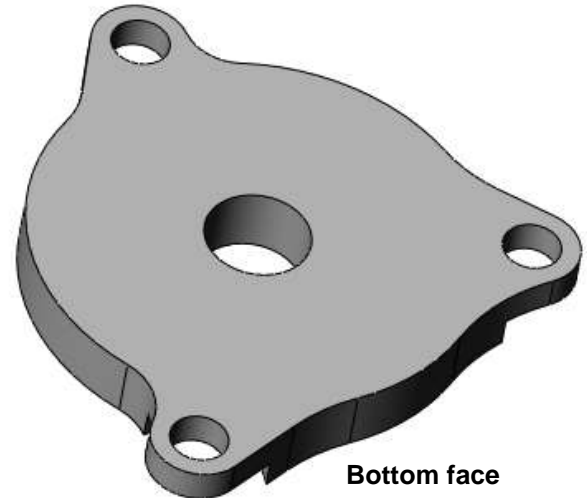

**MILL2AX\_3.SLDPRT: The part to be machined**

### Step 1: Opening the Part and Defining the Machine

1. Open part file **MILL2AX\_3.SLDPRT** in the following folder.

*C:\Users\Public\Public Documents\SOLIDWORKS\SOLIDWORKS 201x\CAM Examples\Tutorial\_Parts\Mill*

2. Click the *SOLIDWORKS CAM Feature Tree* tab.
3.  Double click on *Machine [Mill-Inch]* in the Feature tree. The Machine dialog box will be displayed.
  - On the *Machine* tab, ensure that *Mill-Inch* is the Active machine.



- Click on the *Tool Crib* tab and make sure *Tool Crib 2 (Inch)* is the Active tool set.
- Click on the *Post Processor* tab and make sure *M3AXIS-TUTORIAL* is selected; then click *OK* to close the *Machine* dialog box.

## Step 2: Defining the Stock from a Bounding Box



The stock size, shape and material type are defined next.

The stock definition serves several purposes:

- Defines the stock size and shape for simulation.
- Specifies the material type, which is used by the TechDB for feed/speed calculations.

By default, the stock shape is a cube (bounding box) whose dimensions enclose the part. However, in reality, the size of the stock is usually larger than the size of the part.

For this tutorial, assume that the part is machined from a casting that has **0.1inch** material to be removed from the top, bottom and side surfaces. You will use the default Stock Type of *Bounding box* and offset the minimum stock size by 0.1inch.

1.  Double click *Stock Manager* in the SOLIDWORKS CAM Feature tree.
2. The Stock Manager dialog box is displayed. Change the Bounding box offsets for X+, Y+, Z+, X-, Y- and Z- to a uniform **0.1in**.
3.  Click *OK* to apply the offsets and close the dialog box.

## Executing Extract Machinable Features Command

 Click the *Extract Machinable Features* button on the SOLIDWORKS CAM Command Manager.

SOLIDWORKS CAM creates the Mill Part Setup necessary to machine all of the machinable features that are recognized.

Observe that the Face features weren't recognized as this feature type was not selected in the types of features to be recognized using AFR in the [Options dialog box](#).

In this tutorial, the face feature for the top and bottom face of the part will be inserted interactively.

## Step 3: Interactive Feature Recognition

### ***Need for Interactive Feature Recognition***

SOLIDWORKS CAM may not be able to find all features on a part. On complex parts, AFR may not recognize all possible features that you want to machine or AFR may recognize a feature that might not be suitable for the intended machining process. When this occurs, you can define these features interactively.

## Deleting a Feature

For learning purposes, in this tutorial, you will have to delete the three irregular corner slot features and then insert them interactively.

1. Hold down the *Shift* key on the keyboard and click each *Irregular Slot* in the tree to highlight the items, then select *Delete* on the context menu.
2. Click *Yes* to confirm the deletion.

The features are moved to the Recycle Bin . When a feature is deleted, it is automatically placed in the Recycle Bin, which is used to store machinable features that you do not intend to machine.

3. Click the minus sign to the left of the Recycle Bin to collapse it.

## Inserting Additional Mill Part Setups

Click *Mill Part Setup1* in the Feature tree and notice that the machining direction indicated by the triad that displays in the graphics area.

*Mill Part Setup1* defines the tool direction pointing down from the top of the part. In this tutorial, you need to face the underside of the part first.

To machine the underside, you need to define a Mill Part Setup for that tool direction. New *Mill Part Setups* can be interactively inserted into the SOLIDWORKS CAM Feature tree by selecting a part face that is normal to the tool axis of the Mill Part Setup.

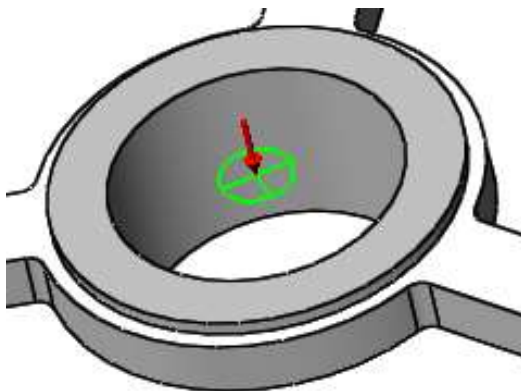

**Machining direction indicated by triad**

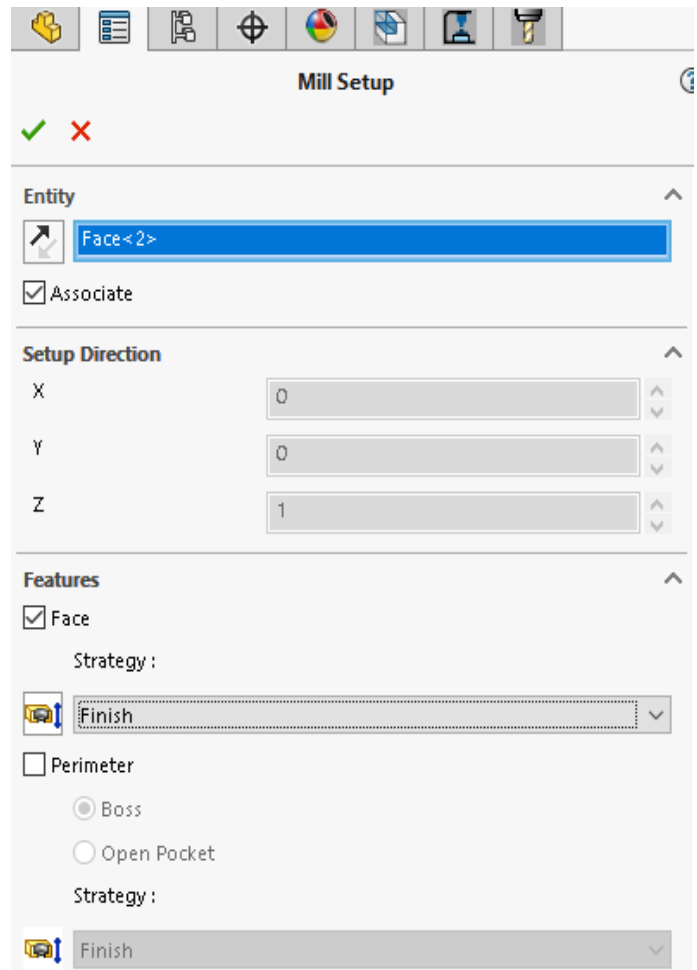

**Mill Setup Dialog box**

### Steps to interactively insert a Mill Part Setup:

1. Rotate the part so that the underside surface is visible.
2. Right click *Mill Part Setup1* in the SOLIDWORKS CAM Feature tree and select *Mill Part Setup* from the context menu. The Mill Setup dialog box is displayed.
3. In the graphics area, pick the underside face.  
This face will be listed in the *Selected Entity* field.

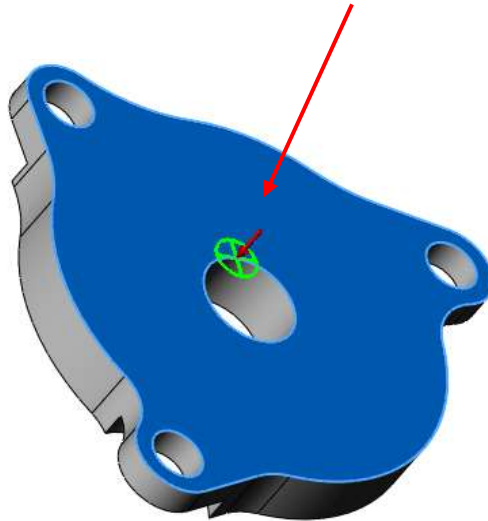

**Underside of the part**

4. In the *New Features* group box, make sure the *Face* option is checked.  
If this option is checked, when SOLIDWORKS CAM creates a Mill Part Setup, a face feature is created automatically if the top most face is parallel to the Setup and the Setup is parallel to one of the sides of the stock.
5. Set the Strategy to *Finish*.
6.  Click *OK* to close the *Mill Setup* dialog box.  
*Mill Part Setup2* is created in SOLIDWORKS CAM Feature tree with the tool direction. The Face Feature is created automatically and listed under this Mill Part Setup.  
The names for *Mill Part Setup1* and *Mill Part Setup2* can be changed to Top and Bottom or some other recognized convention.
7. Right click *Mill Part Setup1* and select *Rename* from the context menu.
8. Change the name to **Top Part Setup**, and then press *Enter*.  
Notice that when you click a Mill Part Setup in the tree, an axis displays on the part to indicate the tool direction.
9. Right click *Mill Part Setup2* and select *Rename* from the context menu.
10. Change the name to **Bottom Part Setup**, and then press *Enter*.

## Reorganizing Machinable Features

In addition to the face feature, you can also drill the hole features from the *Bottom Part Setup*. However, the hole features were recognized in the *Top Part Setup*. With the mouse, you can drag the features in the SOLIDWORKS CAM Feature tree from the *Top Part Setup* to the *Bottom Part Setup*.

1. Hold down the left mouse button and drag *Hole1* over *Bottom Part Setup*, then release the button.
  - Notice that as you drag the item, an arrow displays to indicate where the item will be positioned.
  - *Hole1* will be listed after *Bottom Part Setup*.
2. Next, hold down the left mouse button and drag *Hole Group1* over *Hole1*, then release the button.

*Hole Group1* will be listed after *Hole1*.

## Suppressing Machinable Features

You will now define features to machine the top of the part. The only machinable features left in the *Top Part Setup* are the *Open Pocket* and the three irregular pockets. Since the irregular pocket features will not be machined in this tutorial, you can either delete or suppress them. The steps below show you how to suppress these features.

1. Hold down the *Ctrl* key and select *Irregular Pocket1*, *Irregular Pocket2*, and *Irregular Pocket3* in the SOLIDWORKS CAM Feature tree.

Make sure you select all 3 features.
2. Right click and select *Suppress* from the context menu.

The icons for the features display in gray instead of magenta to indicate these features are suppressed.
3. Click *Save As* on the *File* menu.
4. The *Save as* dialog box is displayed. In the *File name* field, type an appropriate file name and click the *Save* button.

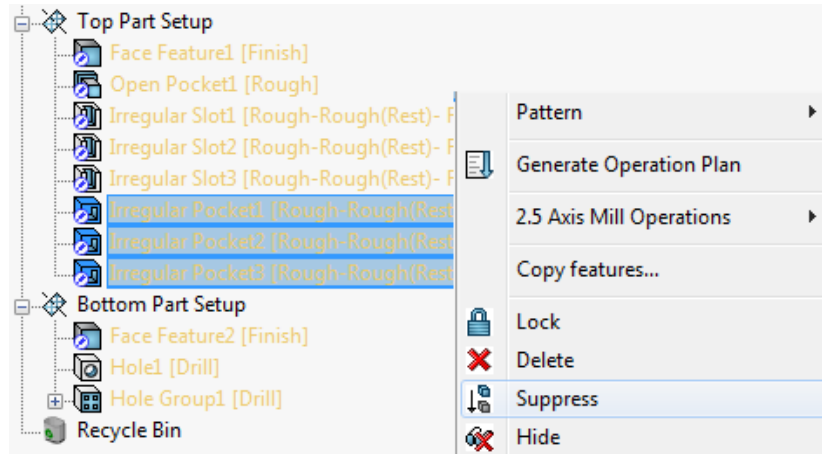

### Suppressing Features

### Inserting 2.5 Axis Features

As stated earlier, in this tutorial, the face feature and irregular slot features for this part will be inserted interactively. The face feature for the underside of the part was inserted along with the [interactive insertion of Mill Part Setup \(Bottom Part Setup\)](#).

The top of the circular boss and the three irregular slots will be machined using the *New 2.5 Axis Feature* command to define them.

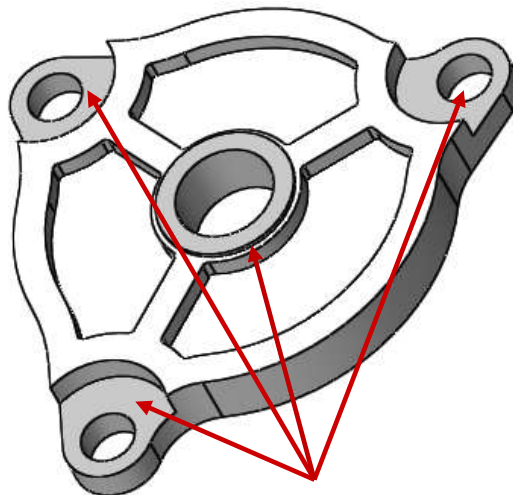

Features to be interactively inserted

#### Steps to interactively insert Face Feature:



1. Rotate the part so the top face is visible.

2. Right click *Top Part Setup* in the SOLIDWORKS CAM Feature tree and select *2.5 Axis Feature* in the context menu.
3. The *2.5 Axis Feature: Select Entities* dialog box is displayed. Click the down arrow to display the *Feature Type* list and select *Face Feature*.
4. Pick the top center face from the top of the boss. On executing this action, it is highlighted in the graphics area.



**Picking the face to interactively insert face feature**

*CW Face-3* is displayed in the *Selected Entities* field.

5.  Click the *End Conditions* button.
6. The *2.5 Axis Feature: End Conditions* dialog box will be displayed. Set the Strategy to *Finish*.
7. Leave the *End Condition Type* as *Upto Stock*.
8.  Click *OK* to insert the feature and close the dialog box.

Observe that *Face Feature3* is added at the bottom of the list of features under *Top Part Setup*.

### Steps to interactively insert Corner Slot Feature:

After insertion of the Face feature, you will now use the *2.5 Axis*

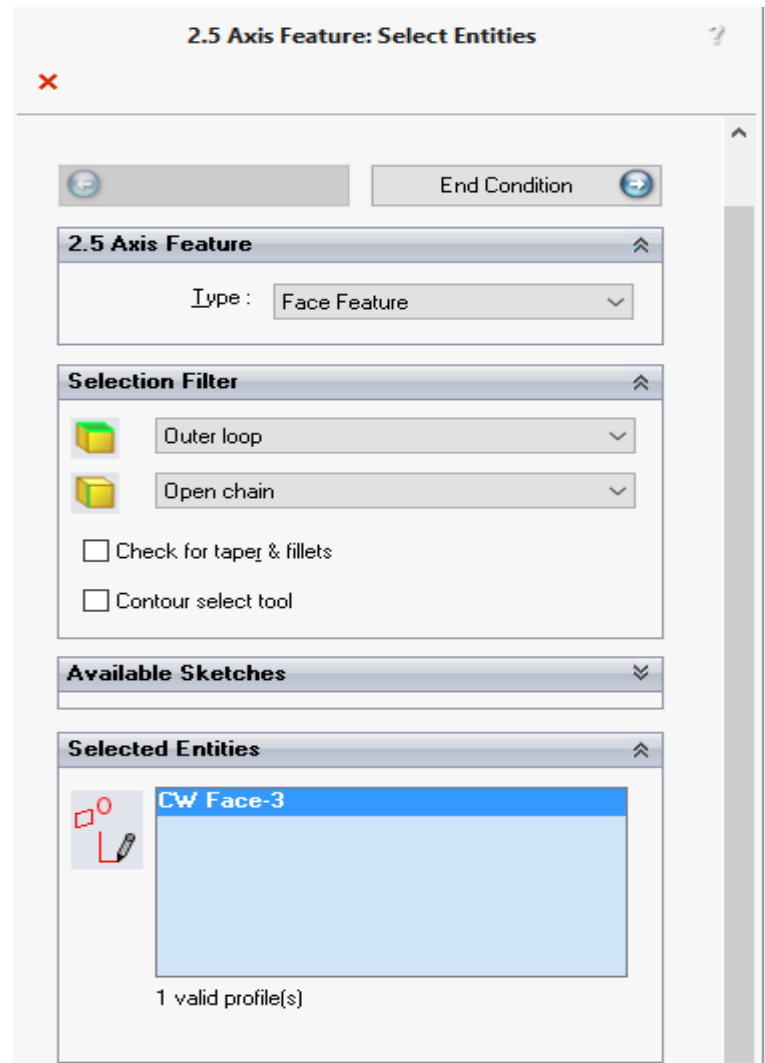

**Interactively inserting the face feature**

*Feature: Selected Entities* dialog box to define 2.5 Axis features for the three irregular corner slots.

1. Right-click on *Face Feature2* and select *2.5 Axis Feature* on the context menu.
2. In the *2.5 Axis Feature: Selected Entities* dialog box, click the down arrow to display the *Feature Type list* and select *Corner Slot*.

These slots are defined as Corner Slots because more than one edge is open. By defining it as a corner slot, the tool will machine outside the slots on the open air edges.

3. In the graphics area, pick each of the three dark grey faces of the corner slots.

The *Entities selected* list displays *CW Face-0*, *CW Face-1* and *CW Face-2*.

4.  Click the *End Conditions* button. The *2.5 Axis Feature: End Conditions* dialog box will be displayed.

The depth of material to leave for this feature will be from the face of the corner slot to the face immediately above the corner slot. You can either pick an end condition from the *End Condition* dropdown list or select a face or vertex and have SOLIDWORKS CAM set the depth automatically.

5. Leave the *End condition* set to *Blind* and pick the dark grey colored face above the corner slot.

On executing this action, the *End condition* is automatically set to *Upto Face* and the *Depth* parameter displays the distance as **0.14in.**

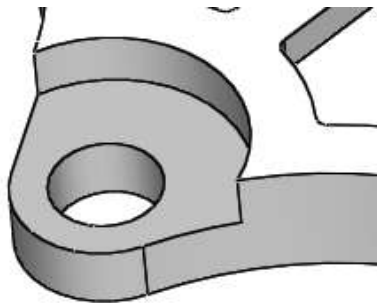

**Pick the dark grey colored face**

6. Click on the *Edit feature profiles* button.

The *2.5 Axis Feature: Feature Profiles* dialog box will be displayed. When a Corner Slot is defined from a part face, SOLIDWORKS CAM determines the open air edges automatically. If necessary, you can change the open air

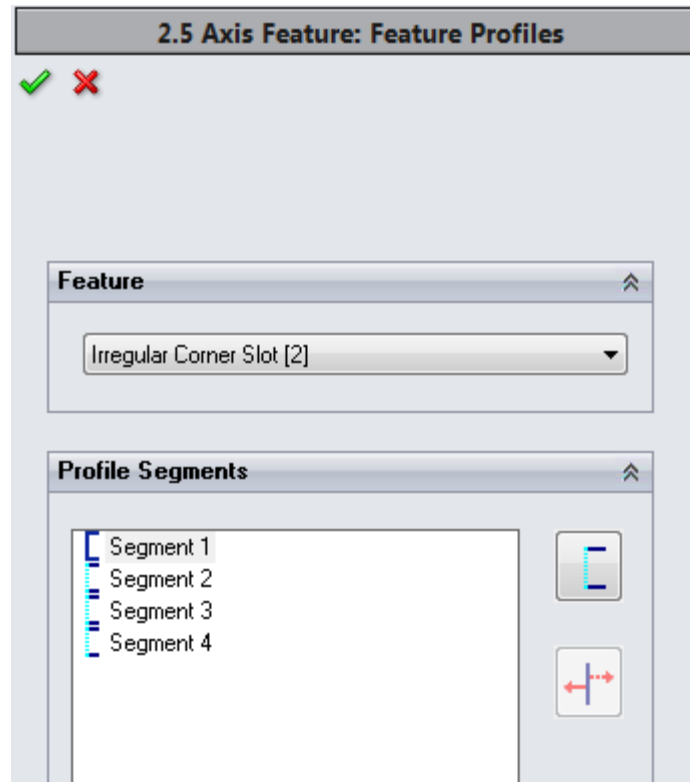

**2.5 Axis Feature: Feature Profiles dialog box**



edges.

7. Select the *Feature* for which you wish to review the open air edges in the *Feature* dropdown list. Suppose *Irregular Corner Slot (2)* is selected.

8. Select any segment in the *Profile Segments* list.

The corresponding edge is highlighted on *Irregular Corner Slot(2)*. If SOLIDWORKS CAM determined that the edge as an open air edge, then the Air Segment button is active.

9. For every segment listed in the *Profile segments* list, observe that the edges have been correctly identified by SOLIDWORKS CAM as Air Segment open/closed. You do not need to change the feature profile of any segments.

10. Click *OK*.

The *2.5 Axis Feature: End Conditions* dialog box will be displayed. This dialog box is displayed when you define a Pocket, Slot, Corner Slot, or Face Feature.

11. Click the *Island* button.

The *2.5 Axis Feature: Island Entities* dialog box will be displayed.

12. Make sure the *Detect for all* check box option is checked.

When you define multiple features and select this option, SOLIDWORKS CAM attempts to find islands for all features. If this option is not checked, SOLIDWORKS CAM attempts to find islands only for the current feature.

13. Click *Auto detect*.

SOLIDWORKS CAM does not find any islands for the corner slots.

When necessary, you could click the *Add* button and interactively insert islands.

14. Click *OK* to insert the corner slot features and close the dialog box.

The Irregular Corner Slot features are listed in the Feature tree.

All machinable features are now defined.

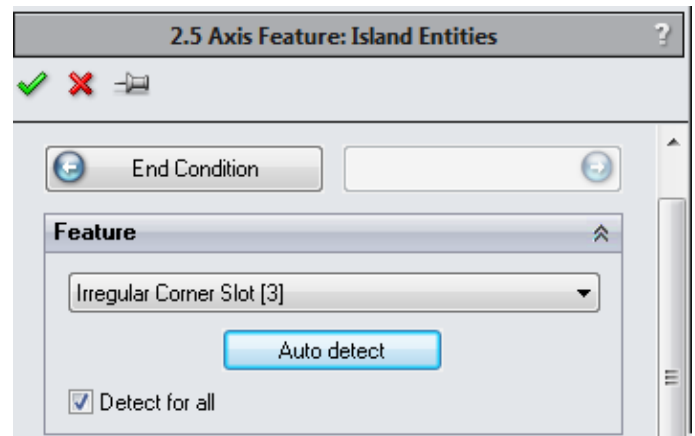

**2.5 Axis Feature: Island Entities dialog box**

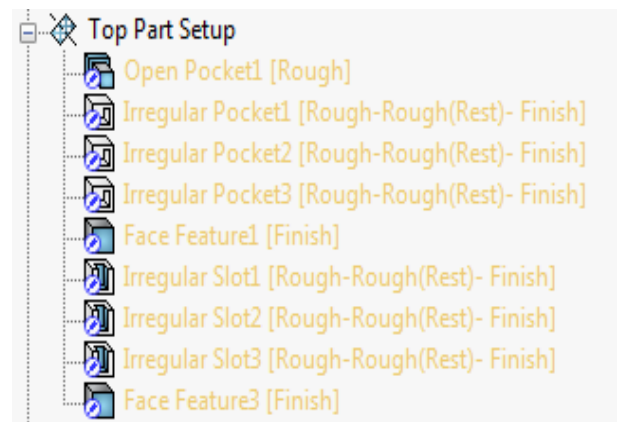

**Interactively inserted irregular slot features**

## Combining Machinable Features

### Group Features

Three Irregular Corner Slots were defined at the corners of the part. If you were to generate an operation plan now, separate operations would be created for each feature. For example, if the Technology Database defines that an Irregular Corner Slot feature will be machined with a rough and finish cycle, the *Generate Operation Plan* command would create three Rough Mill operations and three Contour Mill operations for these features.

To make it easier to manage the operation parameters for these features, you can make a single Group feature that contains all three features. As a Group feature, the three Irregular Corner Slot features will be machined with one set of operations.

### Steps to create a Group Feature:

In this tutorial, the irregular corner slot features will be grouped. Following are the steps to group the features:

1. Right click the first Irregular Corner Slot (*Irregular Corner Slot1*) in the

SOLIDWORKS CAM Feature tree and select *Create Group* in the RMB context menu.

The *Edit Feature Group* dialog box will be displayed.

The *Feature List* on the right displays the selected feature. The *Available Features* list on the left shows other features of the same type and depth that can be added to make the Group feature.

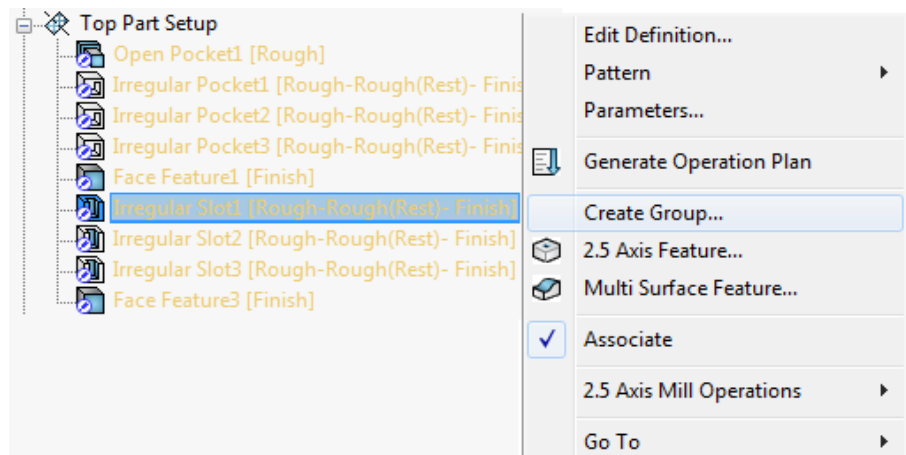

Create Group command on the RMB context menu

2. Pick *Irregular Corner Slot2*, click *Add*.
3. Observe that this feature is added to the *Feature List* on the right. Pick *Irregular Corner Slot3* and click *Add*.
4. Click *OK* to create the group and close the dialog box.

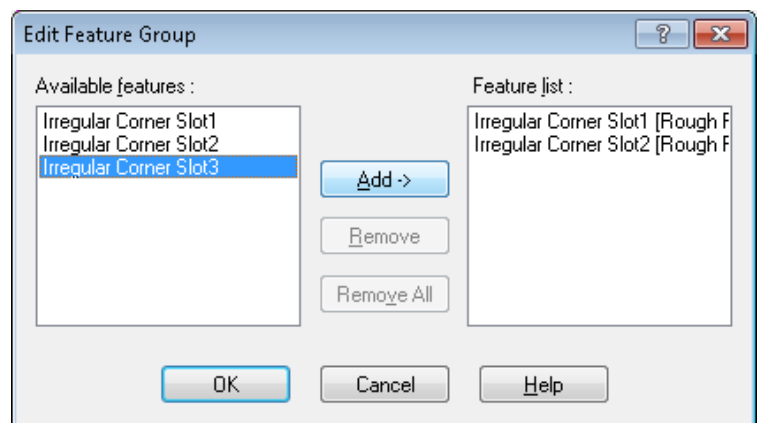

Edit feature Group Dialog Box

The three pockets are combined into a single feature labeled *Irregular Slot Group2* in the SOLIDWORKS CAM Feature tree.

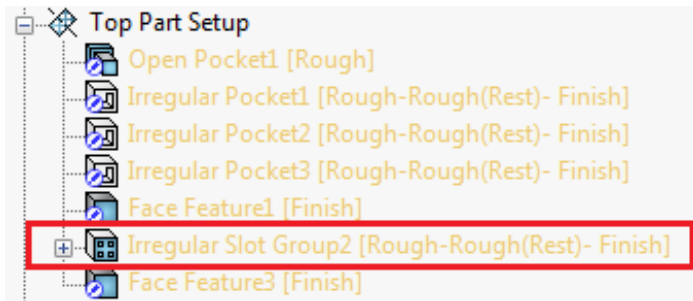

**Group Feature added**

## Step 5: Generate Operation Plan and Toolpaths

### ***Generate an Operation Plan for each Mill Part Setup***

1.  Click the *Generate Operation Plan* button on the SOLIDWORKS CAM Command Manager.

OR

Right click *SOLIDWORKS CAM NC Manager* in the SOLIDWORKS CAM Feature tree, select *Generate Operation Plan* from the context menu.

Operations are created for the machinable features in the *Bottom Part Setup* and *Top Part Setup*.

The operations are listed in the Operation tree in the same order as their associated machinable features. You can easily change the order.

2. Observe that *Center Drill* operations and *Drill2* operations under *Bottom Part Setup* have a red exclamation mark because the tool assigned to these operations are not from the active tool crib.  
Right-click on each of these operations and select *What's Wrong?* from the context menu. In the Errors message box that is displayed, click the Clear button in order to get rid of the exclamation mark.
3. If the Face Mill operation is not listed first in the *Top Part Setup* or *Bottom Part Setup*, you can drag and drop this operation to the first position.
4. In the *Top Part Setup*, press and hold down the left mouse button with the pointer over *Face Mill*.
5. Drag the operation over the top of *Top Part Setup* and release the button.  
The Operation tree re-displays with the operation moved to the new location.

6. Repeat steps 2 for *Face Mill2* of *Bottom Part Setup* and drag the operation over the top of *Bottom Part Setup* and release the button. This action moves it first position under the *Bottom Part Setup*.

## **Generate Toolpaths and Post Process the Part**

### **Verify Operation Parameters and Generating Toolpath**

1. Double click each operation item in the tree to open the Operation Parameters dialog box and review the cutting parameters.
2. After you have verified that the parameters for each operation are set the way you want them, right click *Bottom Part Setup* in the SOLIDWORKS CAM Operation tree and select *Generate Toolpath* command in the RMB context menu.
3. Repeat step 2 for the *Top Part Setup*.
4. Experiment by changing parameters for the operations and regenerating the toolpaths.

## **SOLIDWORKS CAM Message Window**

Check the SOLIDWORKS CAM Message Window.

- The Message Window provides information you may find helpful. For example, based on the information in this window, you may want to change a tool or insert a finish operation in order to cut a machinable feature completely.
  - If the Message Window is not displayed, select  SOLIDWORKS CAM *Options* on the SOLIDWORKS CAM Command Manager and check the Message Window check box on the General tab.
- You can move the window and adjust the size. To change the size, point to a border or corner of the window (the pointer changes to a two-headed arrow). Drag the corner or border until the window is the size you want, and then release the mouse button.

## **Simulating the Toolpath**



SOLIDWORKS CAM provides the ability to simulate toolpaths showing the tool movement and the resulting shape of the part.

1. Click the *Simulate Toolpath* button on the SOLIDWORKS CAM Command Manager.
2.  Click the *Run* button.

Observe the simulated toolpath. In case of any errors or collisions, modify the Operation Parameters, regenerate toolpaths and simulate the toolpaths once again. Observe that the perimeter of the part is not simulated since no part perimeter feature was inserted in the list of features to be machined.
3.  Click the *Close* button in the upper right corner of the *Simulation* toolbar to exit Simulation mode.

---

## Step 6: Post Processing the Toolpaths

1. Right click *Bottom Part Setup* in the SOLIDWORKS CAM Operation tree and select *Post Process* in the RMB context menu.
2. In the *Save Post Output File* dialog box, click *Save* to accept the default file name. Change the file name if required.  
Note that if you are running SOLIDWORKS CAM in Demonstration mode, this menu option and dialog box does not display.
3. The *Post Process Output* dialog box is displayed. In the *Display* group box of this dialog box, check the *Centerline* option so that the toolpath will be highlighted as each line of code is produced.
4. Click the *Play* button .  
NC code is created for the *Bottom Part Setup*.
5. After viewing the code, click *OK* to close the dialog box.
6. Right click *Top Part Setup* in the SOLIDWORKS CAM Operation tree and select *Post Process* in the RMB context menu.
7. In the *Save Post File* dialog box, type a suitable file name.
8. In the *Post Process Output* dialog box, click the *Play* button  NC code will be created for the *Top Part Setup*.
9. Click *OK* to close the dialog box.
10. Open the saved Post process files. Observe that the generated NC code has been saved.

## 2 Axis Mill 4

### Topics covered in this tutorial:

- [Defining the Stock from a Sketch](#)
- [Inserting Open Pocket Feature](#)
- [Adjusting Operation Parameters](#)
- [Deleting an Operation](#)
- [Inserting an Operation](#)
- [Defining Program Zero](#)
- [Sorting Operations](#)

This tutorial guides you through the steps to machine the part shown below. The concepts given above (under What You'll Learn) will be explained during the execution of the steps required to machine this part.

You are expected to have an understanding of the concepts explained in the previous three tutorials before beginning with this tutorial.

### Sequence of machining:

#### Mill Part Setup1: To machine the top side of the part

- Drill two holes on each end of part.
- Face top of part.
- Face depression on left side of part.
- Finish profiles the hole on each end of the part.
- Rough and finish rectangular pocket.
- Finish machine three obround holes.
- Rough and finish outside part shape from stock (open pocket).

#### Mill Part Setup2: To machine the bottom side of the part

- Face the bottom of the part.
- Rough and finish the two depressions on the bottom of the part.

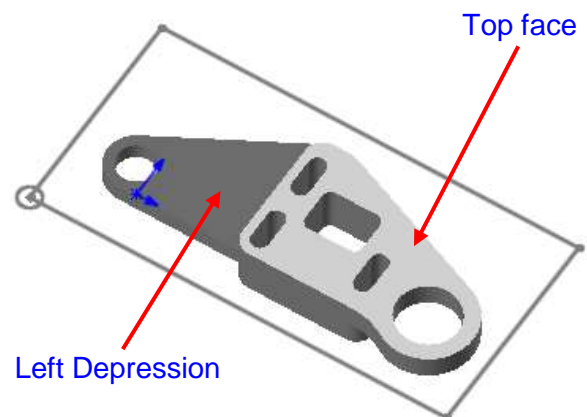

Upper side of the part to be machined

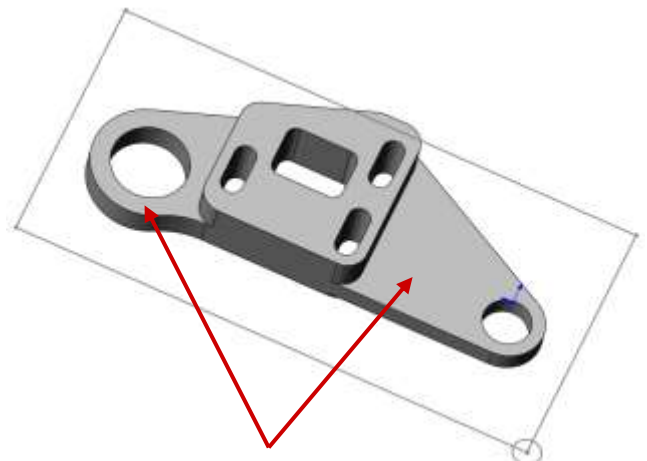

Bottom Face depressions (irregular slots)



## Step 1: Opening the Part and Defining the Machine

1. Open the part file **MILL2AX\_4.SLDPRT** in the following folder.  
*C:\Users\Public\Documents\SOLIDWORKS\SOLIDWORKS 201x\CAM Examples\Tutorial\_Parts\Mill*
2. Click the *SOLIDWORKS CAM Feature Tree* tab.
3. Double click *Machine [Mill-Inch]* in the Feature tree. The *Machine* dialog box will be displayed.
  - On the Machine tab, *Mill-Inch* is the Active machine.
  - Click the *Tool Crib* tab and make sure *Tool Crib 2 (Inch)* is the active tool crib.
  - Click the *Post Processor* tab and make sure *M3AXIS-TUTORIAL* is selected.
  - Click *OK* to apply these settings and close the *Machine* dialog box.

## Step 2: Defining the Stock from a Sketch

For this part, consider that the stock is a block of material that does not have the same amount of material on all sides. For such cases, SOLIDWORKS CAM has the provision to define a stock using a pre-defined sketch and user-input depth.

In this tutorial, you will define it using a rectangular sketch and a depth. A sketch named *Stock Profile* has already been created in this part. The sketch plane is positioned **0.05in** above the top of the part.

1. Double click *Stock Manager* in the SOLIDWORKS CAM Feature tree to open the *Stock Manager* dialog box.  
 SOLIDWORKS CAM automatically calculates the stock size and shape based on the smallest block possible. You can change this definition by specifying a sketch and depth.
2. Under *Stock Type*, select *Extruded Sketch*.
3. Pick the rectangular sketch in the graphics area.  
 The sketch will be highlighted.
4. Set the Depth to **1in**.

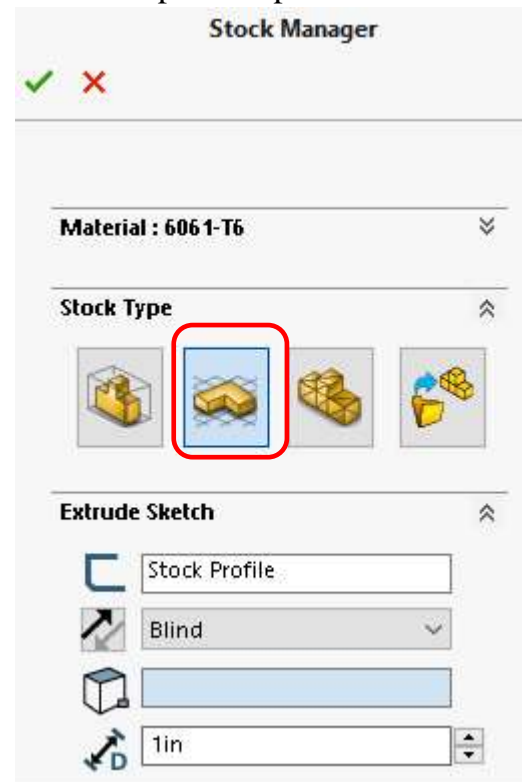



**Stock Manager Dialog Box**

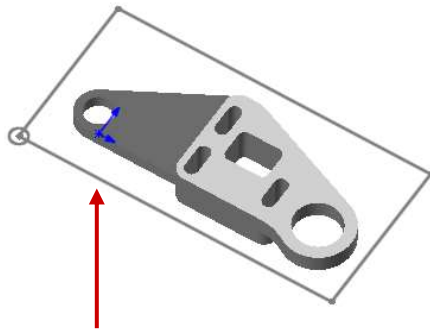



Select Sketch

5.  If the stock doesn't extrude in the correct direction, click the *Reverse Direction* button.
6.  Click *OK* to apply the changes and close the dialog box.
7. Left click on the *Stock Manager* in the Feature tree to see an outline of the stock.

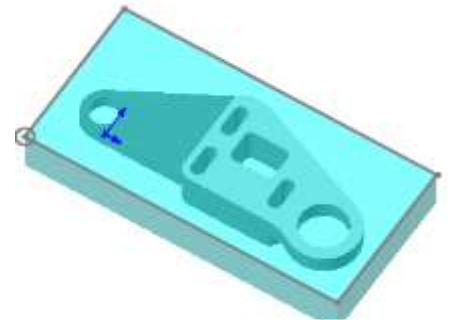

Stock extruded in correct direction

### Step 3: Extracting Machinable Features

#### **Settings for Recognizing Face Feature Automatically**

1.  Click the SOLIDWORKS CAM *Options* button on the SOLIDWORKS CAM Command Manager. The *Options* dialog box will be displayed.
2. Click the *Mill Features* tab in the *Options* dialog box.
3. Under *Feature Types*, check the *Face* option.
4. Click *OK* to apply the changes and close the dialog box.

#### **Automatic Feature Recognition**

1.  Click the *Extract Machinable Features* button on the SOLIDWORKS CAM Command Manager.

SOLIDWORKS CAM creates the Mill Part Setups necessary to machine all of the machinable features that are recognized.

Under *Mill Part Setup1*, the recognized features include the face feature, two holes, the rectangular pocket and the three obround pockets, which are included in *Obround Pocket Group1*.

*Mill Part Setup2* machines features from the bottom. Under *Mill Part Setup2*, the recognized features include the face feature and the two depressions which are recognized as Irregular slot features.

2. Click *Mill Part Setup1* in the Feature tree and check the machining direction that displays on the part.

All the hole and pocket features go through the part. Hence, AFR may determine the machining direction either from the top or the bottom of the part. If these features are recognized from the bottom direction instead of from the top as shown in the image of the previous page, drag and drop these features from *Mill Part Setup2* to *Mill Part Setup1*.

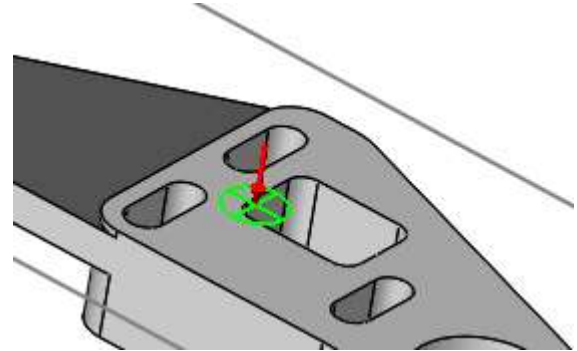

**Correct direction for machining Hole & Pockets features**

#### Step 4: Interactively Inserting Features

For this tutorial, you will interactively define an Open Pocket (feature that defines the outside profile of the part so it can be machined from the stock). This feature is created from a sketch.



#### **Steps to Interactively insert an Open Pocket Feature**

##### **Need for Open Pocket Feature**

For this tutorial, you will rough the part from the stock, then finish machine the perimeter of the part. In order to do this, you define the stock perimeter as an Open Pocket and the part as an island in this pocket. The interactively inserted 2.5 Axis Open Pocket feature will be used to machine the perimeter of the part.

By defining this 2.5 Axis feature as an Open Pocket, the toolpath will extend beyond the stock perimeter so that all of the material will be removed. In comparison, if the stock perimeter were defined as a simple Pocket, the roughing toolpath would be constrained within the perimeter of the stock leaving unmachined areas in the corners.

## Steps to interactively insert Open Pocket Feature:

1. In the Feature Tree, right click *Mill Part Setup1* and select *2.5 Axis Feature* command on the context menu.
2. The *2.5 Axis Feature: Select Entities* dialog box will be displayed. In this dialog box, select *Open Pocket* for the Feature Type.
3. In the *Available sketches* list, select the sketch labeled *Stock Profile*.
4.  Click *End Condition* button.
5. The *2.5 Axis Feature: End Conditions* dialog box will be displayed. In the 2.5 Axis feature group box:
  - i. Set the *Strategy* set to *Rough-Finish*.
  - ii. Check the *Through* checkbox option.  
With this option checked, the feature will be machined slightly deeper than the stock to remove all material.
6. In the *End condition – Direction 1* group box, click on the dropdown list and set the End condition to *Upto Stock*.
7. In the *Feature Profile* group box, leave the *Use Stock Extents* option checked.
8.  Click *Island* button at the top of the dialog box.

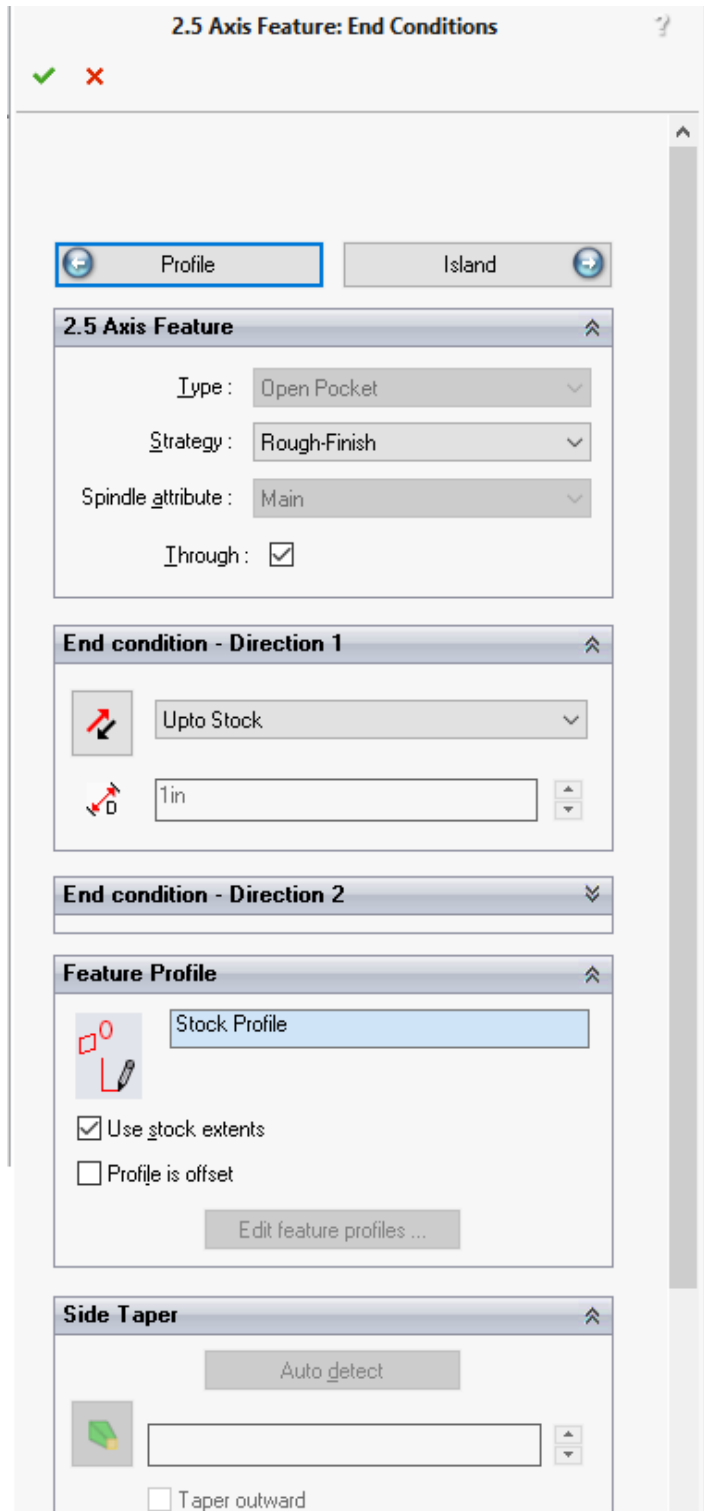

**2.5 Axis Feature: End Conditions dialog box**

9. The *2.5 Axis Feature: Island Entities* dialog box will be displayed. Click the *Auto detect* button.

SOLIDWORKS CAM considers a flat face that is normal to the Mill Part Setup as an island. In this part, the top face of the part and the left depression face are both flat and normal to the current Mill Part Setup (*Mill Part Setup1*) and are therefore identified as islands automatically.

When necessary, you can define islands interactively by clicking the *Add* button in this dialog box and selecting faces, edges, loops and sketches.

10.  Click *OK* to insert the feature and close the dialog box.

The Open Pocket Feature (*Open Pocket1*) is now listed at the bottom of *Mill Part Setup1* in the SOLIDWORKS CAM Feature tree.

Operations are generated for features in the same sequence as the features appear in a Mill Part Setup. Rearranging these features will ensure that when operations are generated for these features by executing the *Generate Operation Plan* command, then operations are sequenced in the same order as the features.

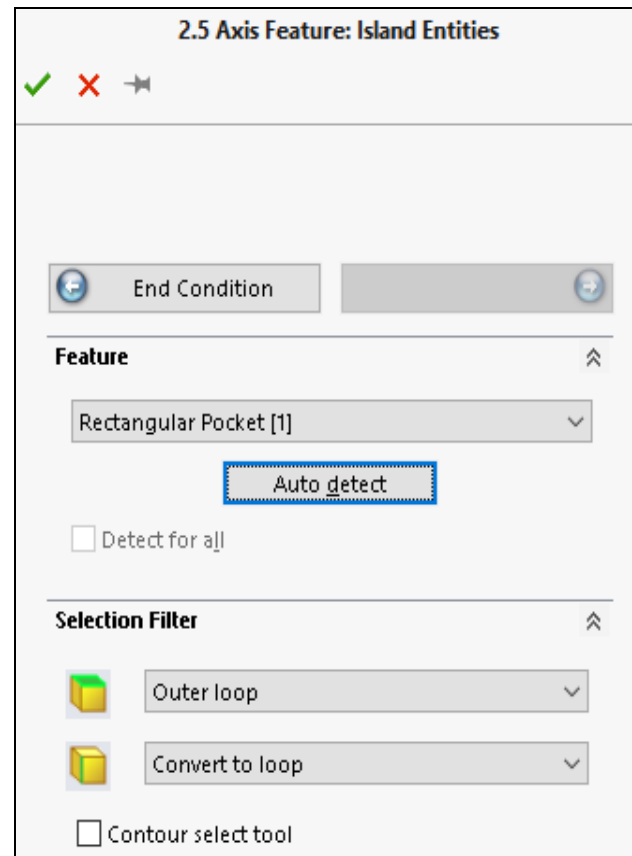

**2.5 Axis Feature: Island Entities dialog box**

## Step 5: Generating Operations

### **Changing Feature Strategy before Generating Operations**

Before the *Operation Plan* is generated, strategies can be assigned to features so as to affect the operations that are created for each feature. In this tutorial, you will change the default strategy of *Rectangular Pocket1*.

1. In the Feature tree, right click *Rectangular Pocket1* and select *Parameters* on the context menu to open the *Rectangular Pocket Parameters* dialog box.
2. In this dialog box, set the *Strategy* to *Rough*.
3. Click *OK* to apply the changes and close the dialog box.

This system *Strategy* has been set up in the TechDB to generate a Rough Mill operation for a Rectangular Pocket feature.

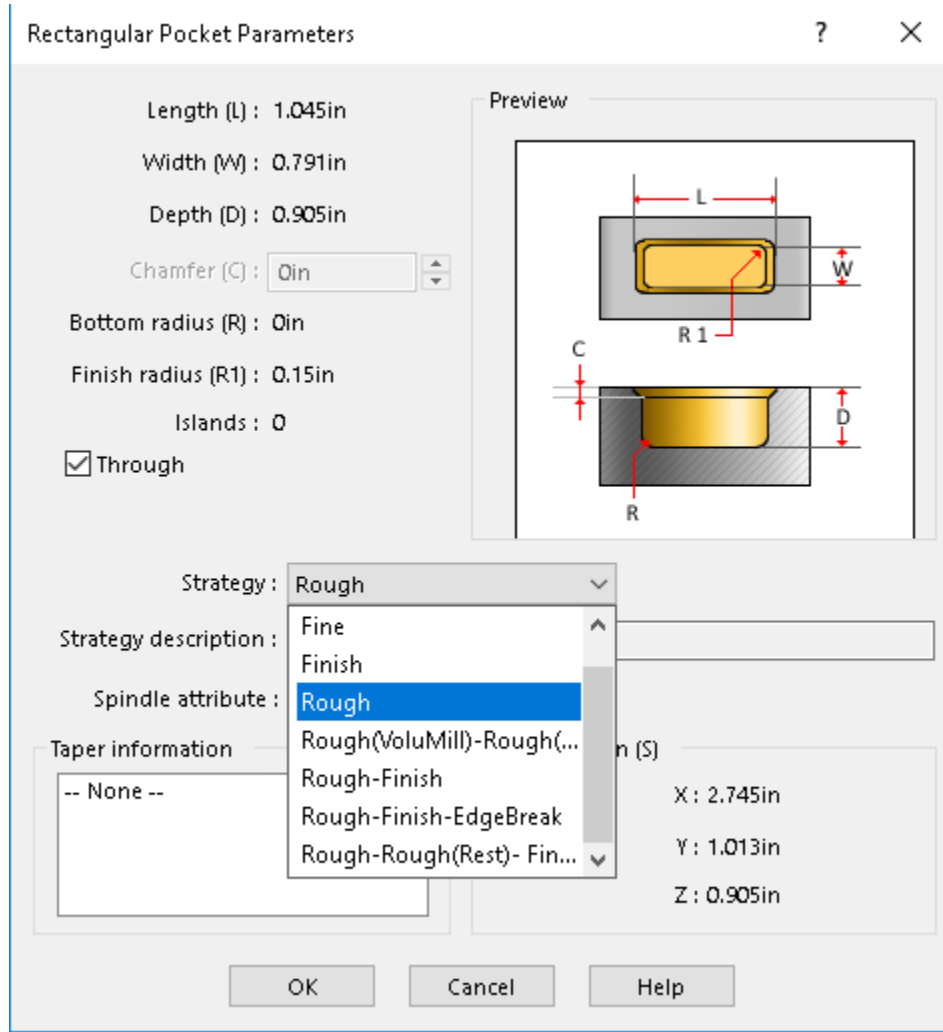

**Setting the Strategy to 'Rough' for Rectangular Pocket Feature**

### **Executing Generate Operation Plan Command**

1.  Click the *Generate Operation Plan* button on the SOLIDWORKS CAM Command Manager. The operations are listed in the Operation tree for both *Mill Part Setup1* and *Mill Part Setup2*.

OR

Right click *Mill Part Setup1* in the tree and select *Generate Operation Plan* in the context menu.

Operations will be generated for *Mill Part Setup1* in the SOLIDWORKS CAM Operation tree.

2. Switch back to the *SOLIDWORKS CAM* Feature tree.
3. Right click *Mill Part Setup2* and select *Generate Operation Plan* in the context menu.

Operations will now be generated for *Mill Part Setup2* in the SOLIDWORKS CAM Operation tree.

4. Click on the plus symbol  next to each operation under *Mill Part Setup1*. This action expands the tree to identify the feature that is machined by the particular operation.
5. Observe that the operations are generated for the features in the same sequence as the features listed in the Feature tree. This is true for both *Mill Part Setup1* and *Mill Part Setup2*.
6. A yellow exclamation mark over certain operations indicates that the tools assigned to those operations were not assigned from the active tool crib. You can right-click on such operations and select *What's wrong?* on the context menu. Click on the *Clear* button on the displayed error message to get rid of the exclamation mark.

### **Adjusting Operation Parameters**

The operations that are generated by SOLIDWORKS CAM are based on information stored in the Technology Database. Each operation contains parameters that affect how the toolpath is created and specific parameters that will be output to the NC program. These parameters can be edited before generating the toolpaths and post processing the part.

In this tutorial, you will edit the Operation Parameters of the following operations:



- For the Contour Mill Operation generated for Obround Pocket Group feature, the tool used to machine the operation will be changed.
- For the Rough Mill Operations generated for the Irregular Slot Features and Obround Pocket Group feature, the tool parameters will be changed.

### **Expanding and Collapsing Items in the Tree**

1. Click the  symbol next to *Contour Mill4* in the SOLIDWORKS CAM Operation tree.

The tree expands to identify the *Obround Pocket Group1* as the feature for which the operation was generated for.

2. To collapse this item, click on the  symbol next to *Contour Mill4*.

You can use either  and  symbols or the *Expand Items* and *Collapse Items* command on the context menus to view items in the trees.

### **Steps to change the Allowance for an Operation:**

1. In the Operation tree, double click *Contour Mill4*.

OR

Right click *Contour Mill4* and select *Edit Definition* on the context menu.

2. The *Operation Parameters* dialog box will be displayed.

3. Click the *Contour* tab of the Operation Parameters dialog box.
4. In the *Side parameters* group box, ensure the *Allowance* is set to **0in**.  
Setting the *Allowance* to this value ensures that the pockets are cut to size.
5. Click *OK* to apply the changes and close the *Operation Parameters* dialog box.

### Steps to change the tool parameters:

1. In the Operation tree, double click *Rough Mill2*.

OR

Right click *Rough Mill2* and select *Edit Definition* on the context menu.

*Rough Mill2* operation is used to rough the Irregular Slot feature on the left side of the top face of the part.

2. The *Operation Parameters* dialog box will be displayed. Click on the *Tool* tab.
3. Click on the *Mill Tool* page. It displays the parameters of the selected tool. Observe the *Tool Usage* value. This value indicates the number of operations currently using this tool.

The Rough Mill operation for Hole Feature under *Mill Part Setup1*, Rough Mill and Contour Mill operations for *Irregular Slot2* feature and Rough Mill operation for *Irregular Slot3* feature under *Mill Part Setup2* also use this tool.

4. In the *Cut Diameter (D1)* field, change the diameter to **0.745in**.
5. Click the *OK* button to apply the changes.



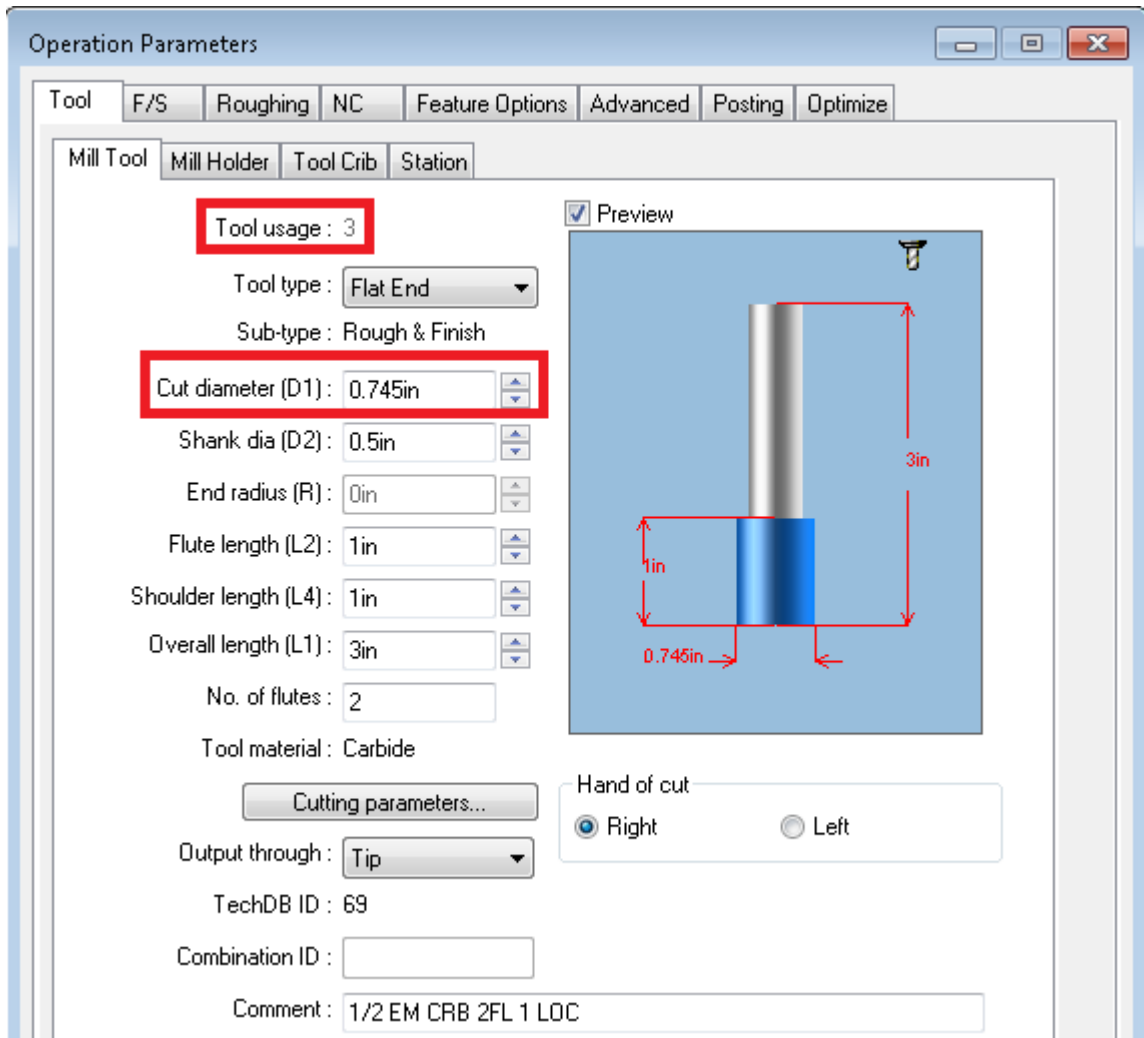

### Changing Mill Tool Parameters

- Since this tool is also shared by **two** other operations, making any changes will affect those operations too. Therefore, SOLIDWORKS CAM will display a warning message to this effect and prompt you to choose whether the changes are to be applied to the other operations or not.
- Click *Change* within the message box.

**Change:** When you click *Change* within this dialog box, then the changes made to the tool parameters will affect all other operations sharing this tool.

**Add:** If you click *Add* within the warning message dialog box, then SOLIDWORKS CAM creates a new tool with the changed tool parameters and lists this tool in the Active Tool crib. This action ensures that the changes made to the tool parameters will affect only the current operation and none of the other operations which share the same tool.

Note that irrespective of which option you choose, the changes made to the tool parameters are applicable only for machining of the current part. The changes made to the tool parameters are not saved to the Technology Database.

To save the changes made to the tool parameters in the Technology Database, you have to execute the *Save Operation Plan* command. This functionality is explained in a later tutorial.

- In the Operation tree, observe the Rough Mill operations sharing this tool. Observe that the diameter of the *Flat End* tool given within the brackets now displays the edited values for all these operations.

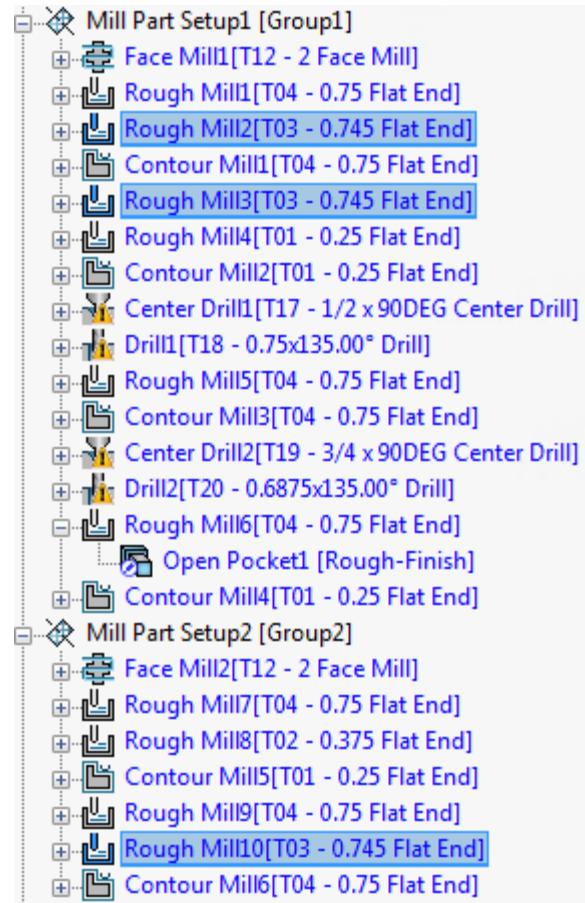

**Operations sharing the tool**

### Deleting an Operation

In some cases, it may be desirable to delete operations that are created automatically or to replace automatically created operations with interactively inserted operations. In this tutorial, two operations were automatically created for the *Obround Pocket Group1* feature - Rough Mill operation (*Rough Mill4*) and Contour Mill operation (*Contour Mill2*). The tool that is selected in the Contour Mill operation for this feature can machine the feature completely. Hence, the Rough Mill operation can be deleted.

#### Steps to delete an operation:

- In the SOLIDWORKS CAM Operation tree, right click *Rough Mill4* (the roughing operation for the *Obround Pocket Group1*) and select *Delete* on the context menu.
- SOLIDWORKS CAM will display a warning message asking whether you are sure that you want to delete the operation and all dependent items. Click *Yes* to confirm to deletion.

The operation will be removed from the Operation tree and placed in the Recycle bin .

### Inserting an Operation

The obround pocket group feature is now machined using a single Contour Mill operation. To give a better finish, you can interactively insert an additional Contour Mill

operation the makes use of a tool with smaller cut diameter which will finish machine the obround pocket features.

In this tutorial, you will interactively insert an additional Contour Mill operation for *Obround Pocket Group1*. This operation will be inserted after the *Contour Mill2* operation.

### Steps to interactively insert an operation:

1. In the Operation tree, right click *Contour Mill2* operation and select *Edit Definition* to open the *Operation Parameters* dialog box.
2. Click on the *Contour* Tab and in the *Side Parameters* group box, set the allowance to **0.05in**.
3. Click *OK* to apply the changes and close the dialog box.
4. The new Contour Mill operation is to be inserted after *Contour Mill2* operation. Right click *Contour Mill2* in the SOLIDWORKS CAM Operation tree and select *2.5 Axis Mill Operations >>Contour Mill*.

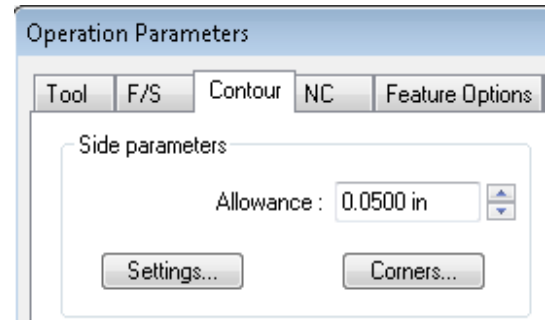

**Setting Allowance value**

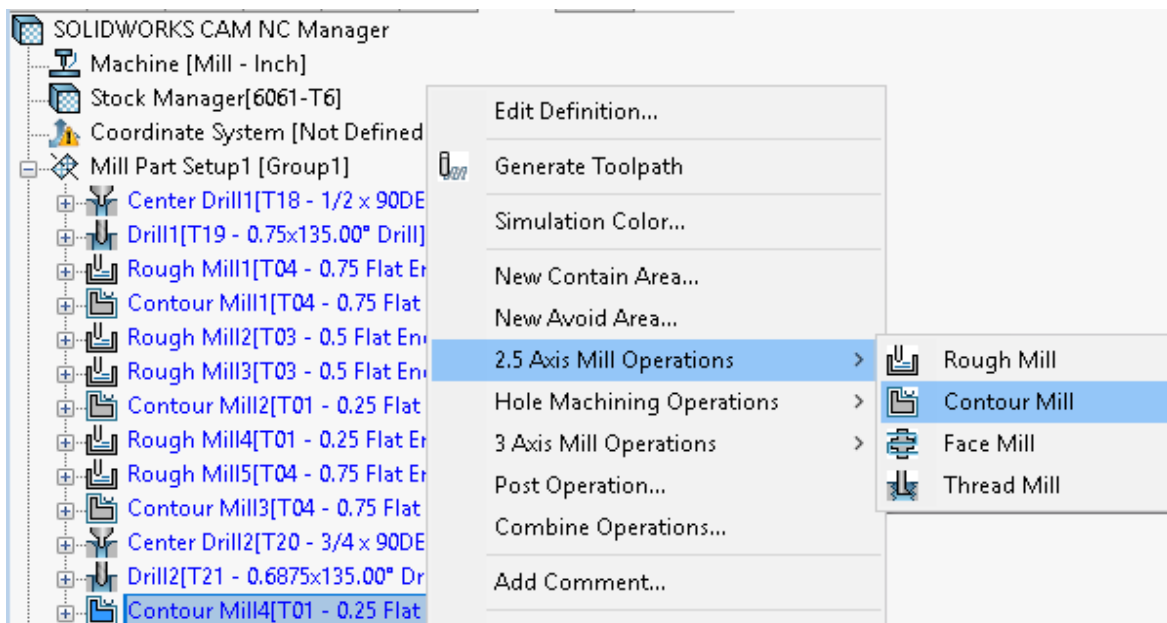

**Selecting command to New a 2.5 Axis Operation interactively**

5. The *New Operation: Contour Mill* dialog box will be displayed. Click on the *Features* tab.

6. In the *Pick from the available* list box within this tab, select *Obround Pocket Group1* by placing a check in its corresponding checkbox. This action will list the selected feature group in the *Selected Features* list box at the top of the tab.

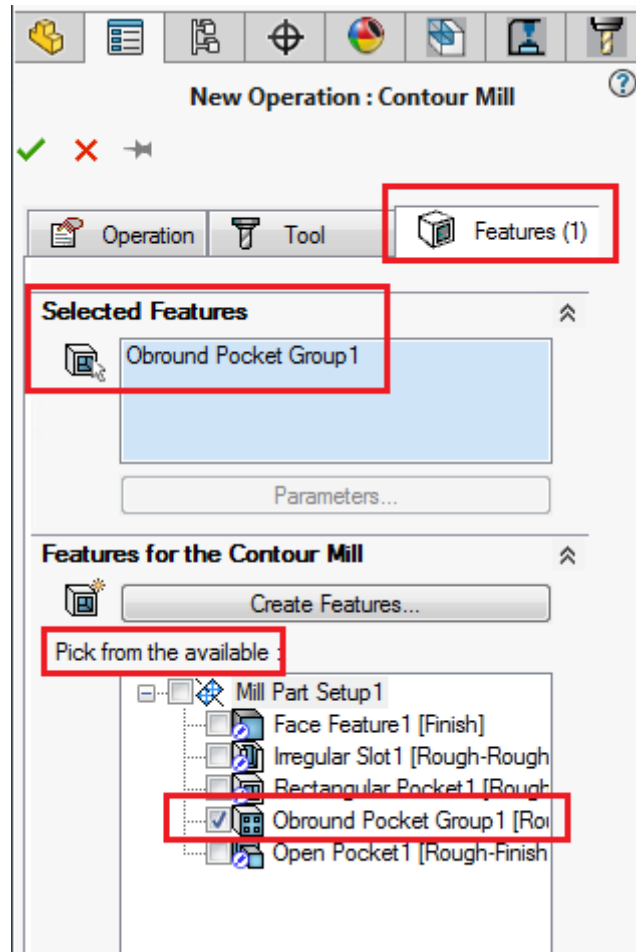

**'Features' tab of the New Operation dialog box**

7. Click on the *Tool* tab. Within this tab, observe that a **0.25in** Flat End Mill tool has been assigned to this operation. Since this operation finish machines the feature, a tool with lower diameter needs to be selected. In this tutorial, we will assign a **0.125in** tool.
- In the *Tool list* box, observe that there is no Flat End tool with **0.125in** tool diameter. So, the desired tool needs to be added from the Tool Library.
- Click on the *Add New* button.
  - The *Tool Select Filter* dialog box will be displayed.
  - For Tool Type, select *Flat End*.
  - In the *Filter by* group box, place a check in the *Diameter* checkbox. Enter the lower diameter range as **0in** and higher range as **0.25in**.

- v. From the list of displayed tools at the bottom of this dialog box, highlight a tool with **0.125in** diameter.
- vi. Click the *OK* button.
- vii. The selected tool will be listed in the *Tool list* box.

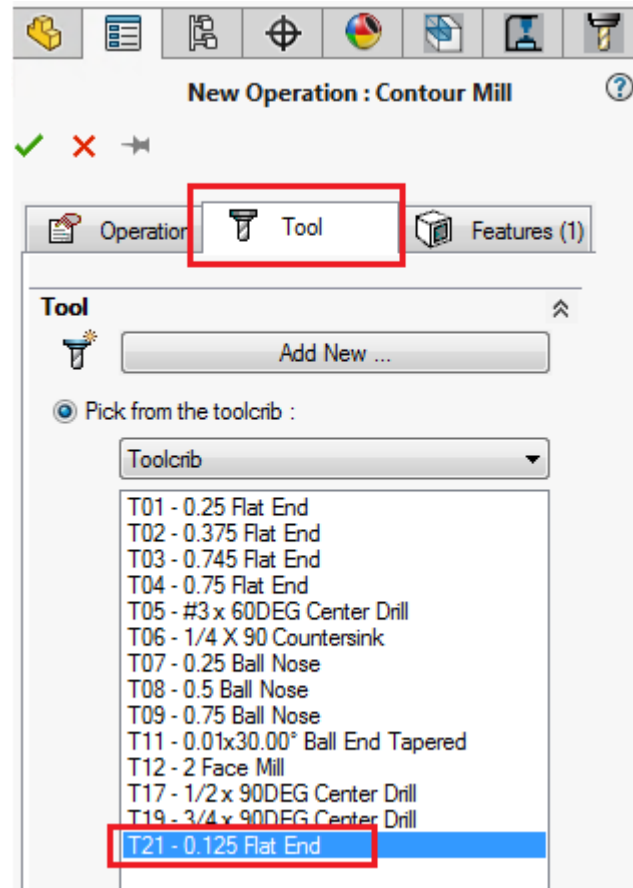

'Tool' tab of the New Operation dialog box

- Click on the *Operation* tab. In the *Options* group box at the bottom of this tab, ensure that the *Edit operation on creation* option is checked.

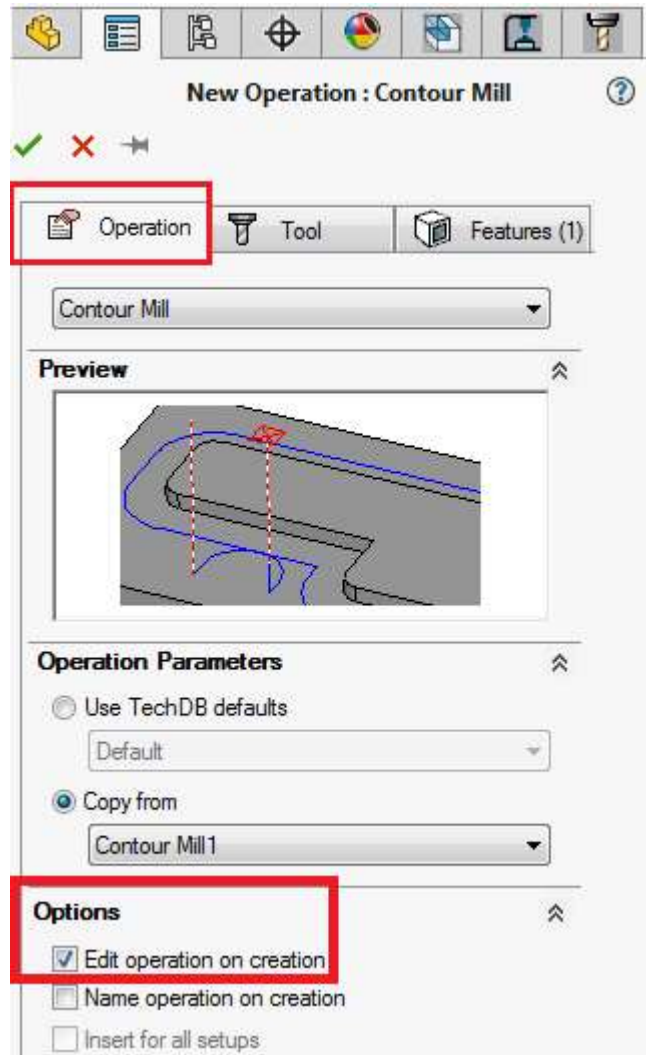

**'Operation' tab of the New Operation dialog box**

- Click the *OK* button at top left corner of the dialog box to insert the operation. The *Operation Parameters* dialog box for the newly inserted operation will be displayed.
- Click *OK* to close the *Operation Parameters* dialog box.

Under *Mill Part Setup1*, a *Contour Mill7* operation is added after *Contour Mill4*.

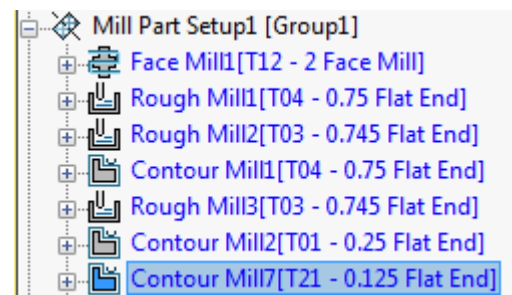

**Contour Mill Operation inserted**

## Step 6: Defining Program Zero

The Mill Part Setup defines the tool direction as well as the Program Zero. Program zero can be changed in the Mill Part Setup by selecting a vertex or arc edge, typing in the origin relative to the SOLIDWORKS zero, identifying a sketch that contains a single circle, or by picking a stock corner. When selecting a sketch, the center of the circle in the sketch will be the origin of the Mill Part Setup and program zero. Each Mill Part Setup can have a different origin.

In this tutorial, you will change the default Program Zero and use a sketch containing a circle to assign the new Program Zero.

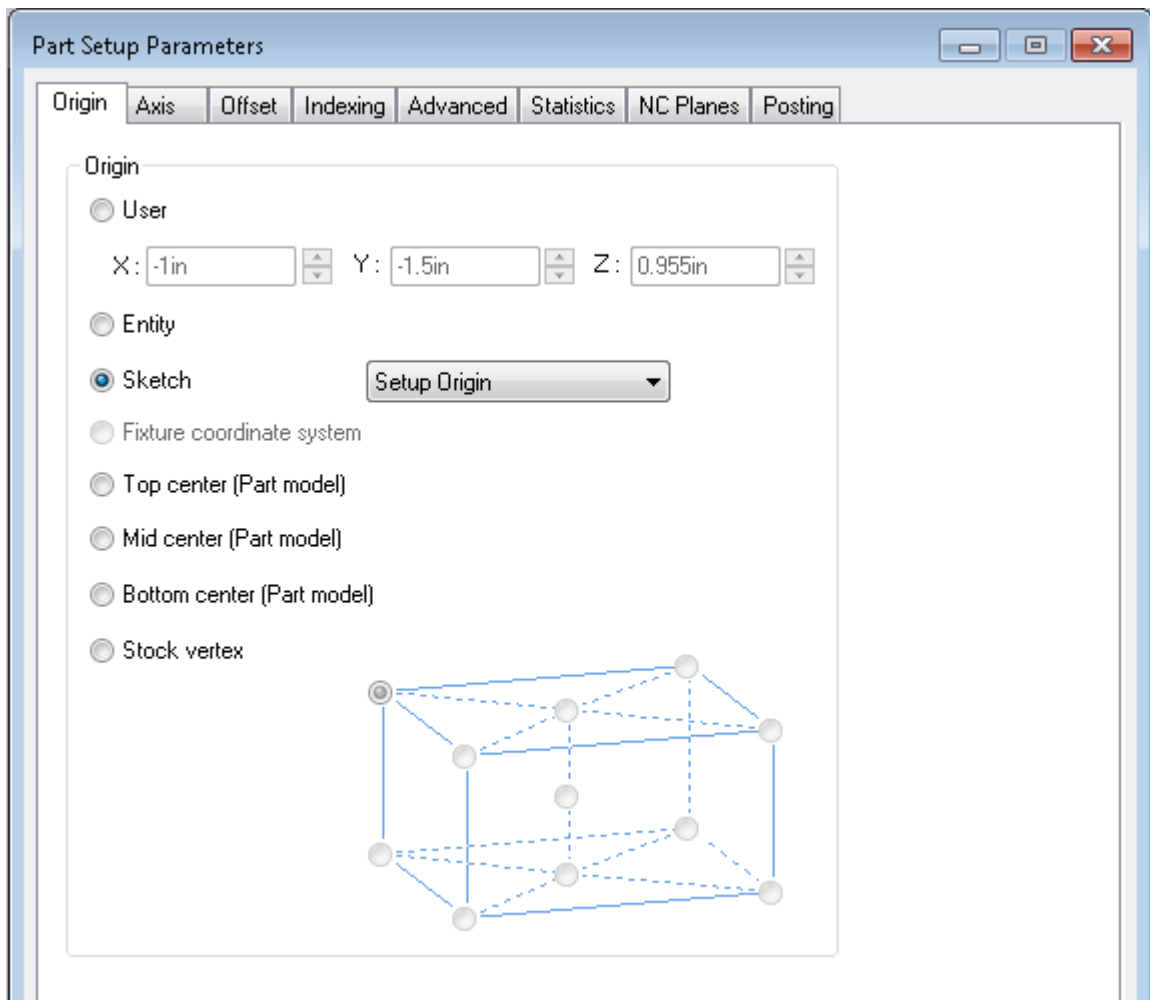

**Using a sketch containing a single circle to assign Program Zero**



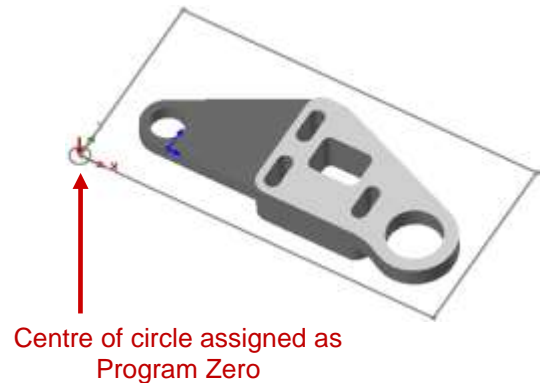

1. Double-click *Mill Part Setup1* in the Operation tree to open the *Part Setup Parameters* dialog box.
2. On the *Origin* tab, select the *Sketch* option and then select *Setup Origin* from the sketch dropdown list.
3. Click *OK* to apply the changes made and close the dialog box.  
The circle in the lower left corner of the stock is now the Mill Part Setup origin.



### **Did You Know ...**

**If you change the Mill Part Setup origin after generating toolpaths, always regenerate all toolpaths. Otherwise, the post processed output will not be relative to the new origin.**

## **Step 7: Generate and Simulate Toolpaths**

1. Click the *Generate Toolpath* button on the SOLIDWORKS CAM Command Manager  
OR  
Right click *Mill Part Setup1* in the SOLIDWORKS CAM Operation tree and select *Generate Toolpath* on the context menu.  
The font color of all the operations listed in the Operation tree changes to black indicating that toolpaths that were generated for all operations.
2. Click the *Simulate Toolpath* button on the SOLIDWORKS CAM Command Manager  
OR  
Right click *Mill Part Setup1* in the SOLIDWORKS CAM Operation tree and select *Simulate Toolpath* on the context menu.
3.  Click the *Run* button to simulate the toolpaths.
4.  Click the *Close* button to exit the simulation.

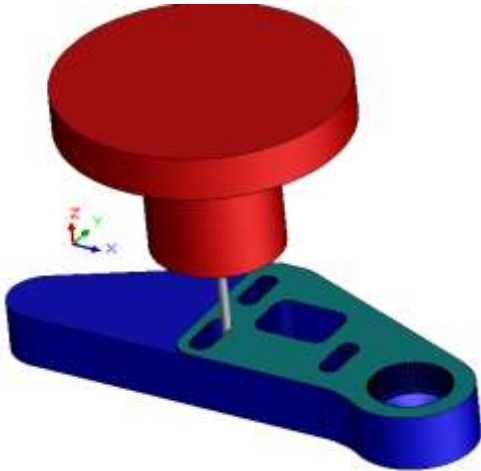

**Toolpath Simulation of Mill Part Setup1 operations**

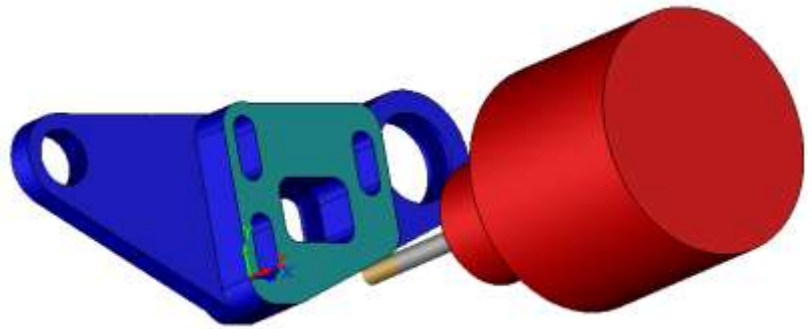

**Toolpath Simulation of Mill Part Setup2 operations**

## Step 8: Sorting Operations

When the *Generate Operation Plan* command is executed, operations are created for each feature in the Feature tree in the order listed. As shown above, operations can also be inserted manually and deleted. After making these changes, it is possible that the machining order is not in the most efficient sequence. For example, you may want all of the roughing done before the contouring, and the hole making operations to be done last. SOLIDWORKS CAM allows automatic and interactive control over changing the machining sequence. Using drag and drop, operations can be reordered into an optimized sequence. However, this could become time consuming for a part that includes dozens of operations. To make the ordering task easier, SOLIDWORKS CAM provides the *Sort Operations* command that sorts operations based on their type, depth and tool. The *Sort Operations* command provides an automatic approach.

1. Right click *Mill Part Setup1* and select *Sort Operations* from the context menu.

The *Sort Operations* dialog box will be displayed.

2. On the *Process* tab, remove the check mark from the *Process complete feature* option.

When this option is checked, all operations for a given feature will be sorted

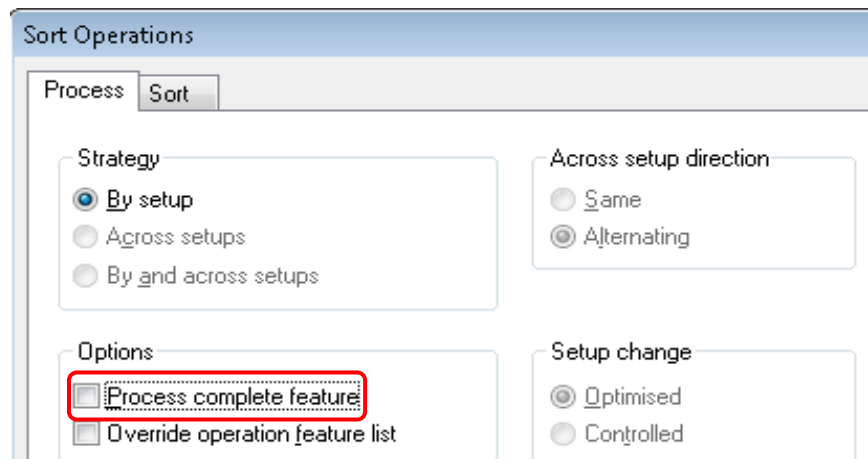

**Process Tab of Sort Operation dialog box**

and grouped together so that the entire feature is completed before processing other feature operations. After all feature operations are grouped, the order the operations are processed will be from highest Z face to lowest Z face.

3. Click on the *Sort* tab.

This tab shows the order in which the operations will be sorted. Operations can be sorted based either on the *Operation Type* or *Tool*. More information on sorting operations can be found in the SOLIDWORKS CAM context-based help.

4. In the *Sort by* dropdown list, select *Operation Type*. The operation listed in the Operation tree will be machined in order of their types. You can use the drag and drop function to sort the order of operation types listed in the *Sort by* group box.

5. In the *Then by* dropdown list, select *Tool*. All the tools used by the various operations in the selected Mill Part Setup are listed.

When multiple operations of the same operation type have to be machined, you can further sort the operations based on the tool used by the operations. Tools can be sorted either based on *Size* or *Station number*.

6. In the *Sort Tools by* group box, select the *Size* option.

When operations are sorted by Tool size, the Mill operations are ordered on the basis of their tool size from largest to smallest. For single point operations, the tool order is from the smallest to the largest diameter.

7. Click the *Apply* button.

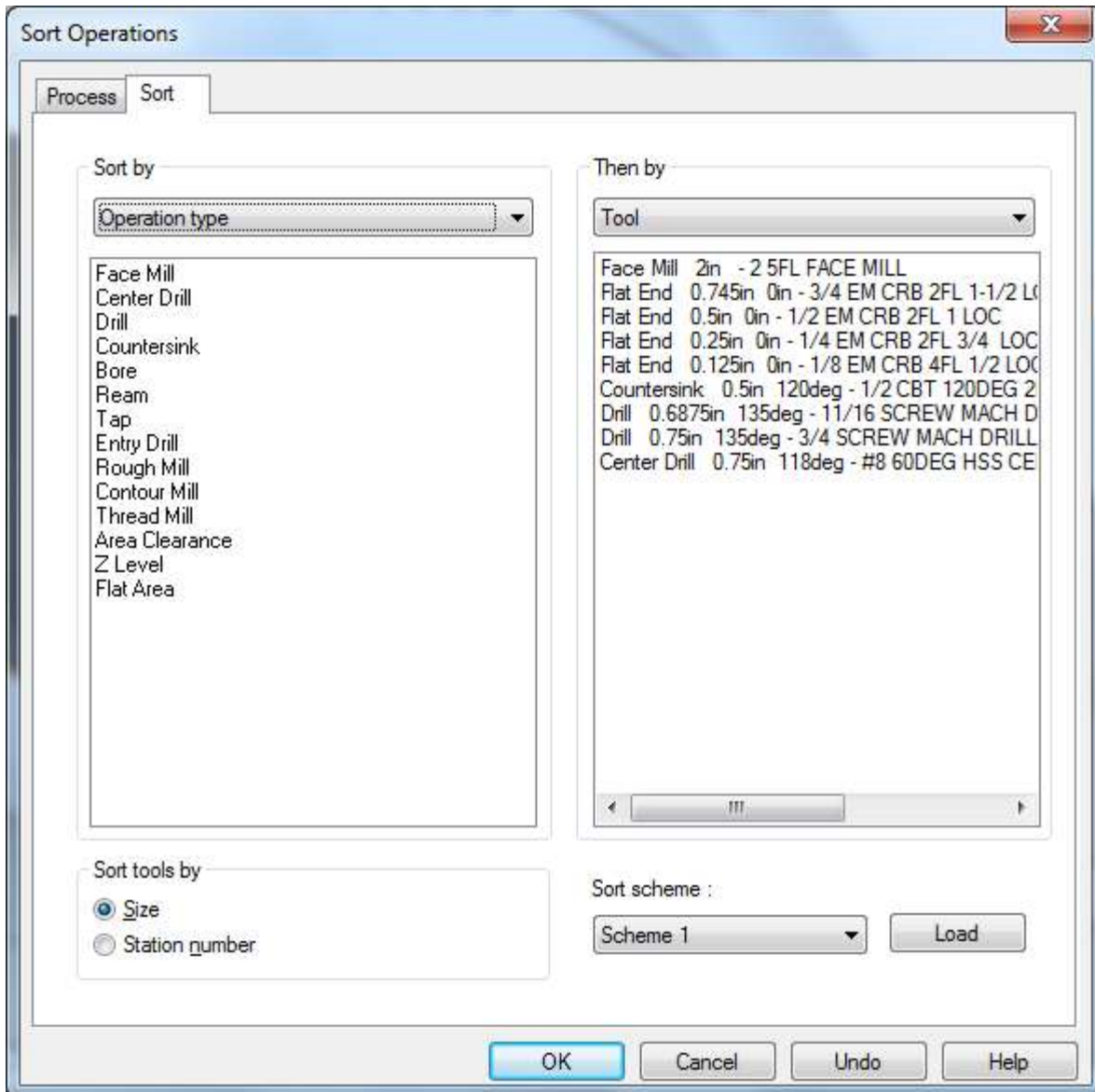

This action will sort the operations in the Operation tree according to the specified operation sequence. Within each type of operation, the operations with the highest Z face will be processed first. If you do not like the order, you can click the *Undo* button and change the order or any of the options, then click *Apply* again to see the results.



**Sort Tab of Sort Operations dialog box**

## Step 9: Simulate Toolpath and Post Process

1. Click the *Simulate Toolpath* button on the SOLIDWORKS CAM Command Manager.
2. Run the simulation and note the changes.
3. Save the part.
4. Right click *Mill Part Setup1* and select *Post Process* on the context menu.
  - The *Post Output File* dialog box will be displayed.

- 
- If you are running SOLIDWORKS CAM in Demo mode, this dialog box will not be displayed. Post processing functions works only when you have a valid license for SOLIDWORKS CAM.
5. Click *Save* to use the default name for the NC program file.  
The *Post Process Output* dialog box will be displayed.
  6.  Click the *Run* button.  
SOLIDWORKS CAM generates the NC program.
  7.  Click *Cancel* to close the *Post Process Output* dialog box.

---

## Chapter 2: Learning More 2 Axis Mill

---

This chapter provides an opportunity to learn more about SOLIDWORKS CAM 2 Axis Mill. The tutorials in this chapter are intended to show you how to use SOLIDWORKS CAM and may not correspond to actual machining practices.

The tutorial parts are installed when you install SOLIDWORKS CAM and are in the \ *SOLIDWORKS\SOLIDWORKS 201x\CAM Examples\Tutorial\_Parts\Mill* folder on your computer. (*C:\Users\Public\Public Documents\SOLIDWORKS\SOLIDWORKS 201x\CAM Examples\Tutorial\_Parts\Mill*).

Before you begin with the tutorials given in this chapter, ensure that you are through with the concepts explained in Chapter 1.

---

**IMPORTANT!** SOLIDWORKS CAM uses a set of knowledge-based rules to assign machining operations to features. The Technology Database contains the data for the machining process plans and can be customized for your facility's machining methodology. When you do these exercises, your results may not be the same as described in the steps and illustrated in the figures. This is because the machining sequences and operations data in your Technology Database may be different from the database used to produce the documentation.

---

## 2 Axis Mill 5

### Topics covered in this tutorial:



- [Setting Strategies and Generating Operations](#)
- [Sorting and Sequencing Operations](#)
- [Machining Island Tops](#)
- [Changing the Mill Part Setup Origin](#)
- [Combining Operations](#)

### Opening the Part and Extracting Machinable Features by AFR

1. Open the part file **MILL2AX\_5.SLDPRT** in the following folder.

*C:\Users\Public\Public Documents\SOLIDWORKS\SOLIDWORKS 210x\CAM Examples\Tutorial\_Parts\Mill*

Since this part is rectangular, you do not have to machine the outside of the part. AFR will find the holes, bosses, slot, corner slots and open pocket features.

2.  Click the *SOLIDWORKS CAM Feature Tree* tab.
3.  Double click *Machine [Mill–Metric]* in the Feature tree to open the *Machine* dialog box.
  - On the Machine tab, ensure *Mill–Metric* is the Active machine.
  - Click the *Tool Crib* tab and make sure *Tool Crib 2 (Metric)* is the Active tool set.
  - Click the *Post Processor* tab; make sure *M3AXIS-TUTORIAL* is selected.
  - Click *OK* to apply the changes and close the dialog box.

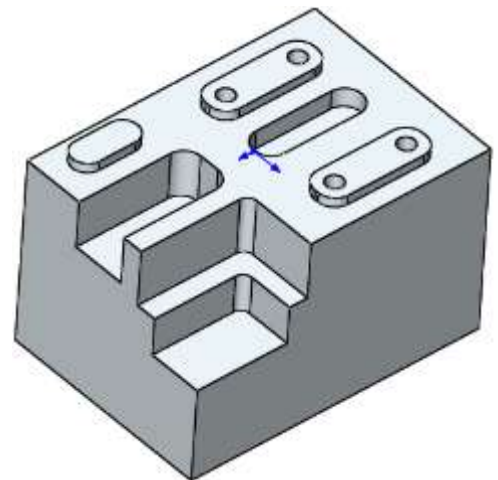



**MILL2AX\_5.SLDPRT**



#### **Did You Know ...**

**In both the Feature and Operation trees, instead of right clicking items and selecting Edit Definition, you can double-click the item to open the dialog box for editing the Stock Manager, Machine, Setups, Features and Operations.**

4.  Double click *Stock Manager* in the tree to open the *Stock Manager* dialog box.
  - Change the *Bounding box offsets* for X, Y and Z to a uniform **1mm** in all directions.
  - Leave the *Material* set to default.
  -  Click *OK* to apply the changes and close the dialog box.



5. Click the SOLIDWORKS CAM *Options* button on the SOLIDWORKS CAM Command Manager.
  - Click the *Mill Features* tab.
  - In the *Feature types* section, remove the check mark from the *Boss* option.
  - Make sure the *Face* option is **not** checked.
  - Click *OK* to apply the changes and close the dialog box.
6. Click the *Extract Machinable Features* button on the SOLIDWORKS CAM Command Manager.

**Automatic Feature Recognition** analyzes the model and extracts the features to machine. The Feature tree lists the features that were found.



**Features recognized by AFR**

- An Open Pocket feature was created with the three Obround Bosses as islands.
- The obround pocket on the top face was recognized.
- The four holes in the boss features were extracted as a group feature since they were identical in size.
- The three Rectangular Corner Slots were not extracted as a Group Feature because they are of different sizes.



### **Did You Know ...**

The default machining sequence is based on the order that the machinable features appear in the list. Using drag and drop, you could rearrange the features so that they are in the order that you would like them to be machined. However, the SOLIDWORKS CAM Operation tree allows operations to be automatically sorted and interactively sequenced (as explained below) so it is unnecessary to reorder features.

## **Setting Strategies and Generating Operations**

1. Double click *Hole Group1* in the SOLIDWORKS CAM Feature tree.
2. In the displayed *Hole Parameters* dialog box, change the Strategy to *Ream*.
3. Click *OK* to apply the changes and close the dialog box.
4. Double-click *Open Pocket1* in the SOLIDWORKS CAM Feature tree.
5. In the displayed *2.5 Axis Feature: Select Entities* dialog box, click on the *Edit Feature* button. This activates the *End Condition* button.
6. Click on the *End Condition* button.
7. The *2.5 Axis Feature: End Condition* dialog box will be displayed. In the *Strategy* dropdown list within the *2.5 Axis Feature* group box, select the *Rough-Finish* Strategy.

This strategy has been programmed to generate a Rough and Contour Mill operation for the selected feature.

8. Click the *OK* button to apply the changes and close the dialog box.

9.  Click the *Generate Operation Plan* button on the SOLIDWORKS CAM Command Manager.

SOLIDWORKS CAM creates the list of operations to machine the part. The operations for the features are sequenced in order the same order as the features listed in the Feature tree.

10. Some of the operations will have a yellow exclamation mark over them indicating that the tool assigned to those operations are not from the Tool crib. RMB on such operation and select *What's Wrong?* on the context menu. Click the *Clear* button in the displayed *Error* message to get rid of the exclamation mark.

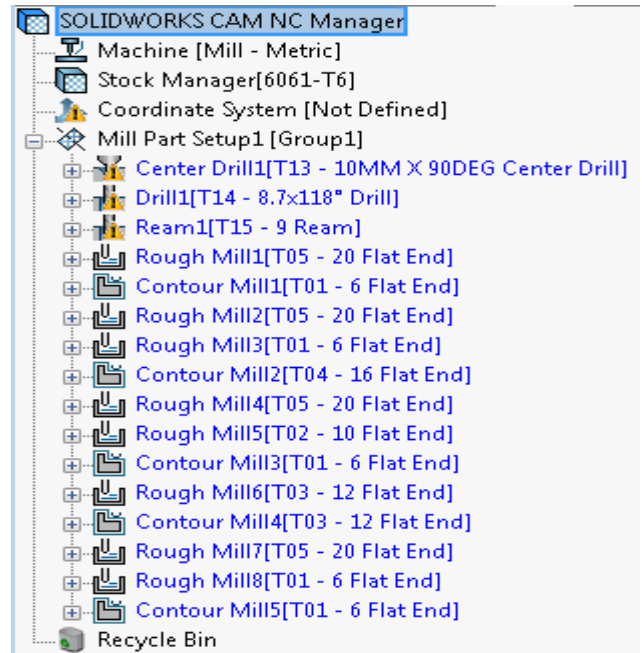

Operations generated using GOP command

## Sorting and Sequencing Operations

The machining sequence is based on the order of the operations in the tree. The Rough Mill and Contour Mill operations for the Open Pocket are listed after the hole operations. You may not want this order as it isn't very efficient.

In this tutorial, you will sequence the operations such that all of the roughing is done before the contouring, and the hole making operations to be done last.

Using the drag and drop functionality to reorder the operations is suitable only when a few changes need to be made. However, when making numerous changes to the order of the tree, the *Sort Operations* command provides an automatic approach.

In this tutorial, the machining sequence will be changed using the *Sort Operations* command.

### Steps to reorder operations using Sort Operations Command:

1. Right click *Mill Part Setup1* in the Operation tree and select *Sort Operations* in the context menu.

The *Sort Operations* dialog box will be displayed.

2. In the *Process* tab, remove the check mark in the *Process complete feature* checkbox in the *Options* group box.

When this option is checked, the operation sequence will be based on machining each feature completely before machining the next feature. The features will be sorted from highest Z to lowest Z.

- Click on the *Sort* tab. Select Sort by *Operation Type* in the dropdown list.

The Sort tab allows operations to be sorted based on either one or two criteria- *Operation Type* or *Tool*. The *Sort by* list shows the current order for sorting operations. The default order is defined in the Technology Database and can be modified as required.

- Click the *Apply* button to see the result of the current sorting rules.

The operations in the tree are sorted according to the order in the list.

- Click the *Undo* button to return to the original order.

- In this tutorial, you want to sort by operation type with the Rough Mill cycles first, Contour Mill cycles second and then the hole making cycles. To do this, you can use drag and drop to reorder the operation list.

- Select *Rough Mill* in the list and drag it below *Face Mill*. Since there is no *Face Mill* operation in the operation tree for this part, positioning the *Rough Mill* cycle below *Face Mill* does not matter.
- Select *Contour Mill* and drag and drop it below *Rough Mill*.
- Ensure that *Center Drill*, *Drill*, *Countersink*, *Bore* and *Ream* operations are listed below Contour Mill operation necessarily in the same order as it is given here.

- Click the *Apply* button. The order in the tree changes to reflect the current operation list.

- Click *OK* to commit the changes and close the dialog box.

The order of the operations in the Operation tree can be further modified using drag and drop functionality if necessary.

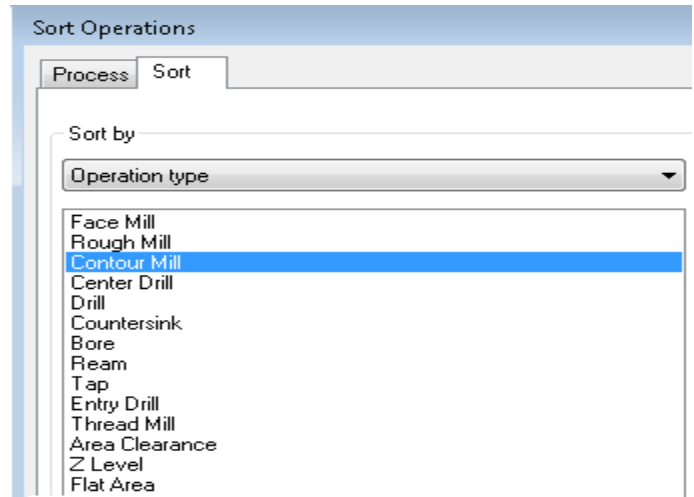

**New Sorting Sequence**

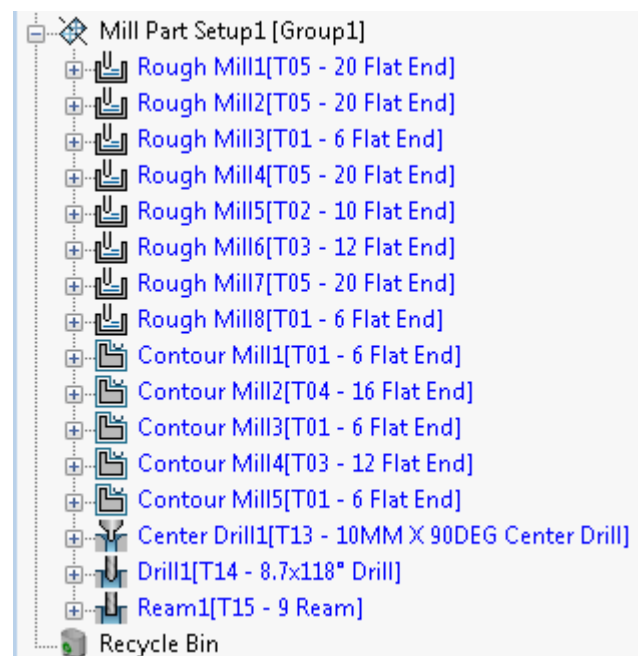

**Operations after sorting**

**CAUTION!**

Be careful when dragging and dropping the operations. Make sure you do not change the order so that the tools will cause a crash. For example, you could drag the ream operation in front of the drill operation. SOLIDWORKS CAM assumes that you know what you are doing and will process the toolpaths exactly the way you have them ordered.

## Machining Island Tops

To recap what was explained in the previous tutorials, the *Operation Parameters* dialog box allows you access to all the parameters that will be used to machine a feature. You can change parameters to customize the toolpath that SOLIDWORKS CAM generates to suit your machining requirements.

**Did You Know ...**

The parameters that you change in the *Operation Parameters* dialog box are used only for the current operation. Other operations and other parts will revert to the default parameters that are defined in the *Technology Database*.

In this tutorial, you will change the operation parameters for the Rough Mill operation used to machine the Open Pocket feature so that the following occur:

- The Pocketing pattern creates parallel lace cuts with the cuts alternating in direction. Between each lace cut, the tool stays down in the material. (Zigzag pattern)
- The islands within this Open Pocket are faced off.

**Steps to activate option for Machining Island Tops:**

1. Double click *Rough Mill* (the operation for Open Pocket) in the Operation tree to open its corresponding *Operation Parameters* dialog box.
2. Click the *Roughing* tab in this dialog box.
3. Change the Pocketing Pattern to *Zigzag*.  
This option creates parallel lace cuts with the cuts alternating direction. Between each lace cut, the tool stays down in the material.
4. In the *Pocketing* group box, ensure that the checkbox option *Machine island top* is enabled so that the islands on the top of the part are faced off.
5. Click *OK* to apply the changes and close the dialog box.

## Changing the Mill Part Setup Origin

SOLIDWORKS CAM creates Mill Part Setups automatically during *Automatic Feature Recognition* with the *Mill Part Setup depth* set to the highest face on the recognized features and the *Mill Part Setup origin* is set on the edge of the first recognized feature on the top of the part.

This *Mill Part Setup origin* defines the G-code program zero location using the machine tool's fixture location, Work Coordinates and/or Sub Coordinate offsets. The Mill Part Setup

origin position is based on the SOLIDWORKS origin. You can move the Mill Part Setup origin to a more useful location for machining.

1. Click on *Mill Part Setup1* in the Operation tree.

Notice where the origin is located on the center of the top face of the part. It is in sync with the SOLIDWORKS origin.

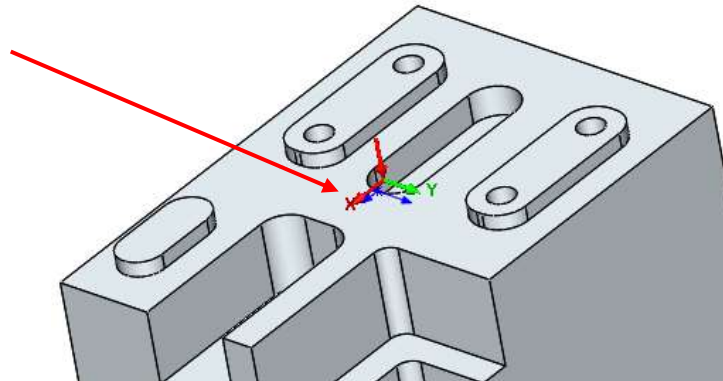

**Locating the Mill Part Setup Origin**

2. Double click *Mill Part Setup1* in the Operation tree in order to open the *Part Setup Parameters* dialog box.
3. In the *Origin* tab, select the *Stock vertex* option.
4. Pick the corner as shown in the below image.
5. Click *OK* to apply the changes and close the dialog box.
6. Click on the *Mill Part Setup1* and observe the part in the graphics area.

The origin of the Mill Part Setup is moved on the part to the corner you selected.

Based on the orientation of the part, selecting a corner in the dialog box may not appear to be the same corner on the part. This is because the model can be rotated to any position in space.

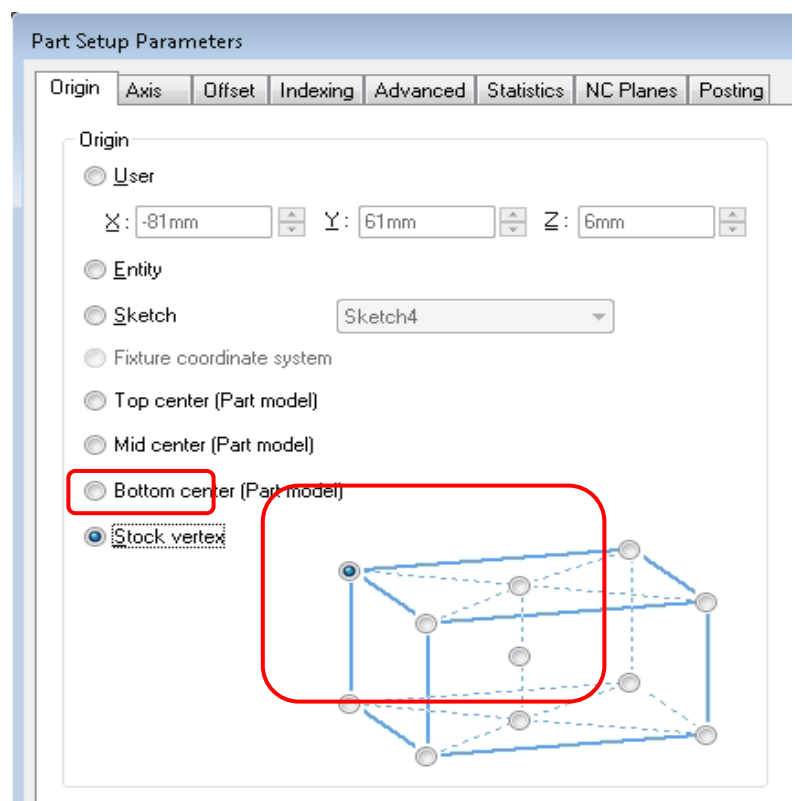

**Changing Mill Part Setup Origin to a stock vertex**

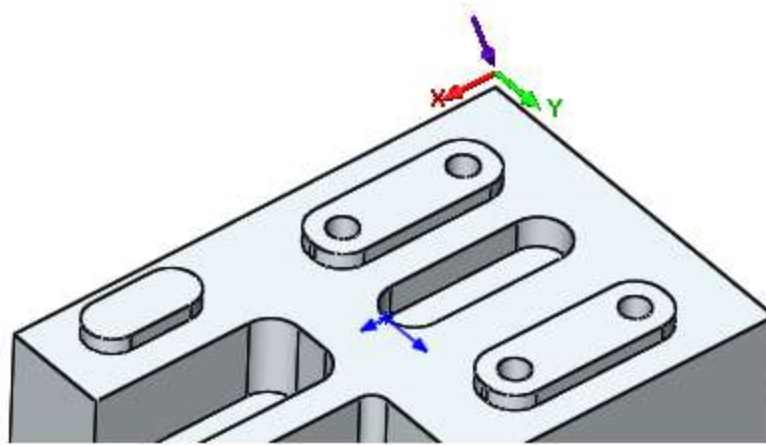

**New Mill Part Setup Origin at selected stock vertex**

## Combining Operations

Notice that several roughing and contouring operations use the same tool. Similar operation types that use the same tool can be combined into one operation in order to improve efficiency.

### Steps to combine operations:

1. In the Operation tree, right-click on *Mill Part Setup1* in the tree and select *Combine Operations* command from the context menu.

The Combine Operation dialog box will be displayed.

2. Select *Rough Mill* and *Contour Mill* from the list.
3. Ensure that the *Regenerate Toolpath* option is checked.
4. Click *OK* to apply the changes and close the dialog box.

SOLIDWORKS CAM combines similar Rough Mill operations that use the same tool. Same applies to the Contour Mill operations too.

5. Click the next to the *Rough Mill1*, *Rough Mill3*, *Rough Mill5* and *Contour Mill1* operations in the Operation tree to expand these items.

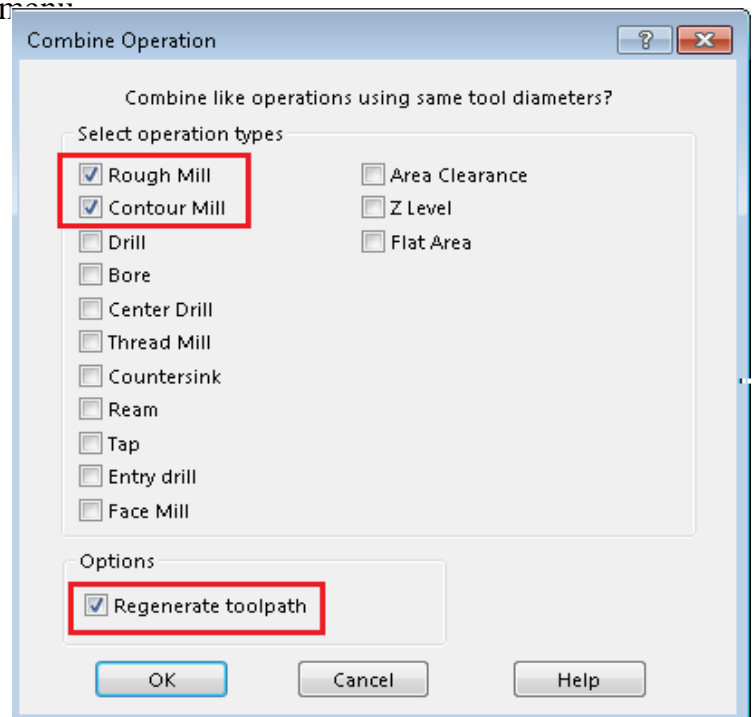

**Combine Operation dialog box**



Observe that the operations which use the same size tool were combined. Notice that the order of the operations was maintained. The rough operations are first, followed by the contour operations, and finally the hole operations.



### Did You Know ...

After toolpaths have been generated, if you combine operations and disable the Regenerate toolpath option in the Combine Operations dialog box, you must generate toolpaths again.

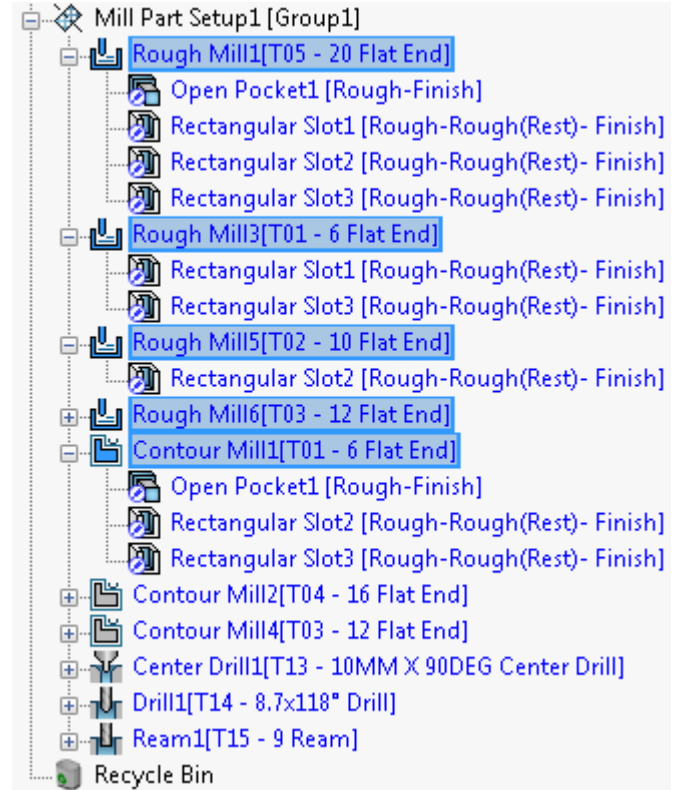

Operations after combining

## Changing Tool Parameters and Generating Toolpath

1. Double click *Drill1* in the Operation tree.
2. Click on the *Tool* tab.
3. On the Drill Tool page, change the *Overall length* to **150mm**.
4. On the Mill Holder page, change the *Protrusion* to **130mm**,
5. Click *OK* to apply the changes and close the dialog box.

6. Click the *Generate Toolpath* button on the SOLIDWORKS CAM Command Manager.

OR

Right click the *Mill Part Setup1* in the Operation tree and select *Generate Toolpath* in the context menu.

7. Highlight the first operation in the tree, hold down the *Shift* key, then highlight the last operation. This action selects all the operations and highlights all the toolpaths on the part in the graphics area.



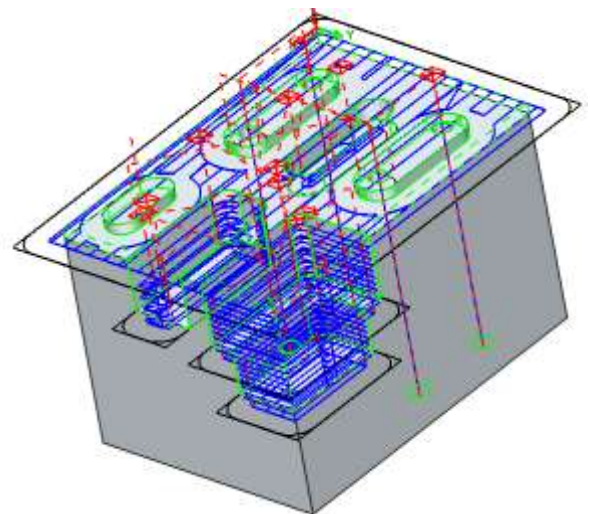

Your model should look similar to the figure on the right.



Toolpaths generated for all operations



## Simulate Toolpath and Post Process

1. Click on the *Simulate Toolpath* button on the SOLIDWORKS CAM Command Manager.
2.  Click the *Run* button on the toolbar to start the simulation.
3.  Click the *Return* to start button.
4.  Click the *Turbo mode* button, and then click *Run*.
5. The simulation does not update the stock until the simulation is completed. This is the fastest method for simulation.
6.  Click the *Close* button in the upper right corner of the Simulate Toolpath toolbar to exit simulation mode.
7. Right click on the *Mill Part Setup1* and select *Post Process* on the context menu.
8. The Post Output File dialog box is displayed so you can name the NC program file.
9. Use either the default file name or type a different name and save the file.
10. Click the  *Run* button in the Post Process Output dialog box to output the G-code file.
11. Click *OK* to close the dialog box.

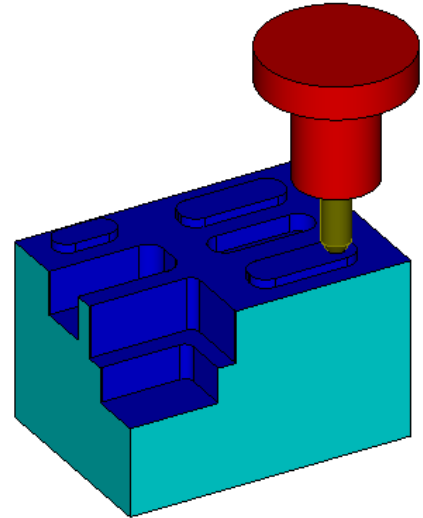

**Simulate Toolpath**

## 2 Axis Mill 6

### Topics covered in this tutorial:

- [Interactively inserting 2.5 Axis Features](#)
- [Avoiding Clamps](#)
- [Modifying Operation Parameters and Toolpaths](#)
- [Customizing Toolpaths](#)



This tutorial involves the machining of a non-rectangular solid part that requires several features to be interactively inserted.

### Opening the Part

1. Open the part file **MILL2AX\_6.SLDPRT** in the following folder.

*C:\Users\Public\Public Documents\SOLIDWORKS\SOLIDWORKS 201x\CAM Examples\Tutorial\_Parts\Mill*

Since this part is non-rectangular, a feature to machine the outside of the part has to be inserted. In addition, a feature will be added to cut the top of the pockets. All machining will be from the top of the part.

2.  Click the *SOLIDWORKS CAM Feature Tree* tab.
3.  Double click *Machine [Mill-Metric]* in the Feature tree to open the *Machine* dialog box.
  - On the *Machine* tab, set *Mill-Metric* as the Active machine.
  - Click the *Tool Crib* tab. In the Available tool cribs list box, ensure that *Tool Crib 2 (Metric)* is the Active tool crib.
  - Click the *Post Processor* tab and make sure *M3AXIS-TUTORIAL* is selected.
  - Click *OK* to apply the changes and close the dialog box.

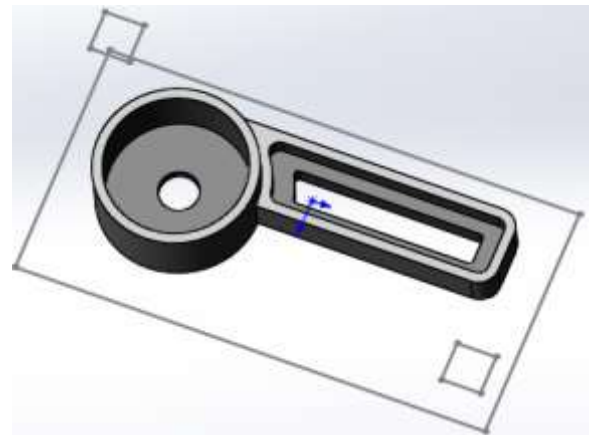

**MILL2AX\_6.SLDPRT**

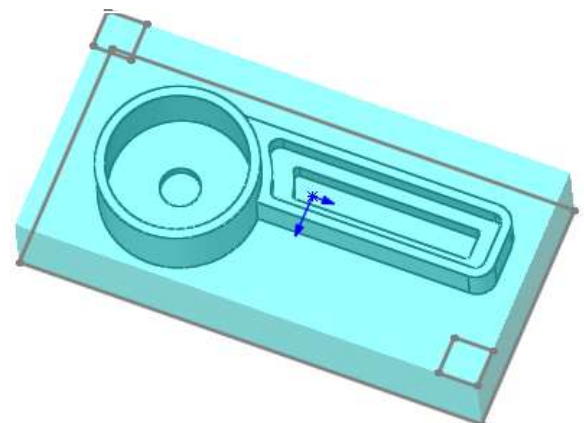

**Defining Stock using Extruded Sketch**

## Defining Stock

1. In the Feature tree, double click the *Stock Manager* item in the Feature tree.
2. The *Stock Manager* dialog box will be displayed.
3. Under *Stock Type*, click on the *Extruded Sketch* button.
4. In the graphics area, pick the sketch representing the stock.
5. The *Stock* sketch will be listed in the Sketch field.
6. Set the Depth to **45mm**.
7. If the stock doesn't extrude in the correct direction, click the *Reverse Direction* button.
8. Click *OK* to apply the changes and close the dialog box.

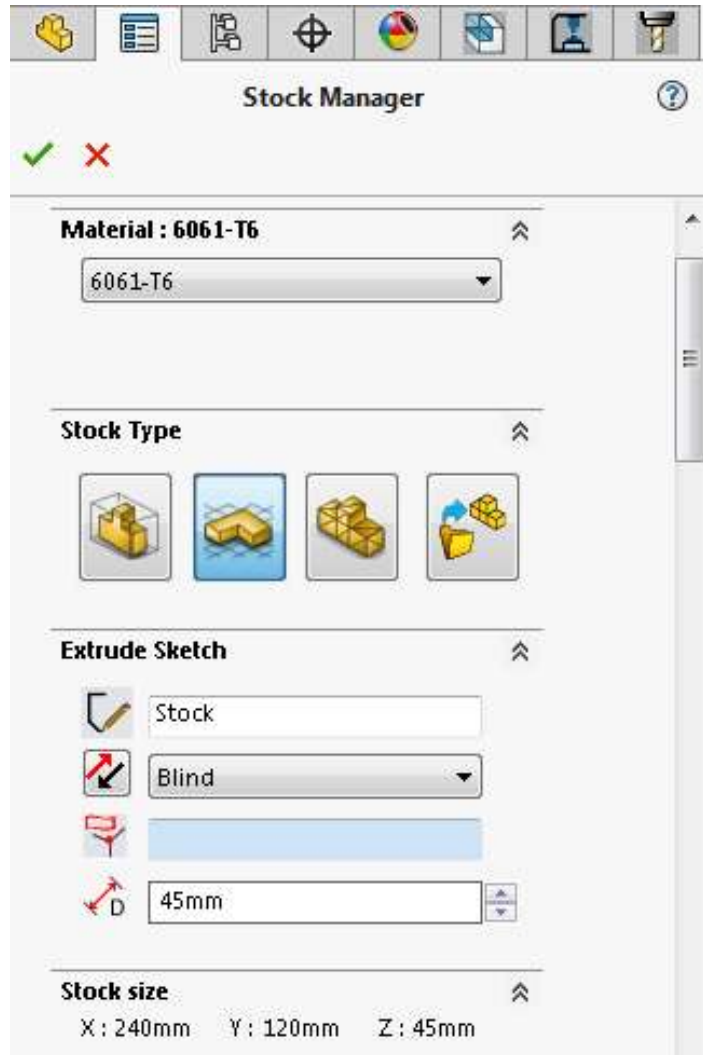

**Stock Manager Dialog Box**

## Defining Fixture Coordinate System of the Mill machine

The next step is to define the Fixture Coordinate System of the selected machine. Following are the steps:

1. In the Feature tree, double click on the *Coordinate System* item.
2. The *Fixture Coordinate System* dialog box will be displayed.
3. Set the *Method* to *User Defined*.
4. In the *Origin* group box, select the option *Stock bounding box vertex*.
5. This action will display all the vertices associated with the stock bounding box in the graphics area.

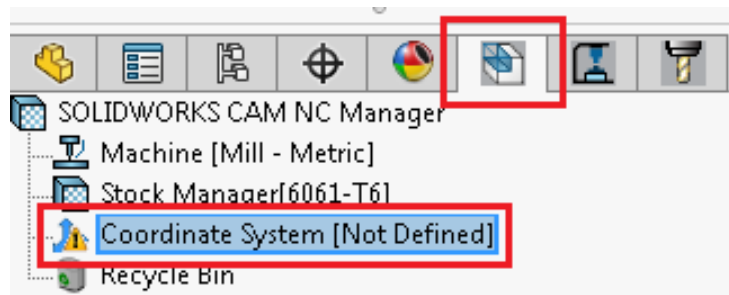

**Double-click "Coordinate System" item in the Feature tree**

- Select the top corner vertex (highlighted in blue) from the graphics area as shown in the image below:

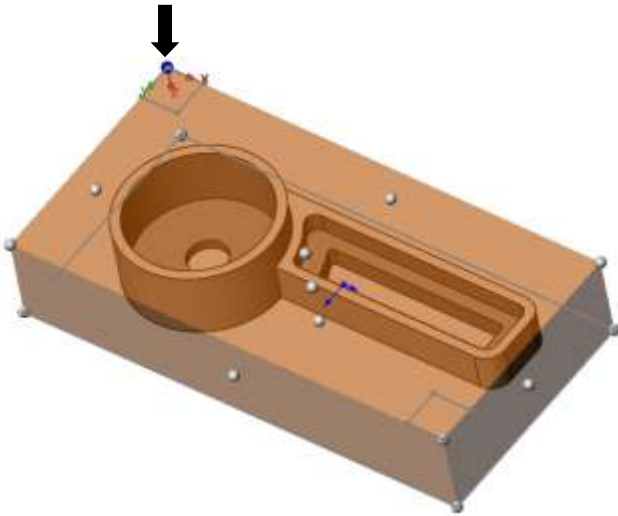

- Click on the *OK* button to configure the FCS and close this dialog box.  
The Fixture Coordinate System is now configured.

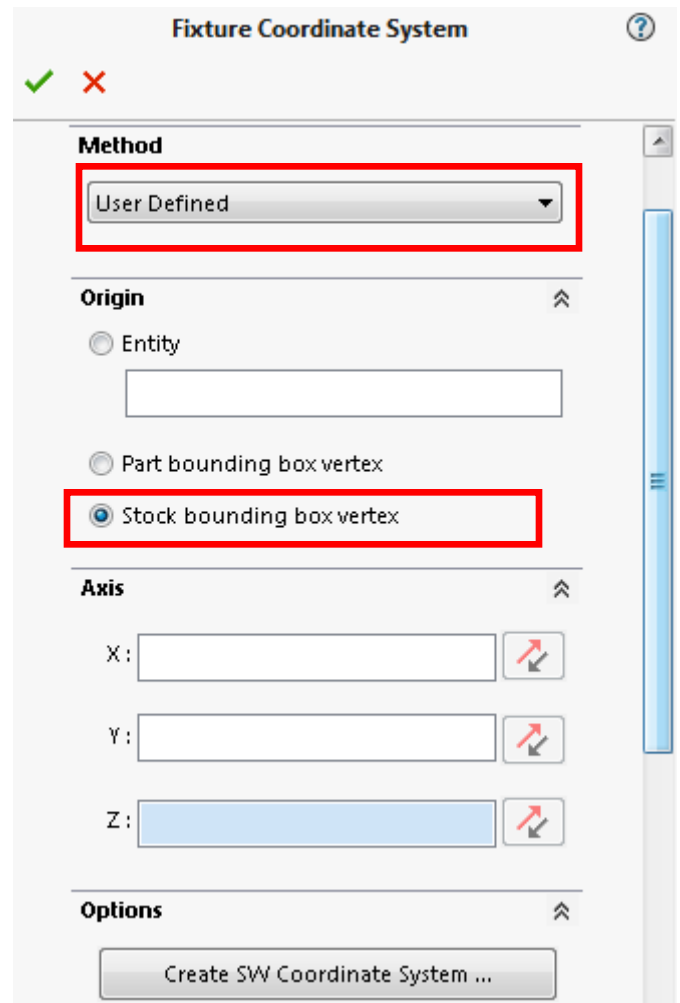

**Fixture Coordinate System Dialog Box**

## Automatic Feature Recognition Settings

- On the *SOLIDWORKS CAM Command Manager*, click the *SOLIDWORKS CAM Options* button.  
In case this button is not visible on the Command Manager, click on the *Expand view* button on the extreme right hand side of the *SOLIDWORKS CAM Command Manager*. The *SOLIDWORKS CAM Options* button will be displayed in the dropdown list.
- On clicking this button, the *Options* dialog box will be displayed. Click on the *Mill Features* tab.
- Under the *Feature Types* group box, ensure that the following options are checked:
  - Holes
  - Non holes
  - Face
  - Part Perimeter
- Click *OK* to apply the changes and close the dialog box.

## Extracting Machinable Features

1. On the SOLIDWORKS CAM Command Manager, click the *Extract Machinable Features* button.
2. The recognized features will be listed under the SOLIDWORKS CAM Feature tree under *Mill Part Setup1* and *Mill Part Setup2*.

The Face Feature (for the bottom face of the part), the Perimeter feature, one Irregular Pocket Feature and a Hole feature are recognized under *Mill Part Setup1*. The remaining features which can be machined from the top of the part are listed under *Mill Part Setup2*. You can highlight each of these feature items in the Feature tree to view the corresponding machinable feature in the graphics area.

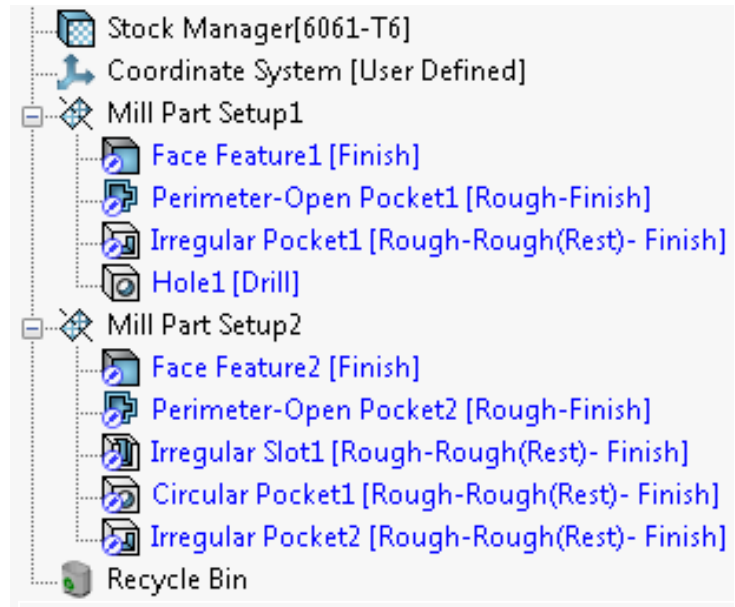

**Features recognized using EMF command**

## Renaming Mill Part Setups

1. Right-click *Mill Part Setup1* and select *Rename* from the context menu. Rename it to *Bottom Part Setup*.
2. Right-click *Mill Part Setup2* and select *Rename* from the context menu. Rename it to *Top Part Setup*.

## Rearranging features using Drag and Drop Functionality

1. Under *Bottom Part Setup*, drag and drop the *Face Feature1* item on to the *Perimeter-Open Pocket1* item. This action repositions it under *Perimeter-Open Pocket1* so that it is listed as the second item under this setup.
2. Under *Top Part Setup*, drag and drop the *Face Feature2* item on to *Perimeter-Open Pocket2* in order to reposition it under *Perimeter-Open Pocket2* so that it is listed as the second item under this setup.
3. Highlight the *Bottom Part Setup* and drag and drop it on the *Top Part Setup*.
4. The renamed and rearranged Mill Part Setups and their associated features are shown in adjacent image.

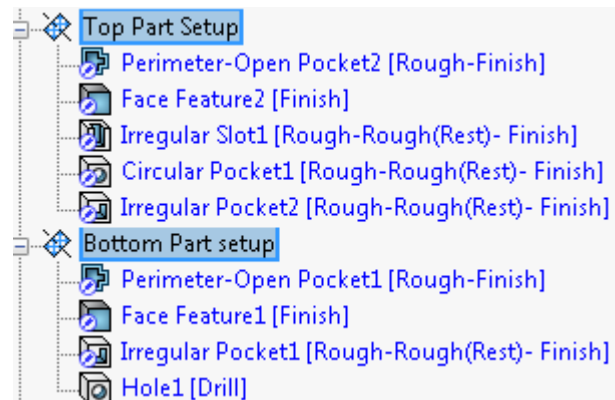

**Mill Part Setups after renaming**

## Generating Operations

Click the *Generate Operation Plan* button on the SOLIDWORKS CAM Command Manager.

OR

Right click on *Top Part Setup* and select *Generate Operation Plan* from the RMB context menu.

The Operations list should look similar to the image below.

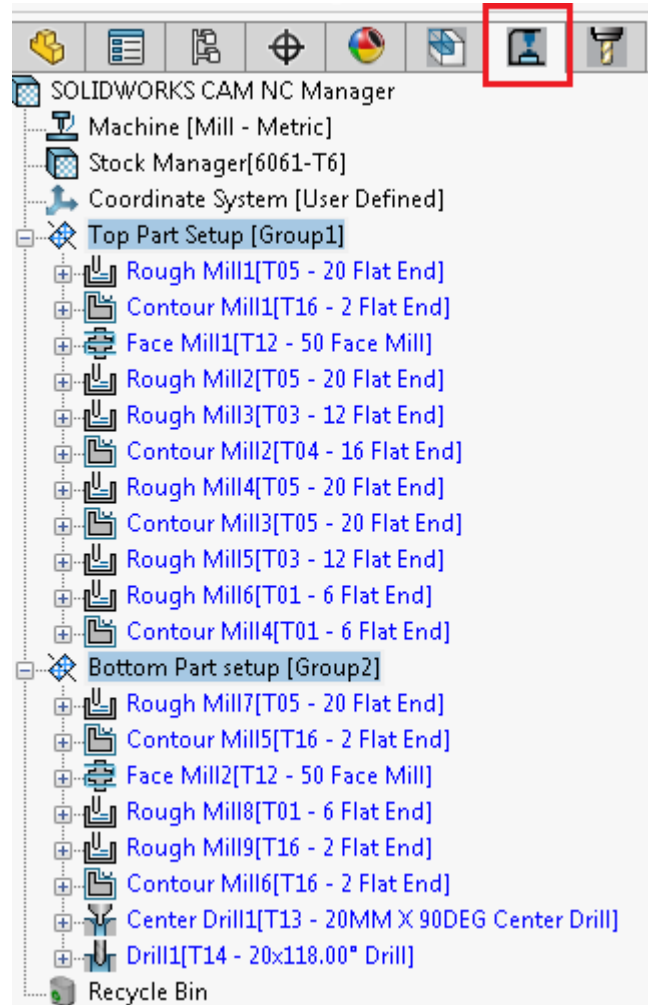

**Operations generated on executing 'Generate Operation Plan' Command**

## Defining Avoid Areas for Clamps

Rough, Contour and Face Mill operations for 2.5 Axis Mill features can be modified by specifying Avoid Areas. Avoid areas can be used as a definition for clamps and large holes in the feature where machining is to be avoided. Avoid areas can be defined from planar or non-planar model edges and faces, as well as from sketches. Avoid Areas are considered to be islands within the perimeter and will be machined around leaving material equal to the sum of the Side allowance and Avoid allowance parameters.



In this tutorial, we will define avoid areas for the Face Feature and the Perimeter Open Pocket feature listed under the *Top Part Setup* to avoid machining the clamps.

**Following are the steps:**

1. In the Operation tree, right In the Operation tree, click *FaceMill1* under the *Top Part Setup* and select *New Avoid Area* on the RMB context menu.  
The *Avoid Area* dialog box will be displayed.
2. In the Selection Mode group box:
  - Select *Adjacent Faces* in the Face Selection dropdown list.
  - Select *Single Edge* in the Edge Selection dropdown list.
3. In the *Allowed Sketches* list, select *Clamp 1* and *Clamp 2* from the list. This action selects these sketches to the *Selected Contours* list box.
4. In the Shape group box, select *Multiple*. This allows you to create multiple avoid areas from the selected entities.
5. Click *OK* at the top left corner of the dialog box to insert the Avoid Area and close the *Avoid Area* dialog box.
6. Click the (+) plus sign next to *Face Mill1* in the Operation tree. The Avoid Area will be listed under the Face Mill operation.

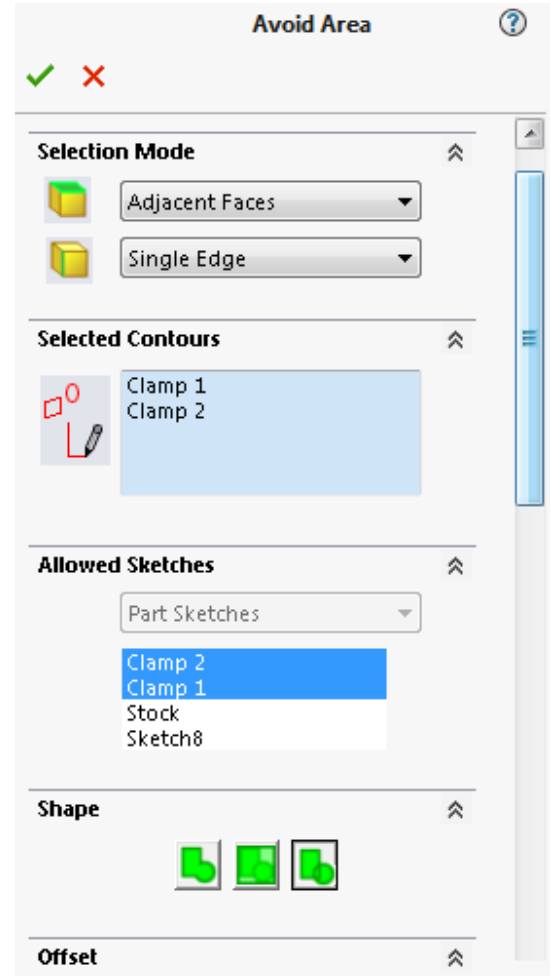

**Avoid Area dialog box**

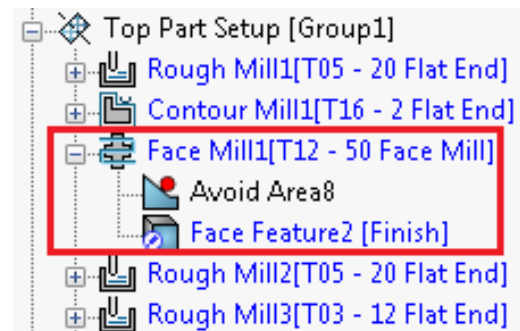

**Avoid Area for Face Mill Operation**

**Copying Avoid Areas from one Operation to another**

You can copy avoids to other operations within the same Mill Part Setup. In this tutorial, we will copy the inserted Avoid Area as the Avoid Area for the Rough Mill operation (*Rough Mill1*) of the Part Perimeter feature under *Top Part Setup*.



Following are the steps:

1. In the Operation tree, expand the *Face Mill1* by clicking on the (+) plus sign adjacent to it. The Avoid Area will be listed under the Face Mill operation.
2. Highlight *Avoid Area1*, press the Ctrl key on the keyboard and then drag the Avoid area on top of *Rough Mill1*.



If you do not press the Ctrl key while dragging and dropping, then a copy of the Avoid Area won't be created. Instead, the Avoid Area will shift from one operation to another.

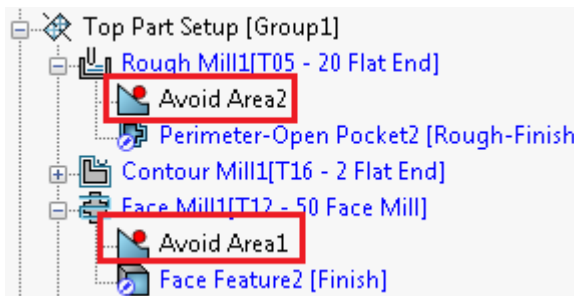

Avoid area copied from one operation to another

## Modifying Operation Parameters before Generating Toolpaths

Before generating toolpaths, we will modify some of the operation parameters. Typically, choosing parameters for machining is based on personal preference.

### Changes to parameters of Face Mill operation

1. In the Operation tree, under *Top Part Setup*, double click *Face Mill1* to open the *Operation Parameters* dialog box.
2. Under the *Tool Crib* page of the *Tool* tab, click the *Add* button to select a new tool from the Tool library.
3. The *Tool Select Filter* dialog box will be displayed. Leave the Tool type set to *Face Mill*.
4. In the Tool Database (metric) form at the bottom of this dialog box, select a **100mm** diameter tool and click the *OK* button.

This action closes the *Tool Select Filter* dialog box and adds the selected tool to the active Tool crib. The new tool will listed at the bottom of the Tool Crib grid.

**Tool Select Filter**

Tool type : **Face Mill**

**Filter by**

- Diameter: 0mm - 9mm
- End Radius: 0mm - 9mm
- Tool material: Carbide
- Holder Designation: BT-30
- Protrusion Length: 0mm - 9mm

**Preview**

**Mill (Metric)**

	ID	ToolID	ToolDia	BodyDia	EffectiveCutLen	BodyLen	OverallLen	ShankDia
1	1	40MM FACE MILL	40.000000	48.200000	3.200000	35.000000	40.000000	38.000000
2	2	50MM FACE MILL	50.000000	58.200000	3.200000	35.000000	40.000000	38.000000
3	3	63MM FACE MILL	63.000000	71.200000	3.200000	35.000000	40.000000	50.000000
4	4	80MM FACE MILL	80.000000	88.100000	3.200000	45.000000	50.000000	60.000000
5	5	100MM FACE MILL	100.000000	108.100000	3.200000	45.000000	50.000000	80.000000
6	6	125MM FACE MILL	125.000000	133.100000	3.200000	55.000000	63.000000	90.000000

Select 100MM tool from the Tools Database list

- On the Tool Crib tab, scroll down the list of tools and highlight the **100mm** Face Mill tool and click *Select*.

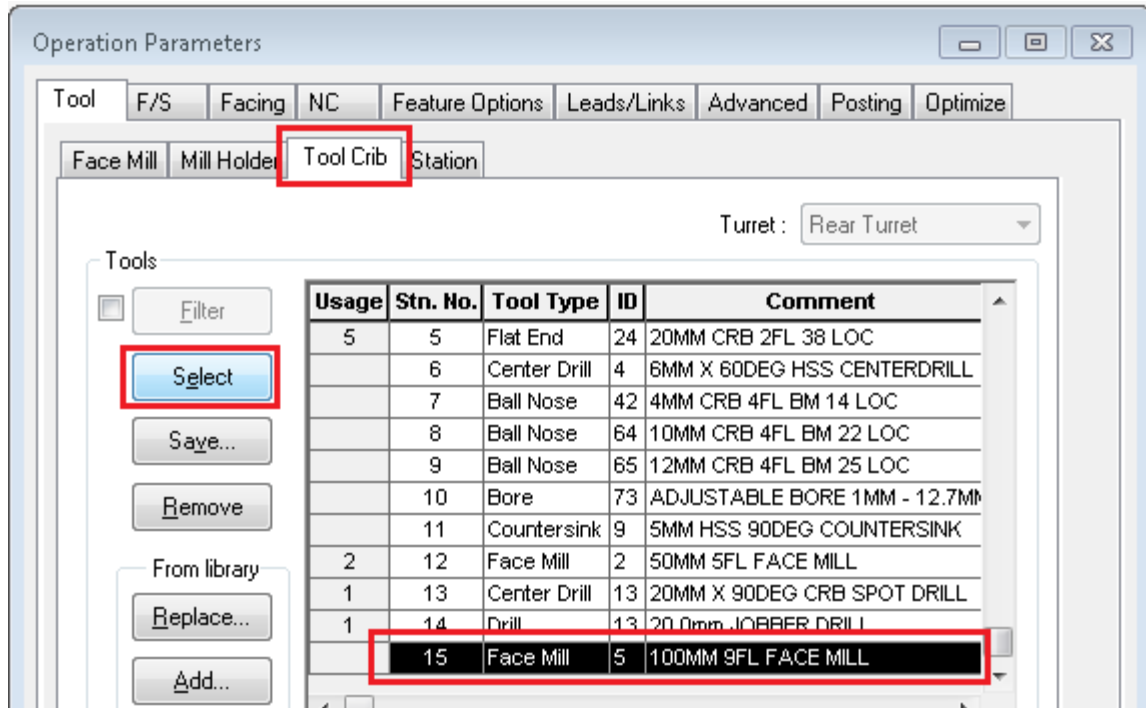

**Tool Crib page under tool tab**

6. Click *Yes* when SOLIDWORKS CAM displays a warning message indicating whether the corresponding holder is also to be replaced or not.
7. Click *OK* to apply the changes and close the Operation Parameters dialog box.

### Changes to parameters of Rough Mill operation for Part Perimeter Feature

1. In the Operation tree, under *Top Part Setup*, double click *Rough Mill1* in the tree. This is the Rough Mill operation for the Part Perimeter feature.
2. The Operation Parameters dialog box for this operation will be displayed. On the Tool tab, click on the *Mill Tool* page. Change the Flute Length to **20mm**.
3. Click on the Roughing tab.
  - a. In the *Pocketing* group box, ensure that the *Cleanup pass* option is not checked.
  - b. In the *Depth Parameters* group box, change the Bottom allowance to **4.5mm**  
 The stock has been defined in such a way that the bottom of the part is 5mm off the bottom of the stock. When machining the Perimeter feature, if the Bottom allowance is 5mm or slightly less, then a skin will remain to hold the part to the clamp.
4. Click on the *OK* button to apply the changes and close the Operation Parameters dialog box.
5. SOLIDWORKS CAM will display a message indicating that tool parameters have changed. Click on the *Change* button within this message box to apply the changes to all other operations sharing this tool.

### Changes to parameters of Contour Mill operation for Part Perimeter Feature

1. Double click *Contour Mill1* in the Operation tree. This is the Contour Mill operation for the Part Perimeter feature.
2. The Operation Parameters dialog box for this operation will be displayed. Click the *Contour* tab within this dialog box.
3. By default, the depths of cut will produce multiple contour cuts. In the *Depth Parameters* group box:
  - a. Ensure that the value for the *First cut amt.* is **50mm**.
  - b. Change the assigned value for *Allowance* to **4.5mm**. (Similar to Rough Mill4, this Allowance allows the part to remain attached to the stock.)
4. In the *Depth processing* group box, select the *To Depth by region* option.

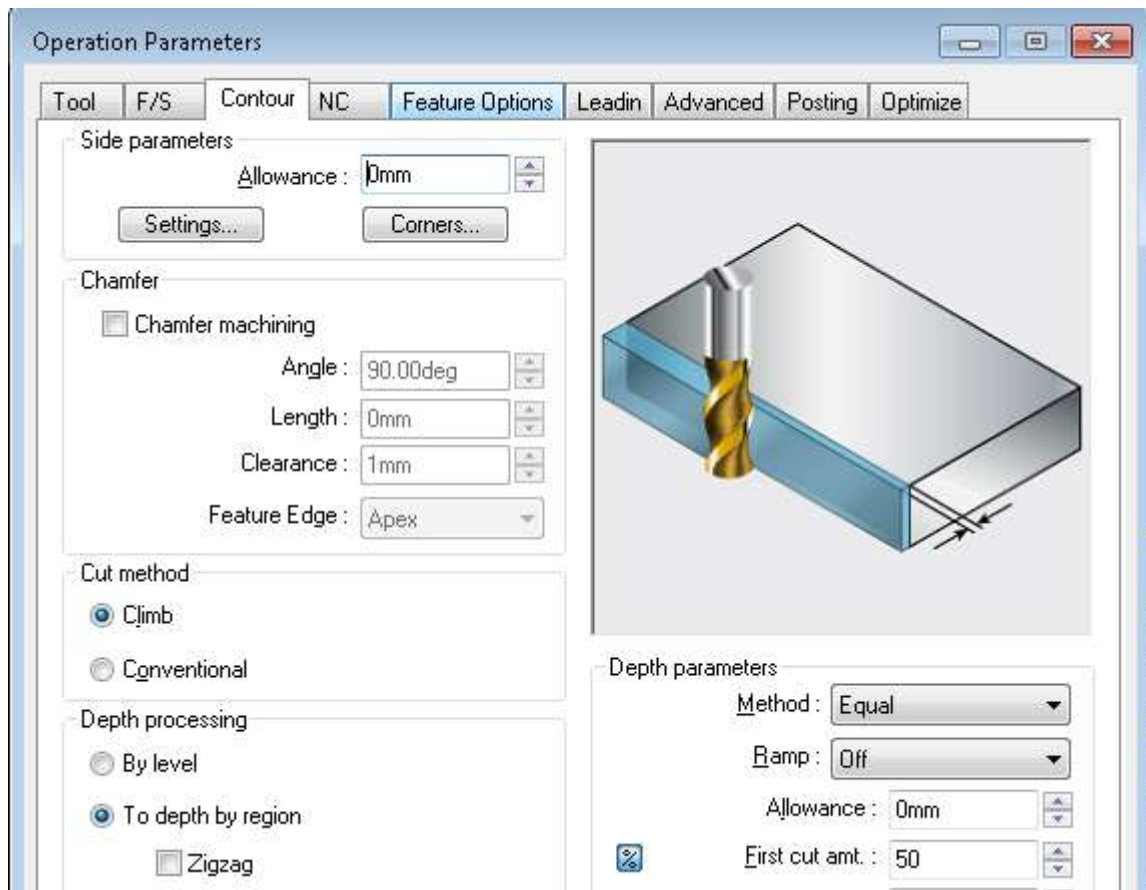

**Contour Tab of Operation Parameters dialog box**

5. Click *OK* to apply the changes and close the Operation Parameters dialog box.

### Changes to parameters of Contour Mill operation for Circular Pocket Feature

1. The default values assigned to the operation parameters for the Circular Pocket feature produce more cuts than are needed. You can edit the operation and change the values.
2. Double click *Contour Mill3*. This is the Milling operation for the Circular Pocket.
3. The Operation Parameters dialog box will be displayed. Click on the *Contour* tab and change the following parameters:
  - a. In the Depth Parameters group box, change the First cut amt. to **10mm** and Max cut amt. to **10mm**.
  - b. In the *Side Parameters* group box, click the *Settings...* button. The *Side Parameters* dialog box will be displayed.
  - c. Change the *Cut amt* to **10mm**.
  - d. Click *OK* to apply the changes and close this dialog box.
4. Click the OK button to close the Operation Parameters dialog box.

### Changes to parameters of Contour Mill operation for Irregular Pocket Feature

For this operation, the 6 mm Flat End tool will be replaced with a 2mm Flat End tool .

1. Double click *Contour Mill4* in the tree. This is the Contour Mill operation for the *Irregular Pocket2* feature. The corresponding *Operation Parameters* dialog box will be displayed.
2. Click on the *Tool* tab. Under this tab, click on the *Tool Crib* page.
3. Scroll through the list of tools in the Active Tool crib and select a **2mm** Flat End and click *Select* button.

If a 2mm Flat End Mill is not listed in this page, then following are the steps:

- a. Click on the **Add** button within the Tool Crib page.
  - b. Clicking on the *Add* button displays the *Tool Select Filter* dialog box.
  - c. Set the Tool type to *Flat End*.
  - d. In the list of displayed Flat End tools at the bottom of this dialog box, highlight a 2mm tool and click the OK button.
  - e. The *Tool Select Filter* dialog box will close. The selected 2mm Flat End mill tool will be displayed at the bottom of the list in the Tool Crib page.
  - f. Highlight the tool and click on the *Select* button.
  - g. SOLIDWORKS CAM will display a warning message prompting you to indicate whether corresponding holder is o also be replaced. Click *Yes* within this message box to replace the holder.
4. Click the *OK* button to apply the changes and close the Operation Parameters dialog box.



## Generating Toolpaths

1. Click the *Generate Toolpath* button on the SOLIDWORKS CAM Command Manager. SOLIDWORKS CAM generates the toolpaths for all operations.
2. Under *Top Part Setup*, hold down the *Shift* key and select the first and last operations in the tree.

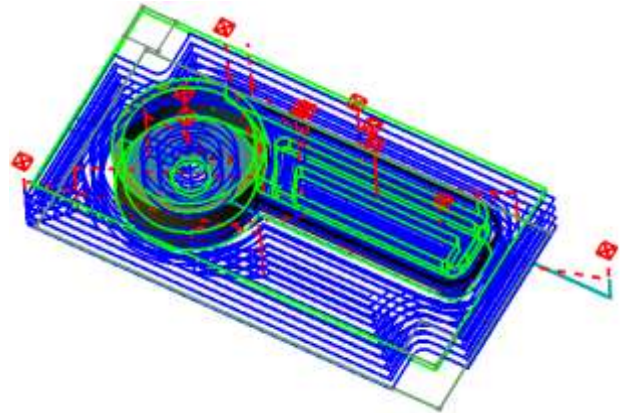
Notice how the toolpath has avoided the clamp areas.



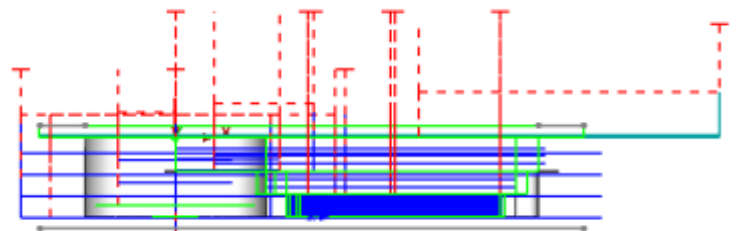

All toolpaths avoid the clamp area

3.  Click on the *View Orientation* icon and change to the *Top view*  and notice that the toolpath has not gone to the bottom of the material because a *Bottom Allowance* of **4.5mm** was set for the Rough and Contour Mill operations of the Part Perimeter feature.



Toolpaths do not go upto the bottom of the material

## Simulating Toolpaths

1. In the Operation tree, right-click on the *Top Part Setup* and select *Simulate Toolpath* from the RMB context menu.
2. Click  *Run* to simulate the tool path. The result should be similar to the example.
3.  Click *Close* to close the simulation and return to the model.

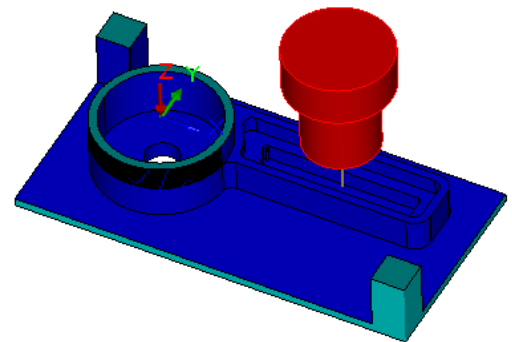

Simulating the Toolpath

## Customizing Toolpaths

In the final part of this tutorial, you will change some of the Mill Part Setup parameters and operation parameters in order to customize the toolpaths.

1.  Onn the SOLIDWORKS CAM Command Manager, click the *SOLIDWORKS CAM Options* button.

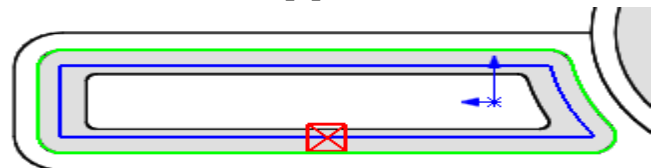

Contour Mill Toolpath

2. The Options dialog box will be displayed. Click the *Update* tab.
3. Set the *Update toolpaths when parameters change* option to *Never*.
4. Click *OK* to apply the changes and close the dialog box.
5. In the Operation tree, double click on the *Contour Mill4* operation under *Top Part Setup* to open its Operation Parameters dialog box. (*Contour Mill4* is the operation for the irregular pocket feature.)
6. Click on the *Leadin* tab.
7. In the *Leadin/out point* group box, leave the option set to *Mid-point*.
8. Change the Leadin Type to *Perpendicular*.
9. Set the Leadin amount to **5mm**.
10. Click *OK* to apply the changes and close the dialog box.
11. Right click on the same *Contour Mill4* operation and select *Generate Toolpath* from the RMB context menu.
12. Highlight *Contour Mill4* operation in the Operation tree. The pierce point displays as a square marker in the middle of the edge because the *Mid-point* option is selected.
13. Rotate the part and notice the Leadin is perpendicular at the mid-point of the edge. Notice the SOLIDWORKS origin. You will use that as the start of the leadin.
14. In the Operation tree, double-click *Contour Mill4* again.
15. In the displayed Operation Parameters dialog box, click the *Leadin* tab and set the Leadin Type to *None*.
16. Click the *Feature Options* tab.
17. For the *Entry Type*, use the default Method of *None*.  
With this option, the end mill feeds down in Z at the specified entry point.
18. In the *Entry points* group box, click in the *Entities selected* box to set the focus.
19. In the graphics area, rotate the part, if necessary, and pick the SOLIDWORKS origin with your mouse.
20. *Point* displays in the *Entities selected* list box and the X,Y coordinates are specified.
21. Click *OK* to apply the changes and close the dialog box.

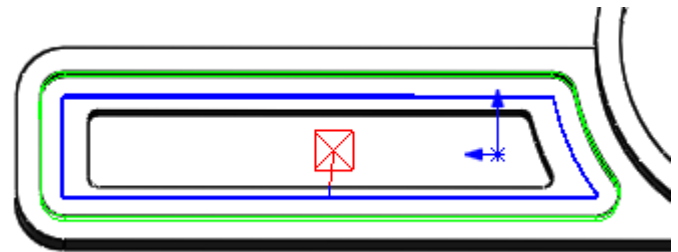

**Pierce point marker at the middle of the edge**



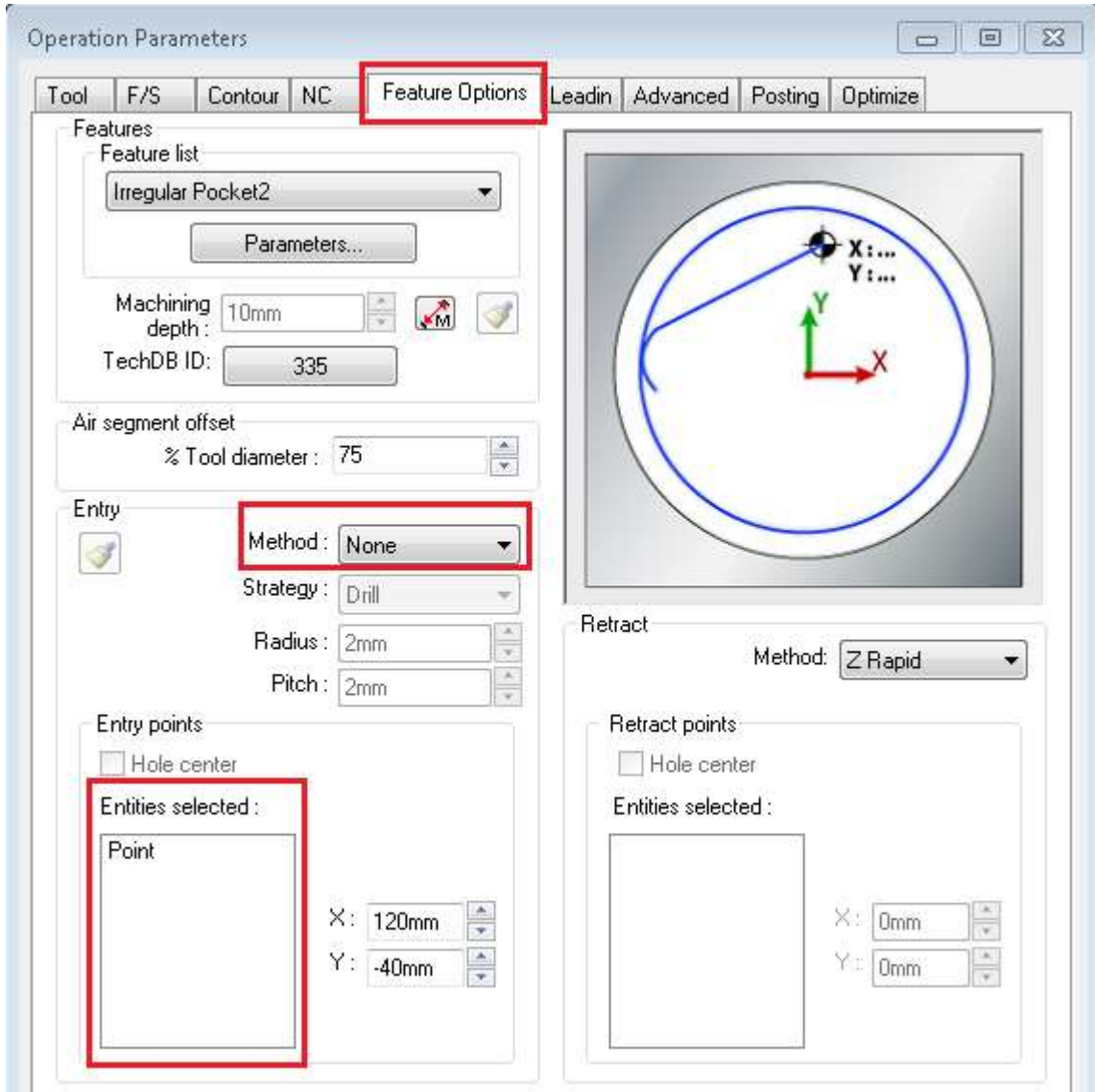

**Feature Options tab in Operation Parameters Dialog Box**

22. Right click on the same *Contour Mill4* operation in the Operation tree and select *Generate Toolpath* on the RMB context menu.

The start of the leadin changes to the origin point that was selected. This acts as a leadin even though the Leadin Type was set to *None*.

23. Right click *Mill Part Setup5* in the tree and select *Post Process* from the RMB context menu.

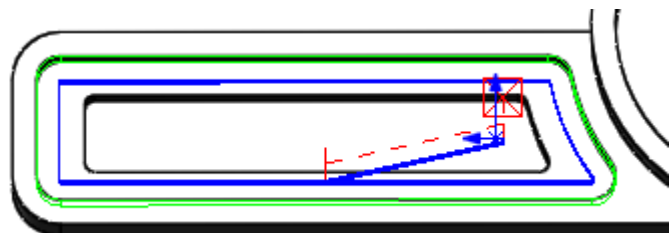

**Leadin is perpendicular at the midpoint of the edge**

24. In the Post Output File dialog box, use either the default file name or type a different name and save the file. Click the *Run* button in the Post Process Output dialog box to output the G-code file. After reviewing the code, click *OK* to close the dialog box.