

ΠΑΝΕΠΙΣΤΗΜΙΟ ΔΥΤΙΚΗΣ ΜΑΚΕΔΟΝΙΑΣ
ΤΜΗΜΑ ΕΙΚΑΣΤΙΚΩΝ ΚΑΙ
ΕΦΑΡΜΟΣΜΕΝΩΝ ΤΕΧΝΩΝ

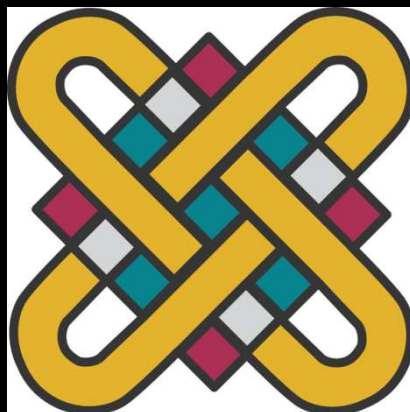

1^ο Εργαστήριο Ζωγραφικής
Κύκλος

Το Χρώμα

Γιάννης Ζιώγας
Αναπληρωτής Καθηγητής

Ισορροπία

ΙΣΟΡΡΟΠΙΑ



ΣΥΜΜΕΤΡΙΑ

*Στατική
ισορροπία*

ΑΣΥΜΜΕΤΡΙΑ

*Δυναμική
ισορροπία*

ΙΣΟΡΡΟΠΙΑ

Η ισότητα μεταξύ έλξεως και αντιστάσεως

(Της γής αυτής την ισορροπίαν - ισορροπία έλξεως και αντιστάσεως. Πλάτ. Φαίδ. 109A)

ΙΣΟΡΡΟΠΙΑ

Συμμετρία

Η ιδιότης του σύμμετρου ή συμμετρικού, αρμονία λόγω κανονικών αναλογιών, που αποτελεί ένα από τους χαρακτήρες του καλού και αγαθού.

(Βίου συμμετρίη, η νυκτός προς ημέρα συμμετρία)

Ασυμμετρία

Η έλλειψις συμμετρίας, αναλογίας, αρμονίας, η δυσαναλογία
(ασυμμετρίας και αισχροτήτας γέμουσαν ψυχήν)

Handwritten text in Italian, likely a preface or introduction to the drawing, discussing the proportions of the human body.

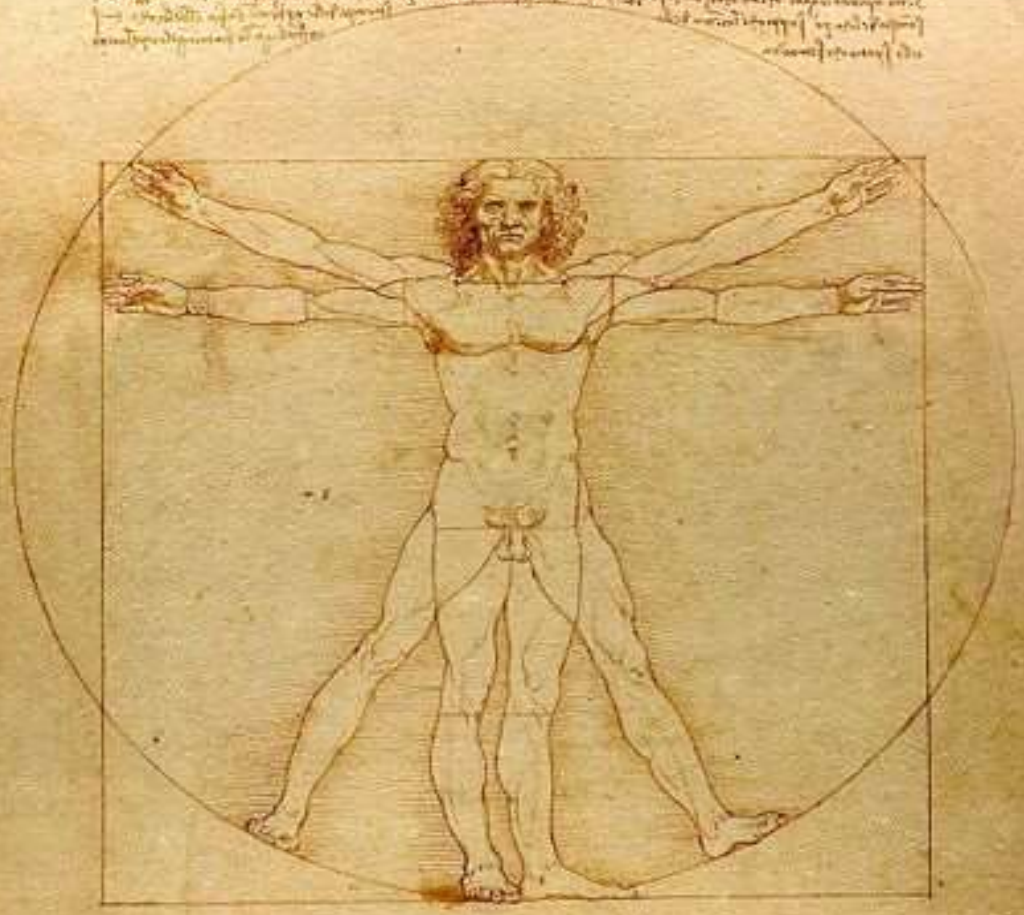

Handwritten text in Italian, likely a continuation of the preface or a detailed explanation of the drawing's proportions.

Small handwritten signature or mark at the bottom right corner.



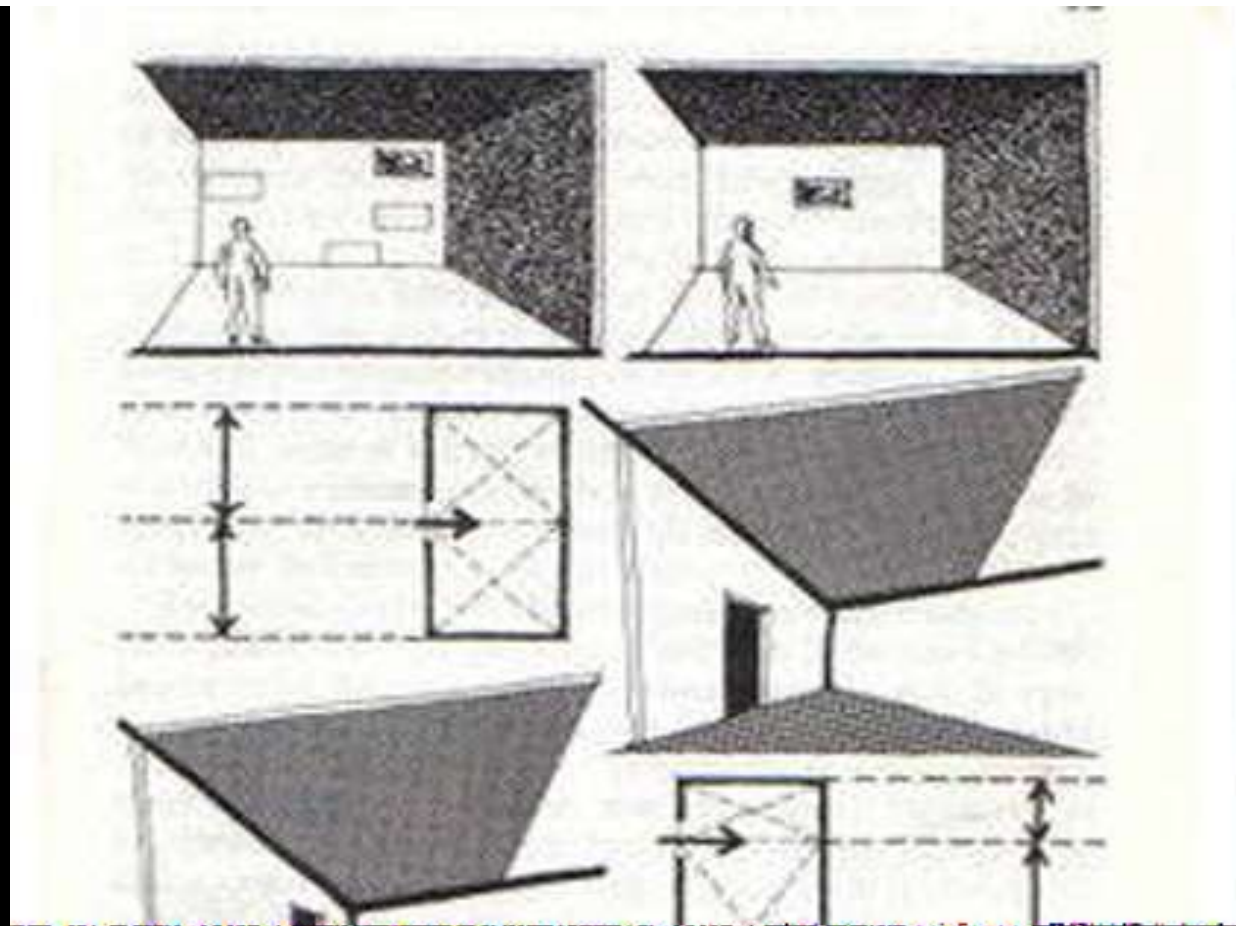

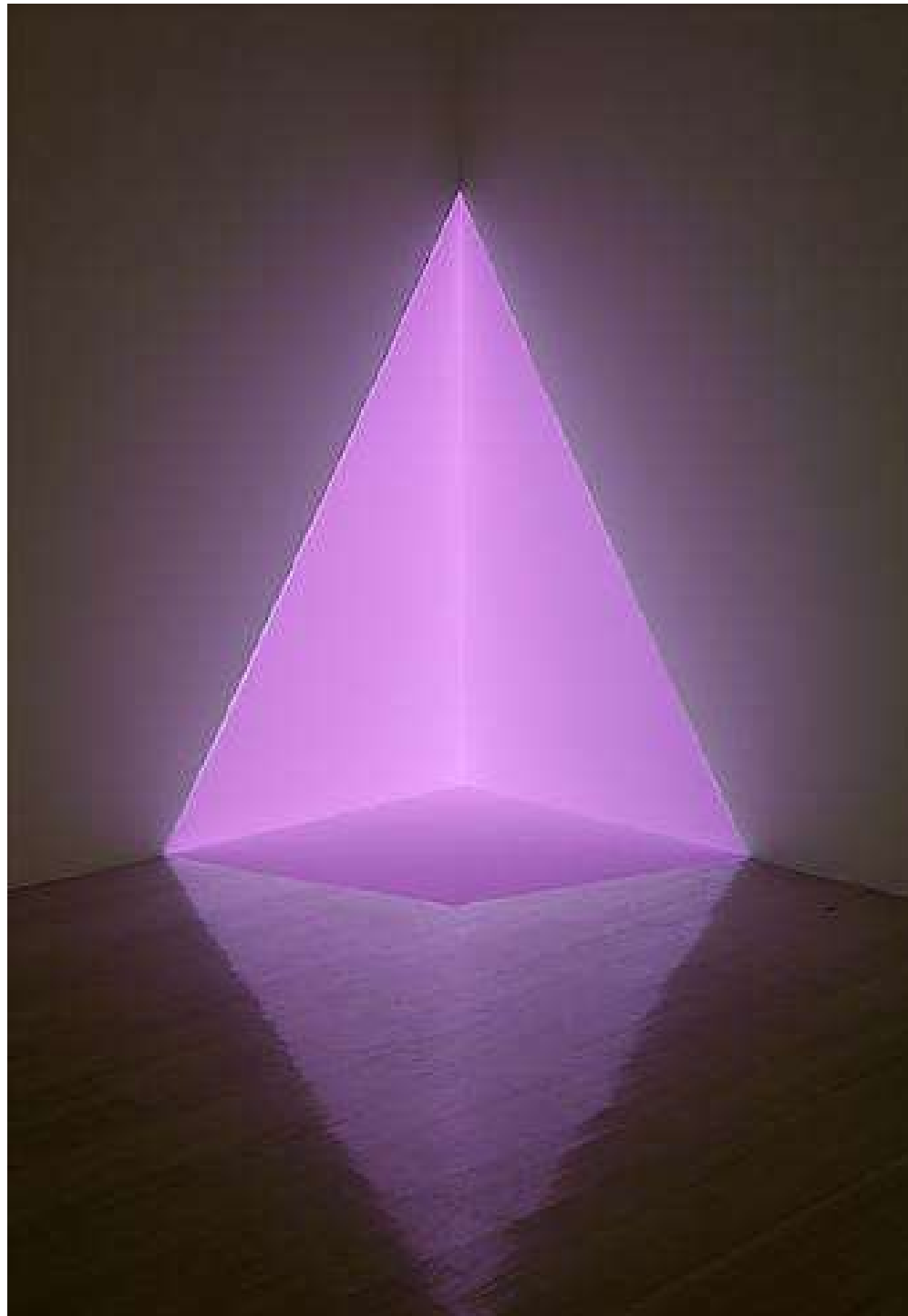



See note

Common

+

Common



23

Non-symmetrical balance.

(Symbol):

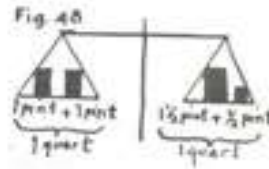

Disturbed
Balance

Restored
Balance

a) Metric:

b) Weight:

c) Character:

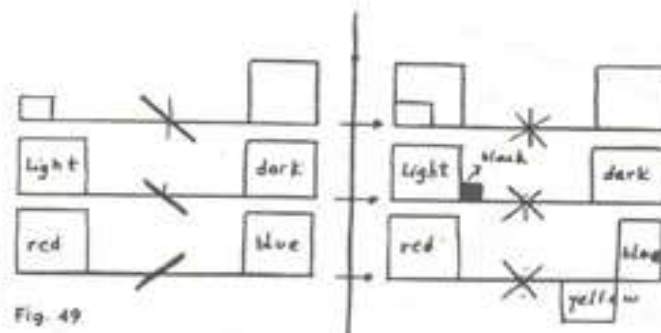

Fig. 49

ΜΕΡΙΚΕΣ ΑΝΤΙΘΕΤΙΚΕΣ ΣΧΕΣΕΙΣ

Φως
Άδειο
Πλακάτο
Τριδιάστατο
Διδιάστατο
Γραμμικό
Αφαιρετικό
Στατικό
Συμμετρικό
Καθαρό χρώμα

Σκιά
Γεμάτο
Χειρονομακό
Διδιάστατο
Γραμμικό
Τρισδιάστατο
Περιγραφικό
Ενεργητικό
Ασύμμετρο
Εξουδετερωμένο χρώμα



Will Alshop, Ontario Art School, 2004

ΣΥΜΜΕΤΡΙΑ	ΑΣΥΜΜΕΤΡΙΑ
<p>Η ισορροπία των ίσων</p> <p>Στατικότητα</p> <p>Το κενό συνοδεύει</p> <p>Οι κάθετοι άξονες στηρίζουν</p> <p>Οι τονικότητες και τα χρώματα απλώνονται παντού ισοδύναμα</p> <p>Κυκλαδικός πολιτισμός, Κλασικισμός, Αναγέννηση (Ιταλική και Φλαμανδική), Νεοκλασικισμός, Μινιμαλιστική Τέχνη</p> <p>Φειδίας, Ουτσέλλο, Τιτσιάνο, Πουσέν, Ενγκρ, Σερά, Σεζάν, Τζάντ, Μόραλης, Μοντριάν, Αγκνες Μάρτιν</p>	<p>Η εξουδετέρωση των αντιθέτων</p> <p>Κινητικότητα</p> <p>Το κενό ενεργοποιείται</p> <p>Οι διαγώνιοι άξονες πιέζουν</p> <p>Οι τονικότητες και τα χρώματα περικλείονται σε συγκεκριμένες περιοχές</p> <p>Ελληνιστική περίοδος, , Μπαρόκ, Ρομαντισμός, Φωβισμός, Εξπρεσιονισμός</p> <p>Σκόπας, Μιχαήλ Άγγελος, Καραβάτζιο, Ντελακρουά, Βαν Γκόγκ, Μπουζιάνης, Σήλε, Άουερπαχ,</p>

Χρυσή Τομή

**Η χρυσή τομή είναι ο μέσος χώρος
μεταξύ συμμετρίας και
ασυμμετρίας**

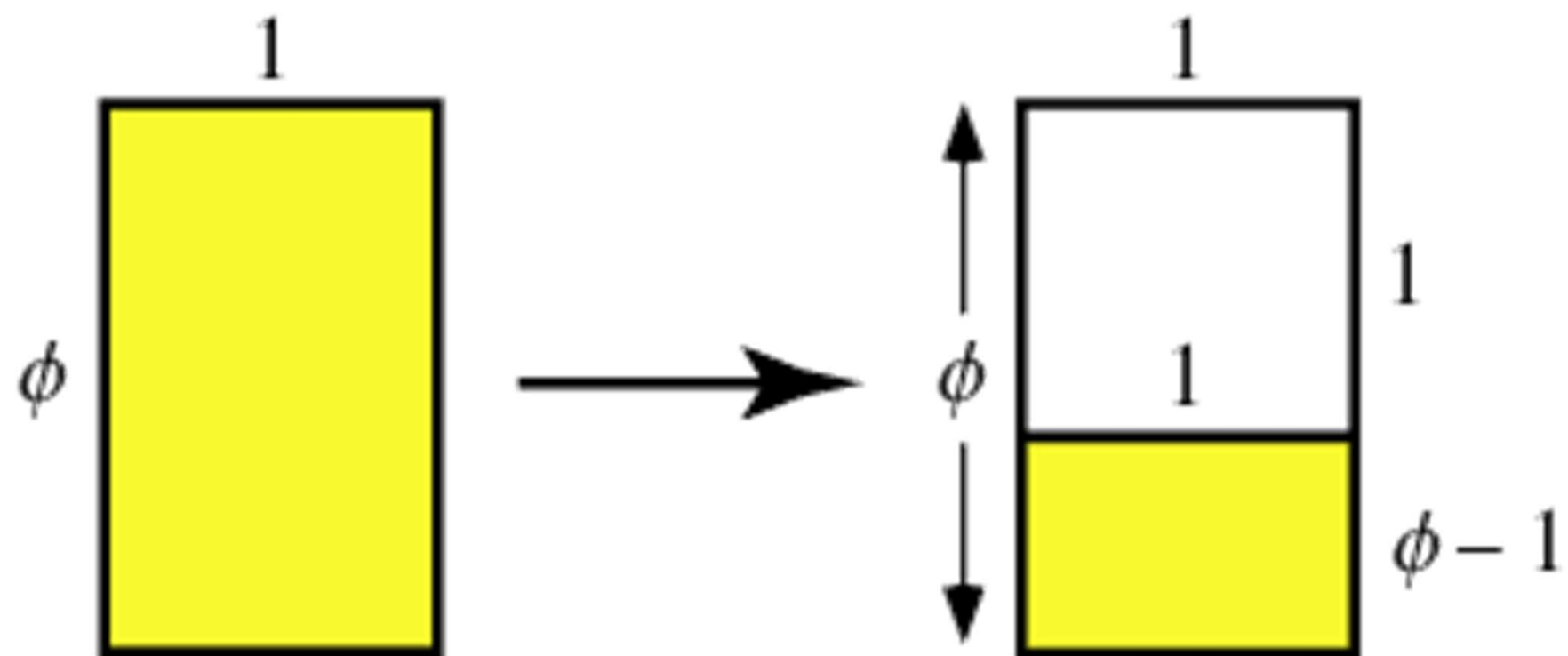

$$\phi = \frac{AC}{CB} = \frac{AB}{AC}$$

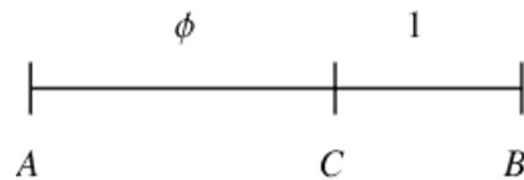

1.618033988749894848204586834365638117720 ...

$$\frac{1}{2} \left(1 + \sqrt{5} \right)$$

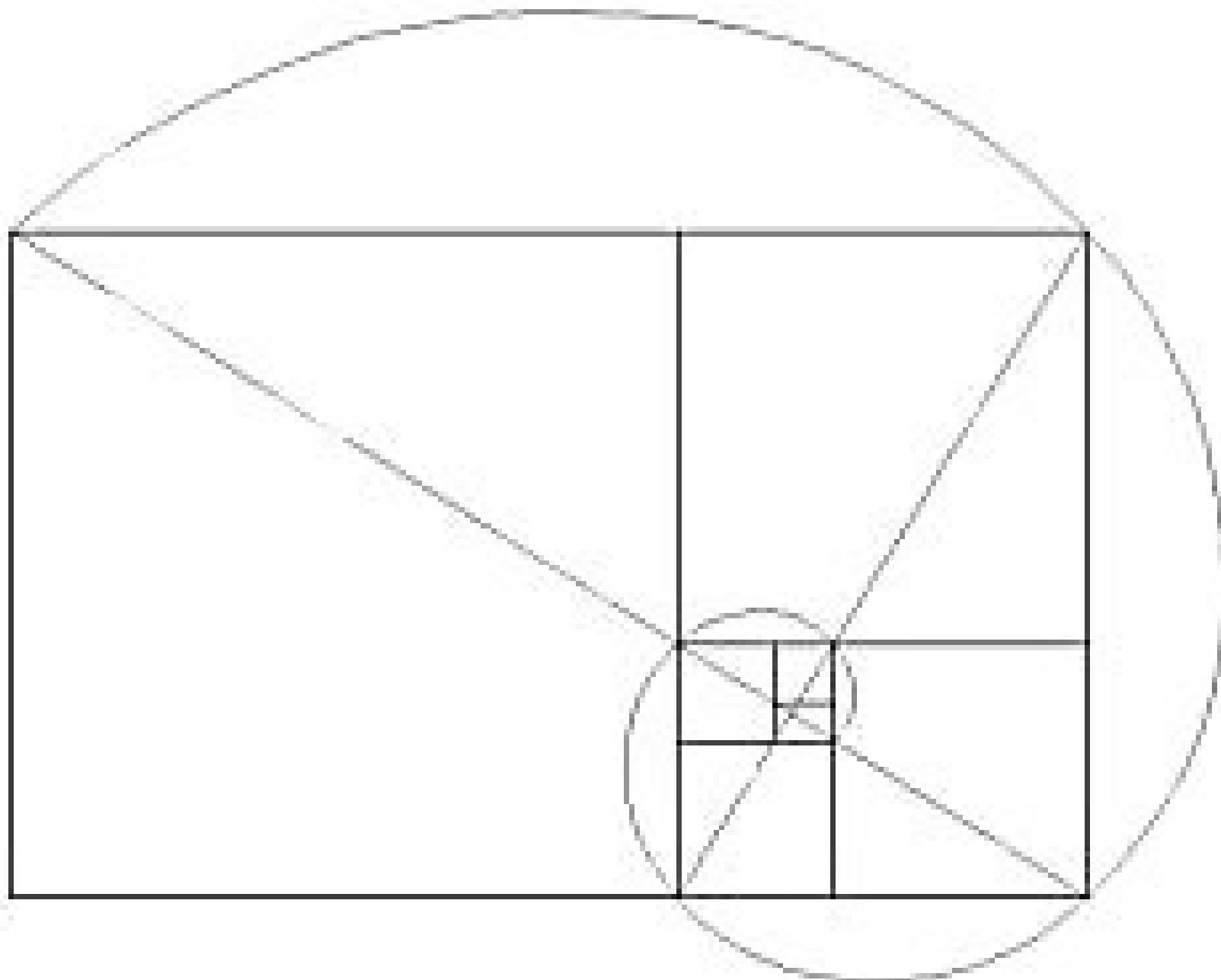

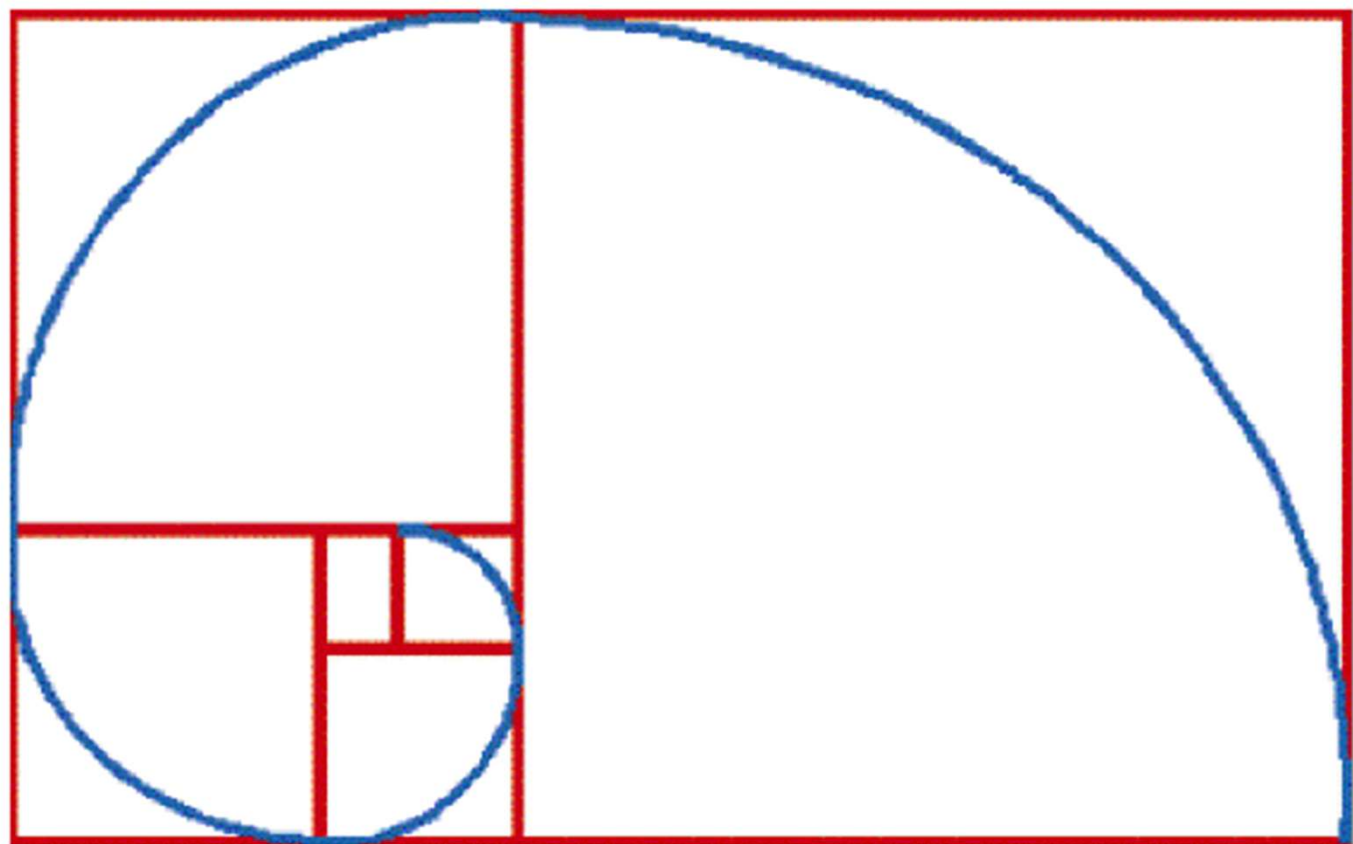

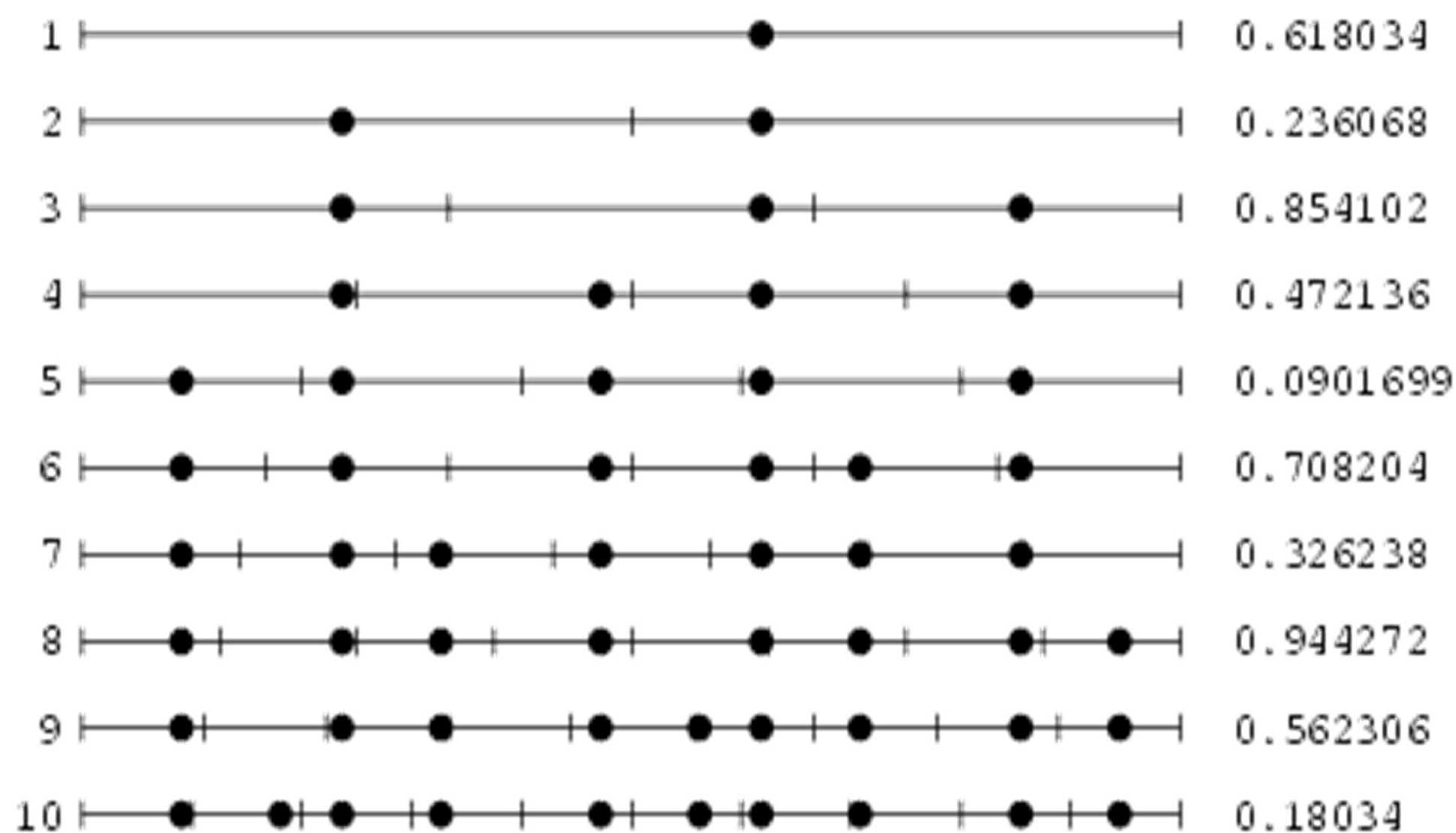

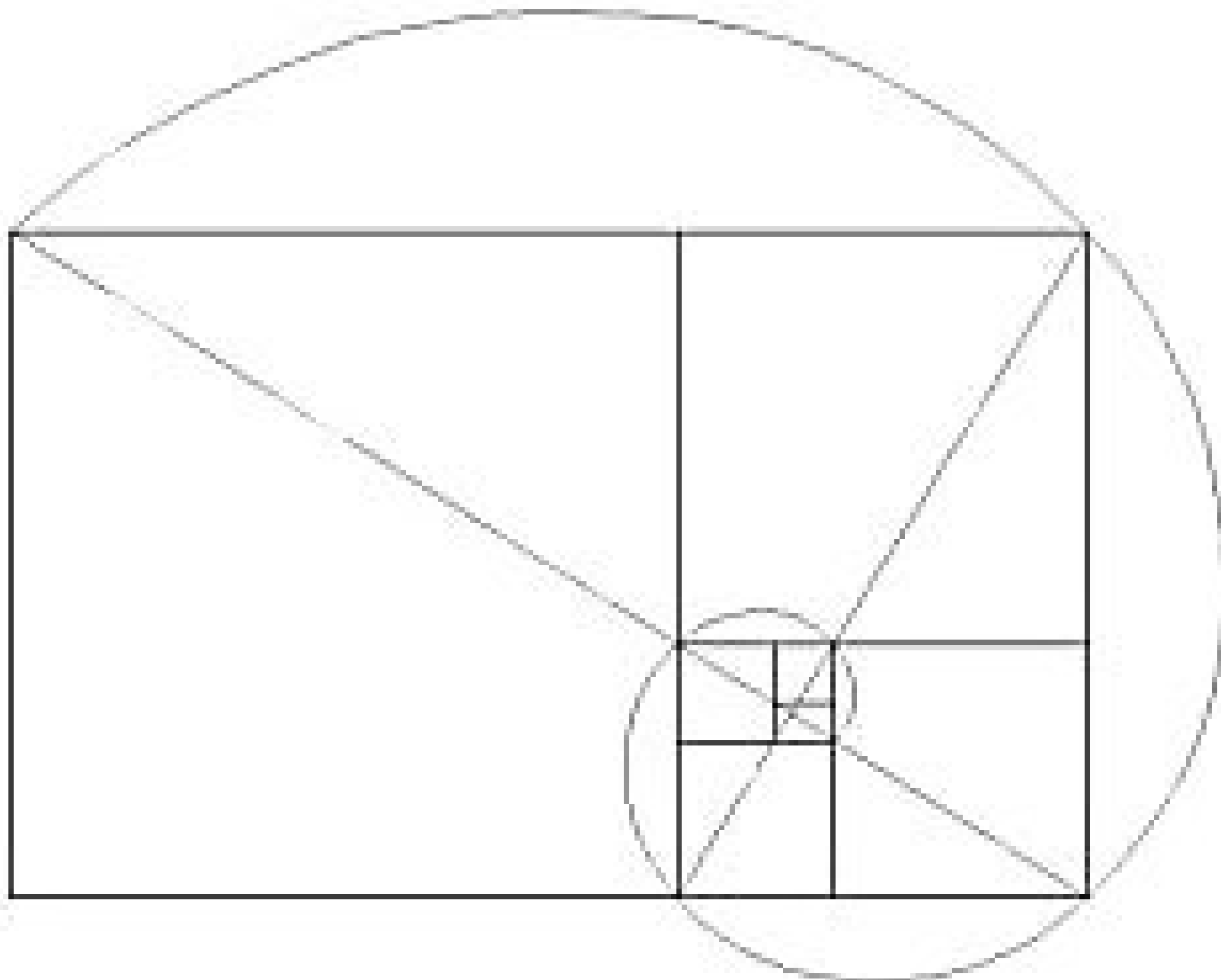

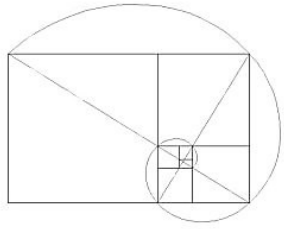

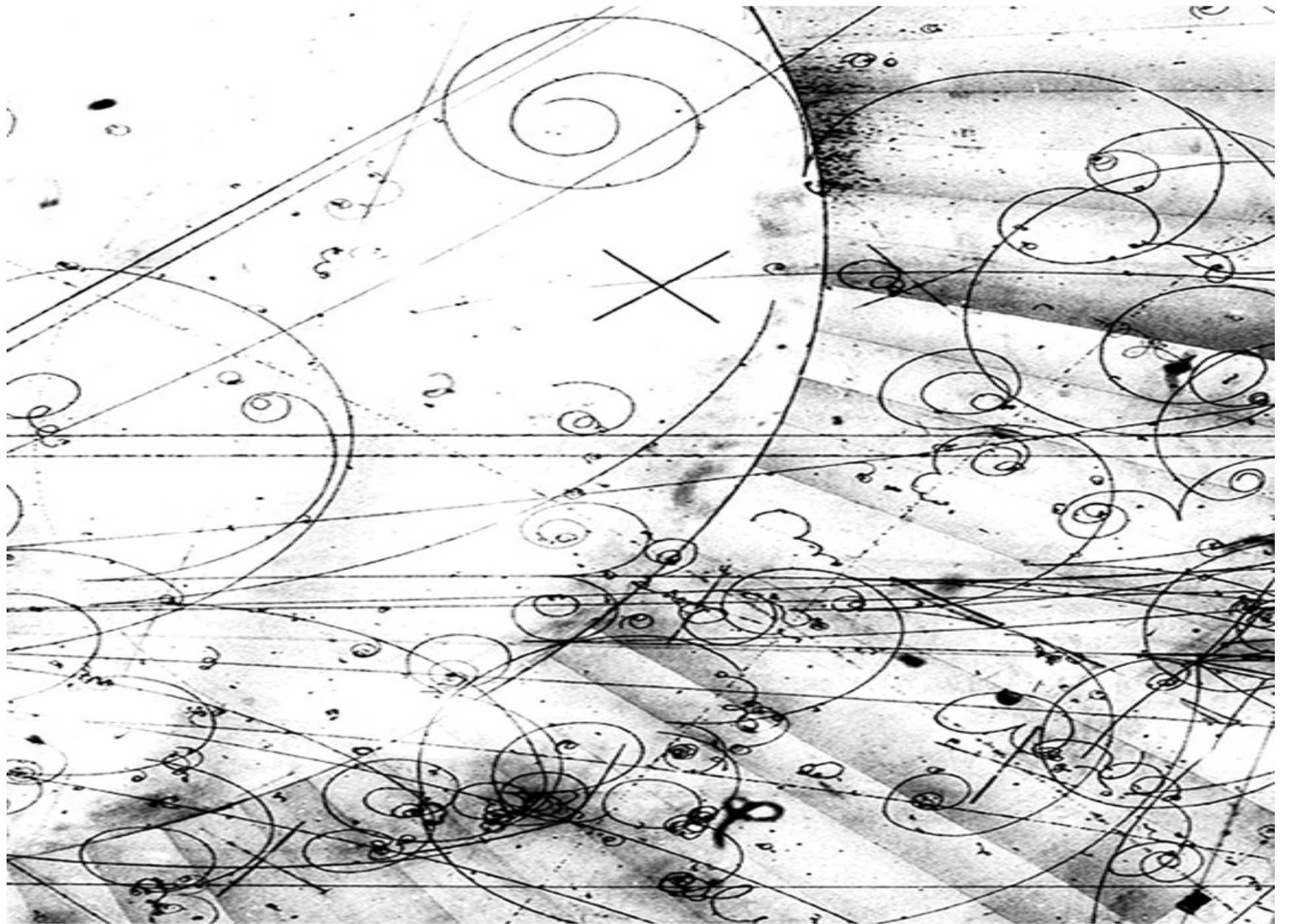



My new Hypothesis: If we're built from Spirals while living in a giant Spiral, then is it possible that everything we put our hands to is infused with the Spiral?"

-- Max Cohen in the motion picture π

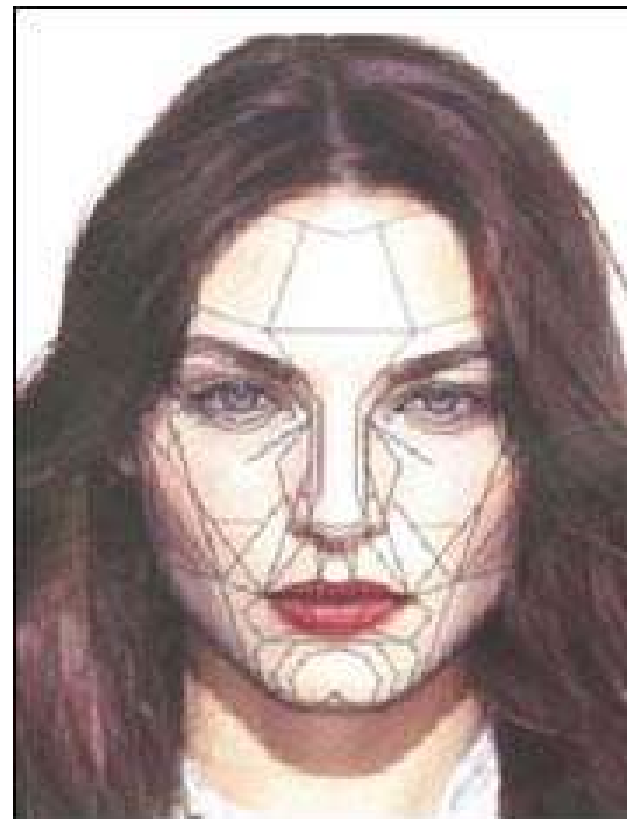
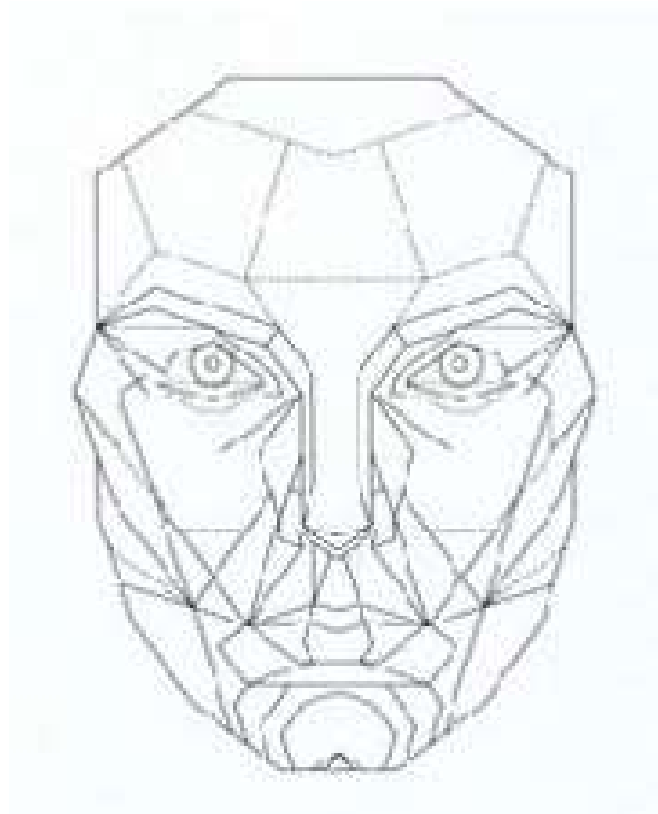

Χρυσή Τομή

**Η χρυσή τομή είναι ο μέσος χώρος μεταξύ
συμμετρίας και ασυμμετρίας**

ΙΣΟΡΡΟΠΙΑ



ΣΥΜΜΕΤΡΙΑ

*Στατική
ισορροπία*

ΑΣΥΜΜΕΤΡΙΑ

*Δυναμική
ισορροπία*



boteh

an asymmetrical
motif

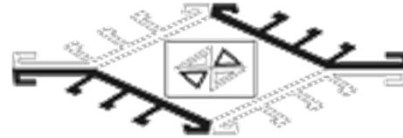

dyrnak gul

a symmetrical
motif







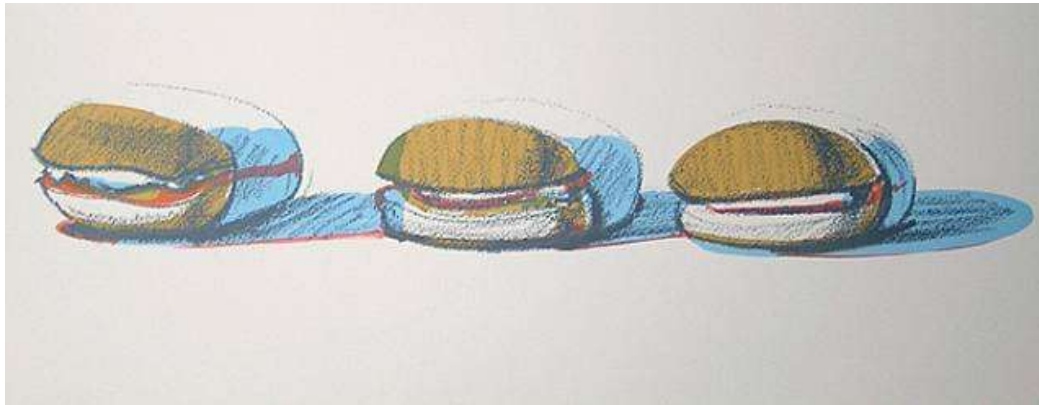
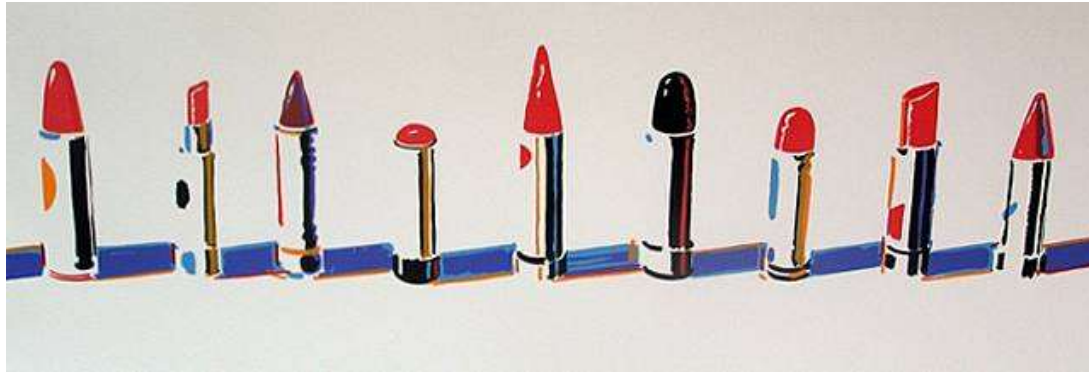



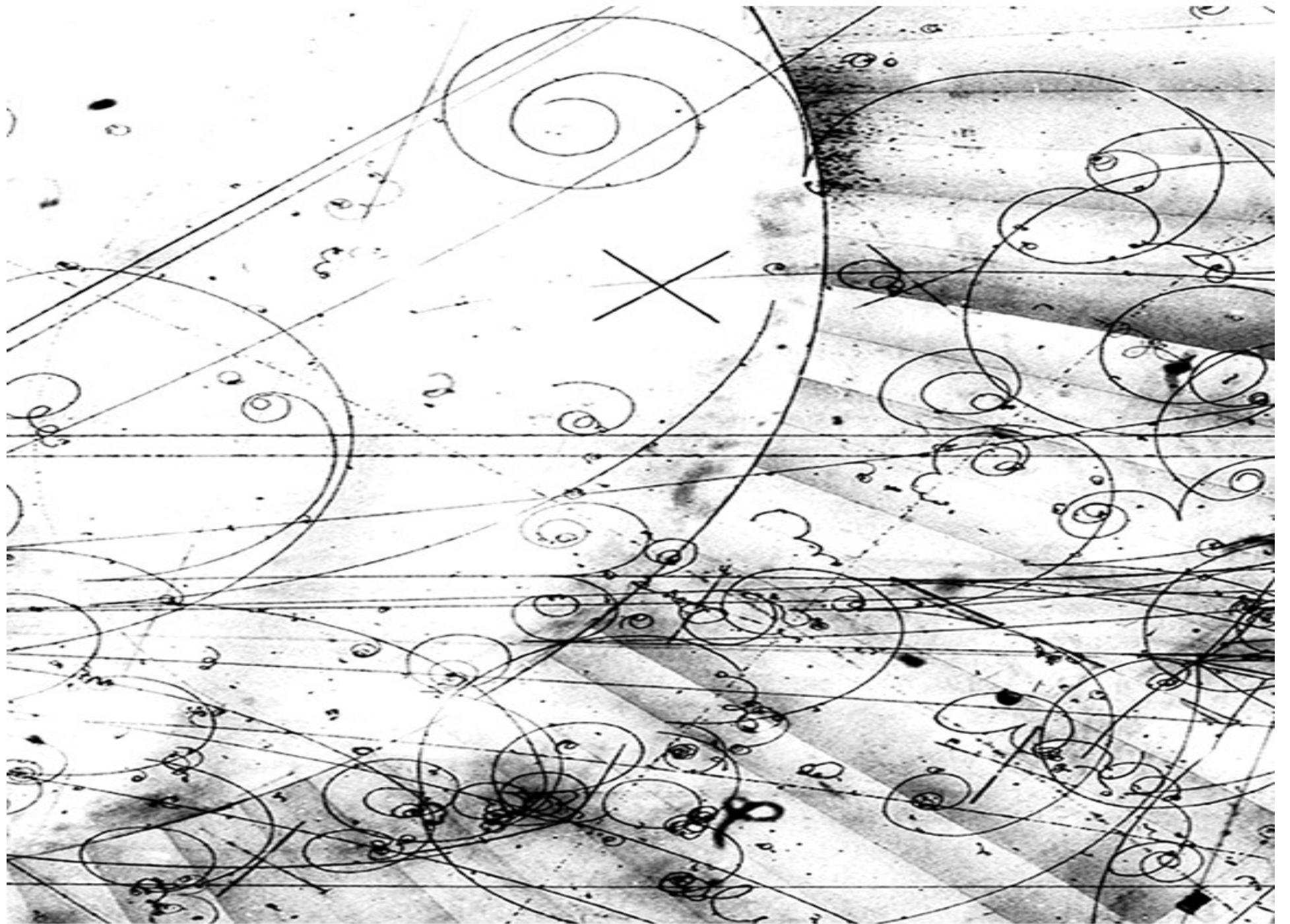

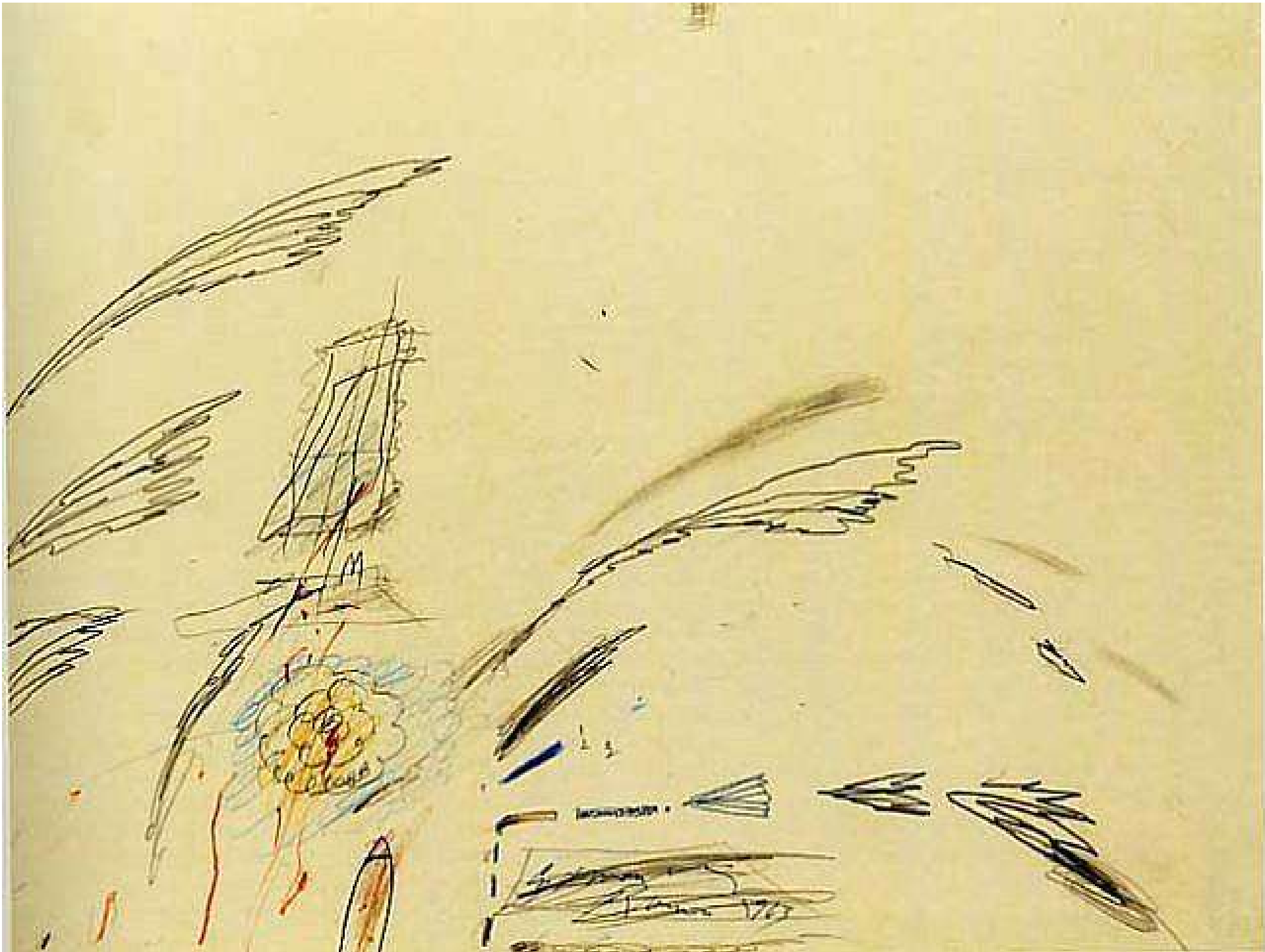

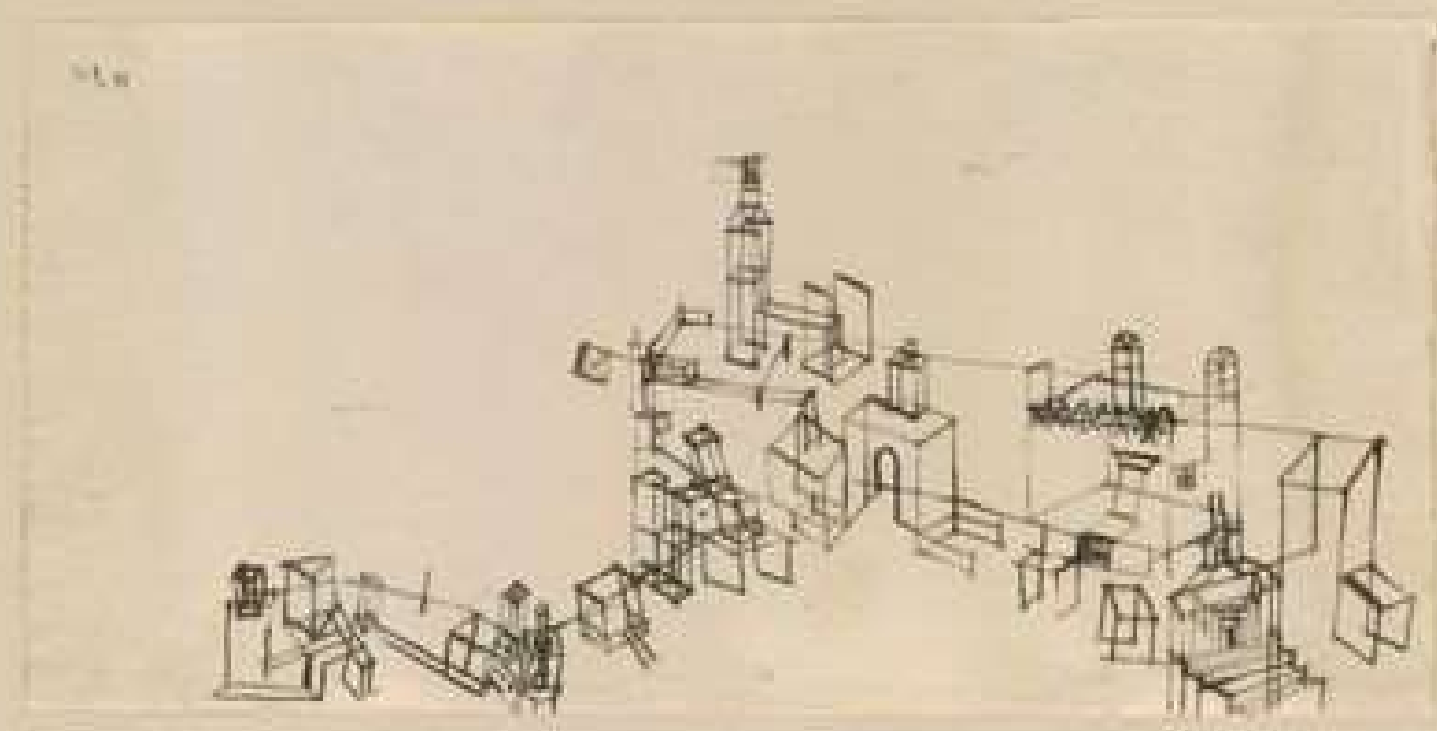

1/10

Architectural drawing

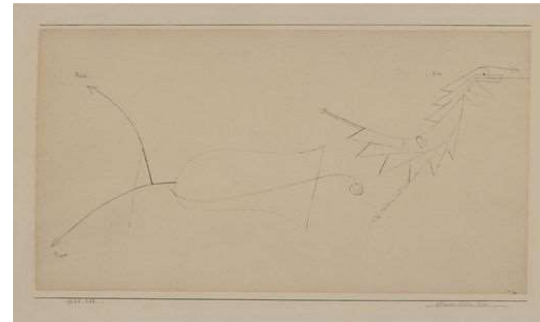
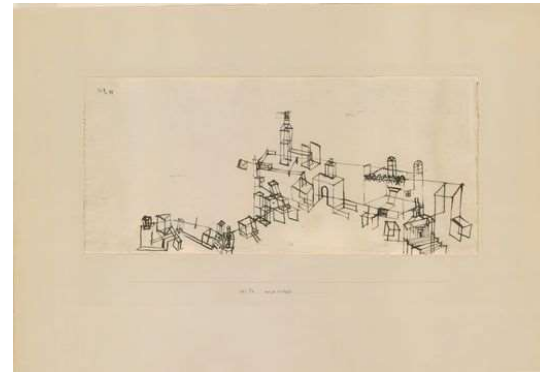
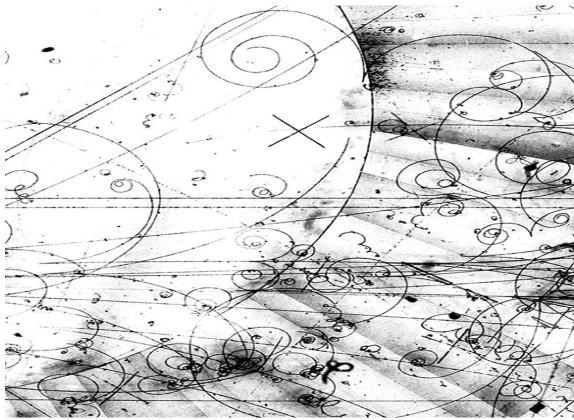

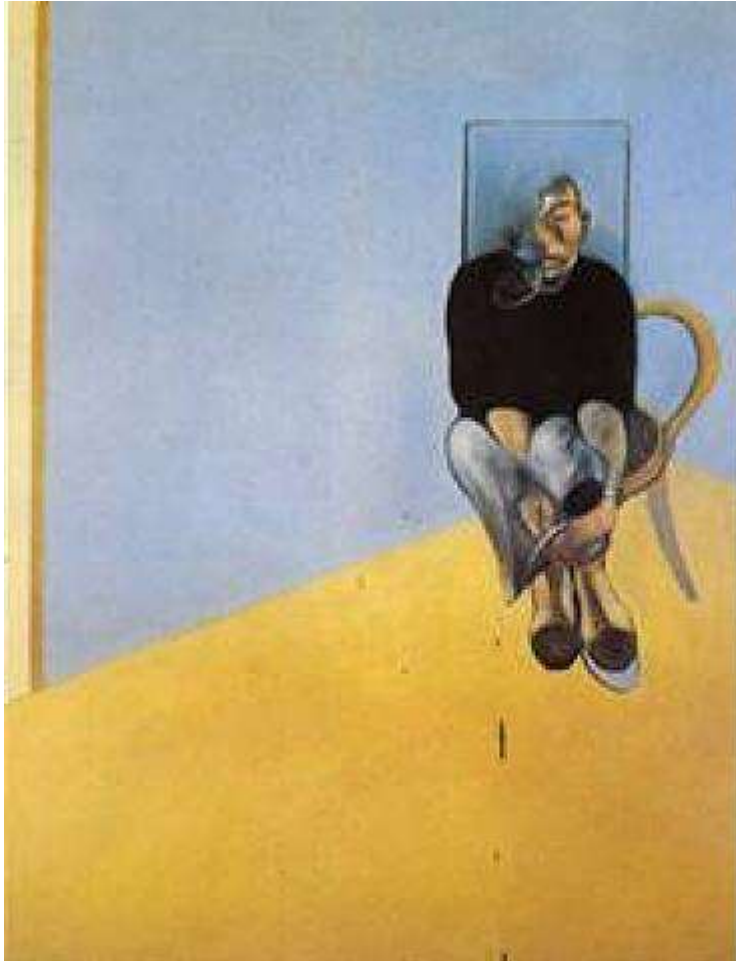

Στατική Ισορροπία

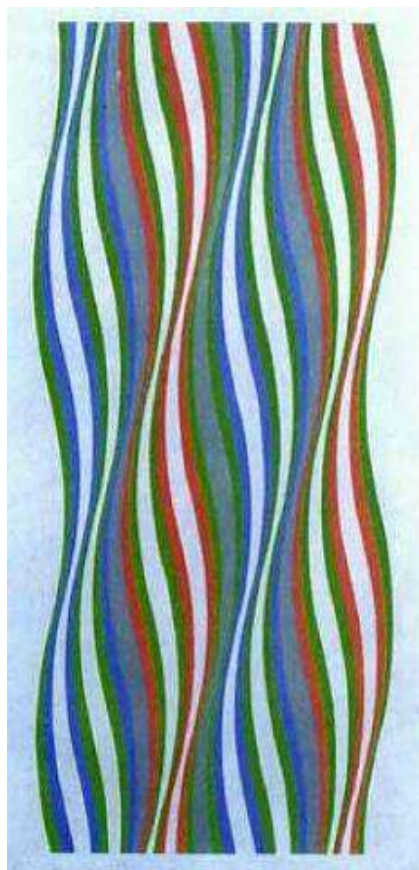



Οπτική Συμμετρία

VS

Γεωμετρική Συμμετρία







Δυναμική Ισορροπία



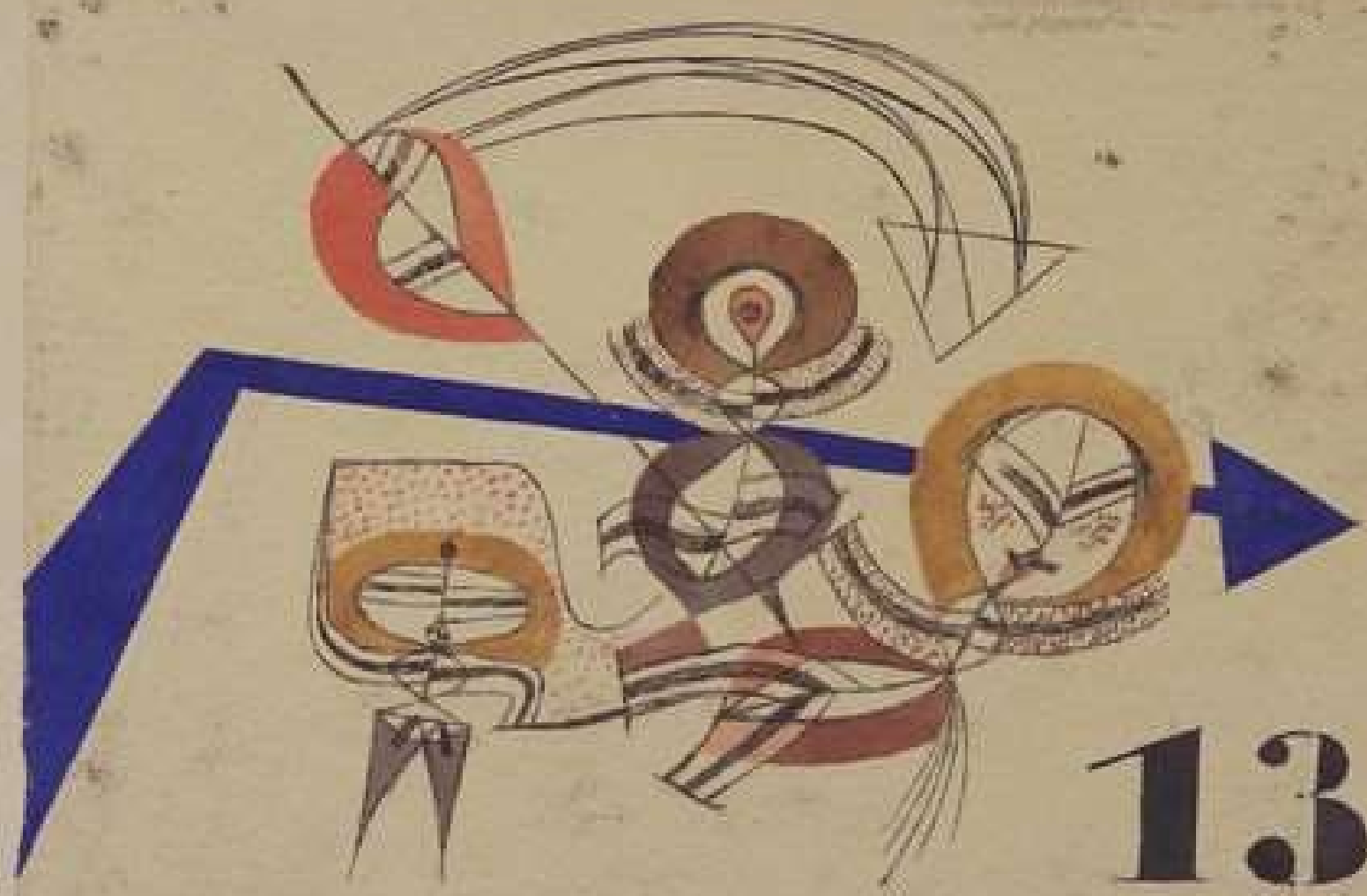

1923/24 Das Leben im Spiegel

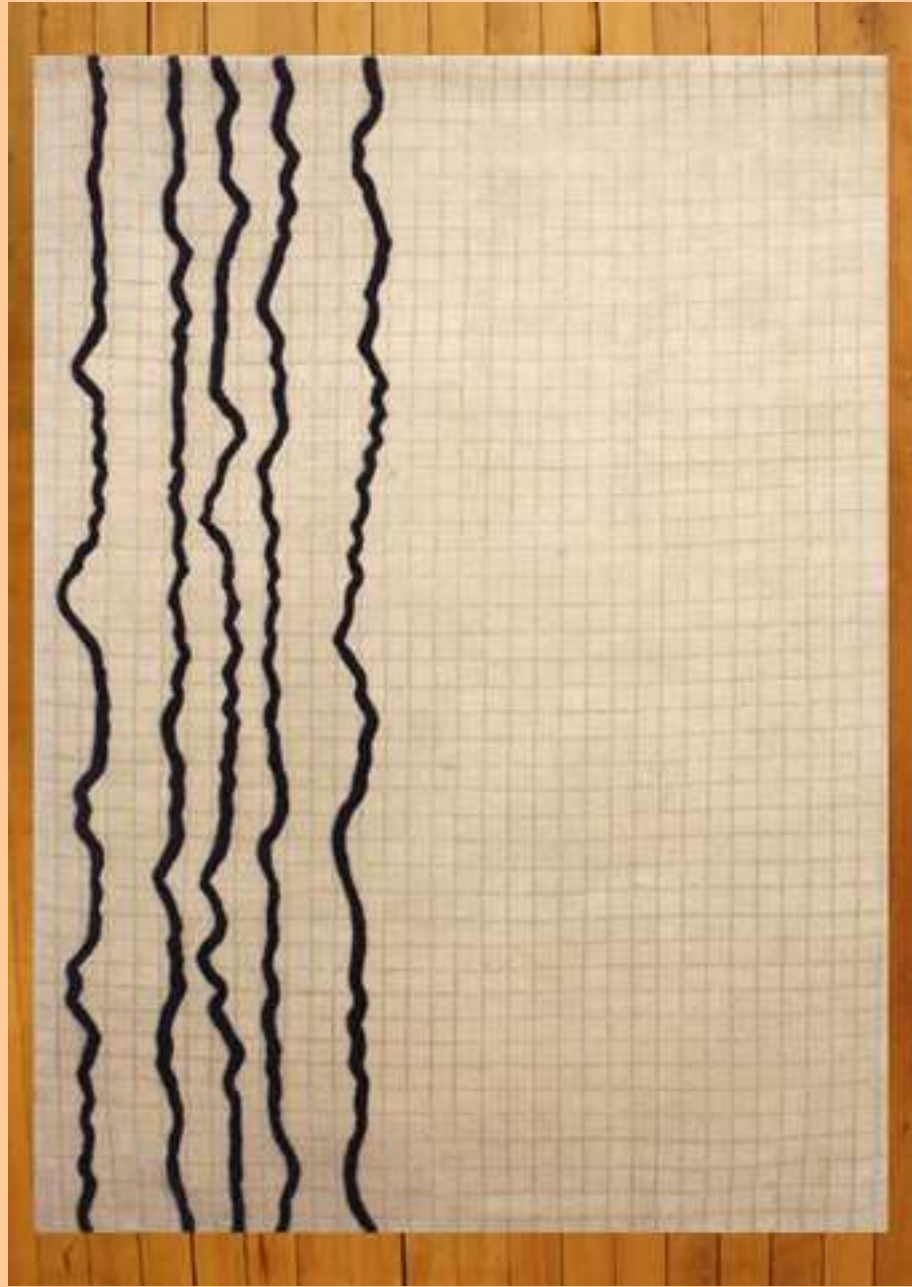

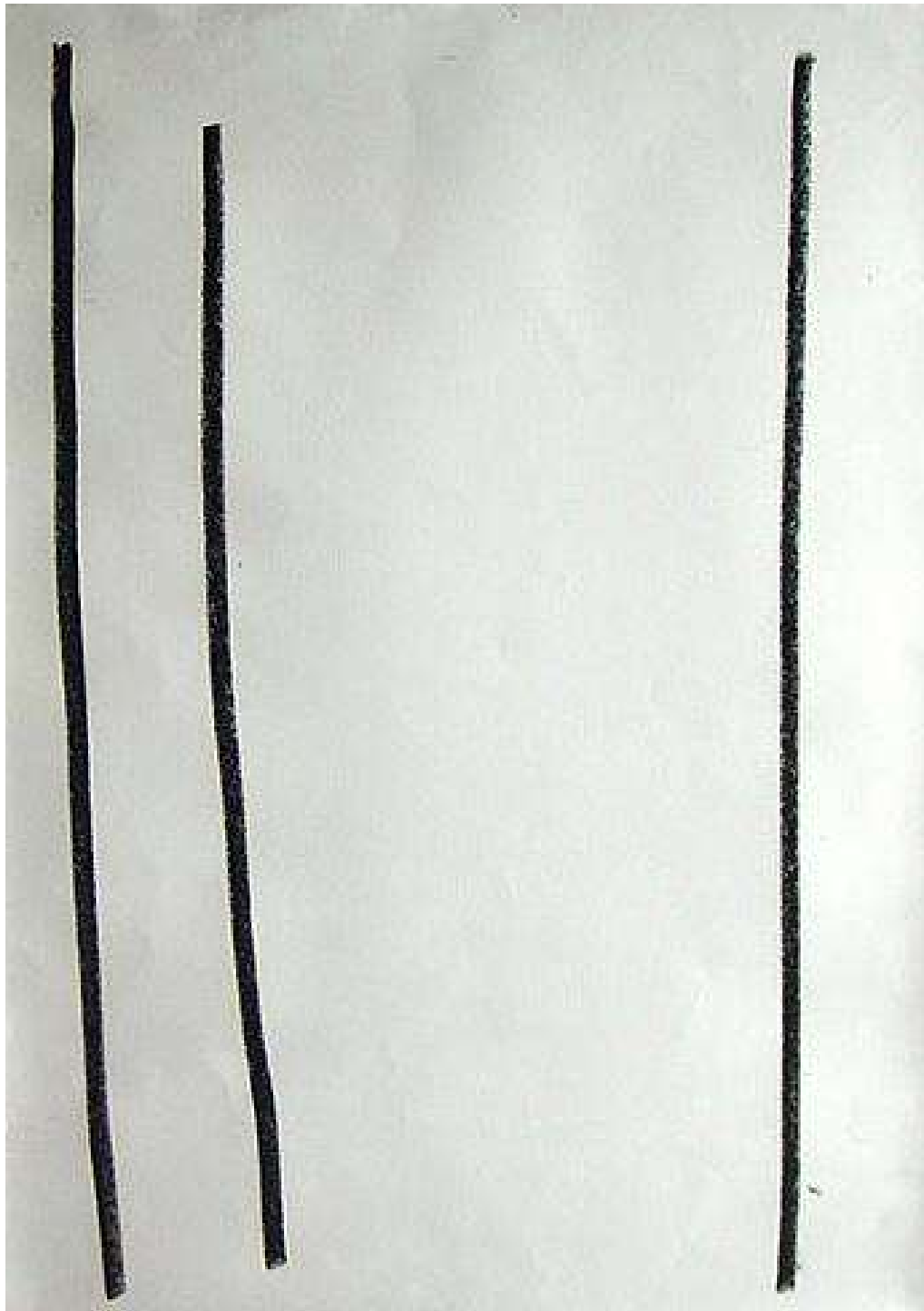

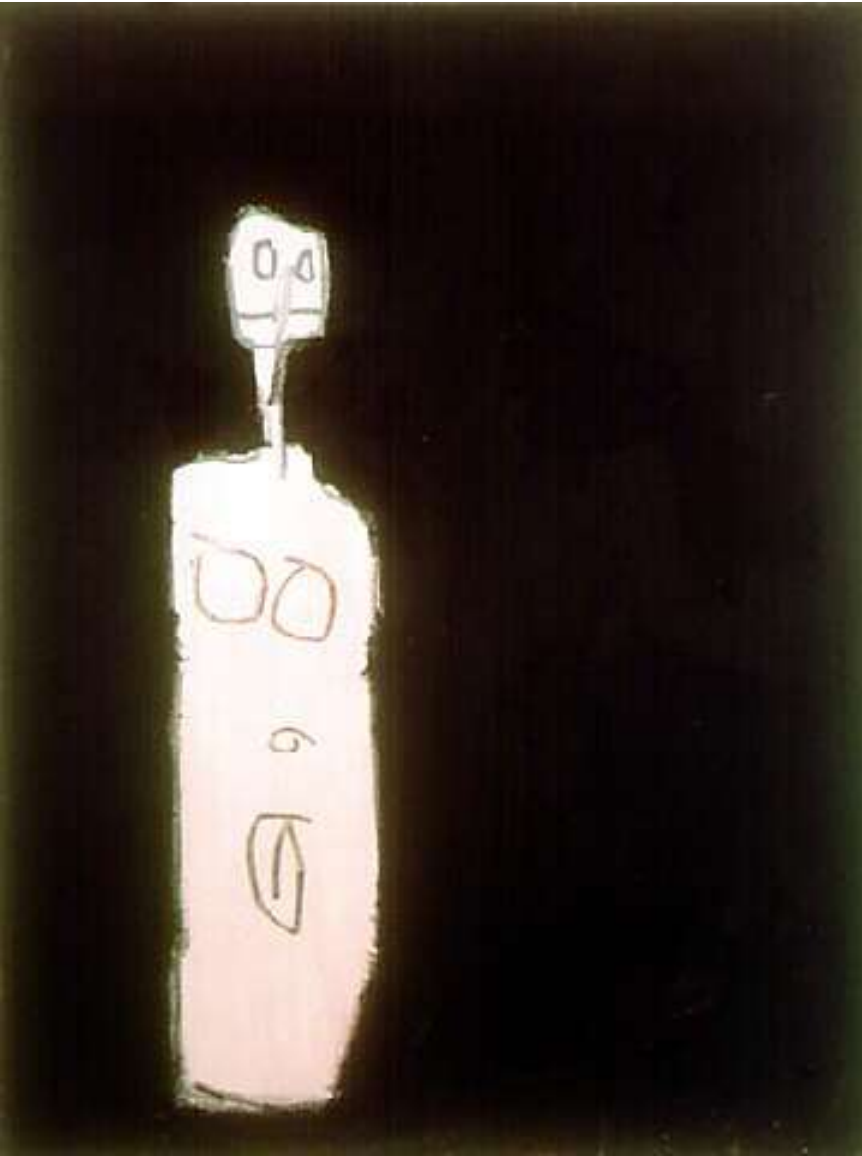

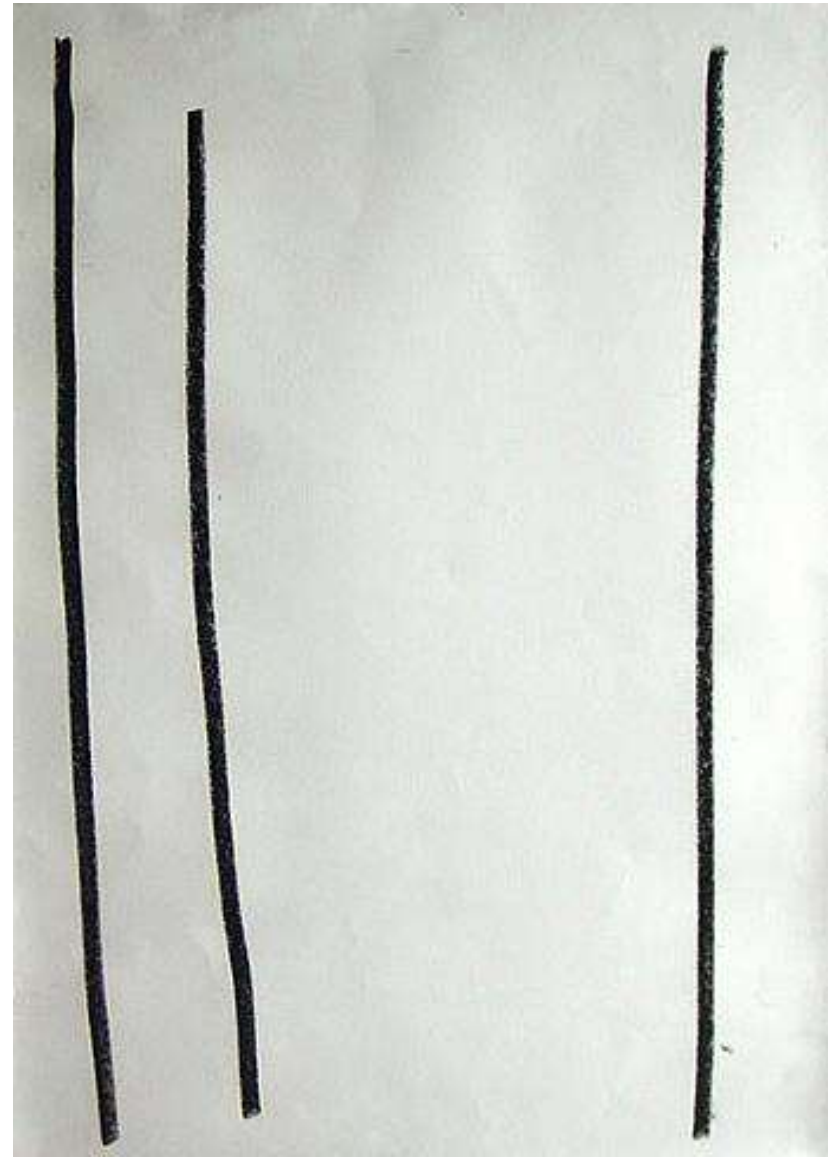
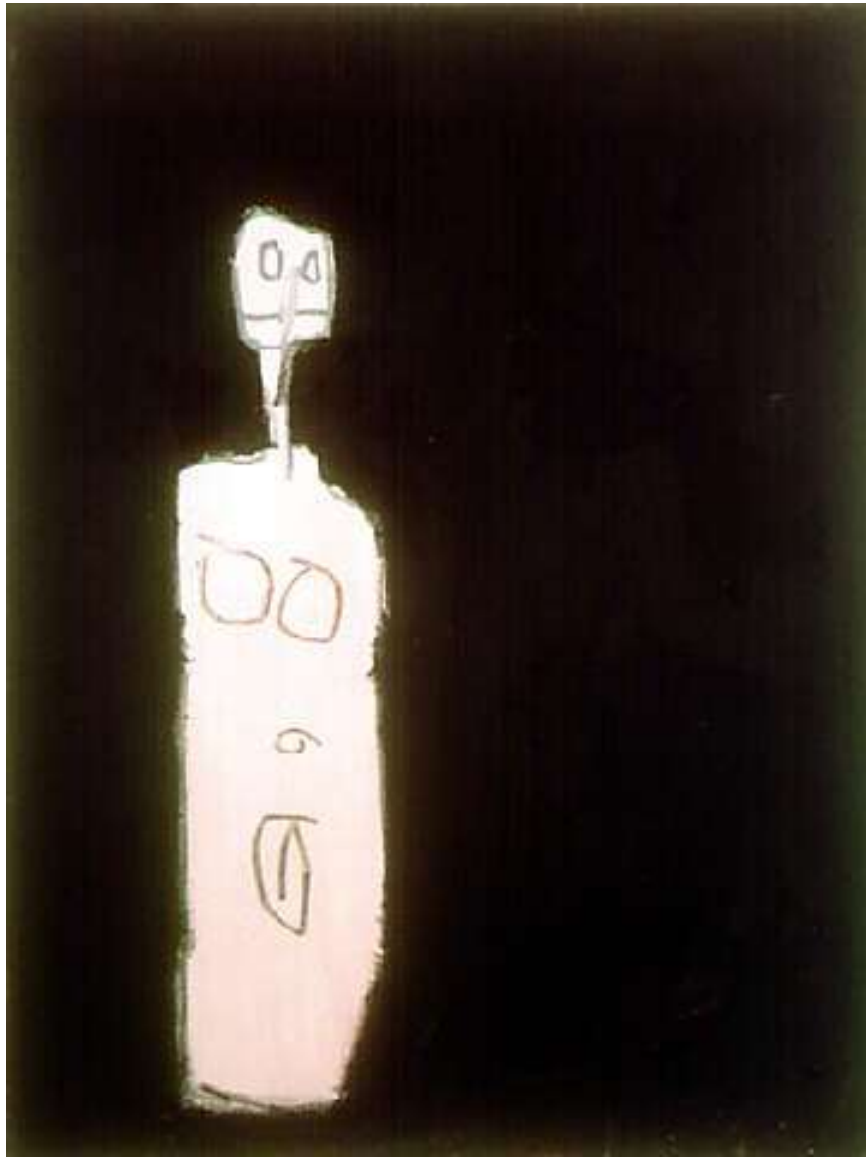

<http://gwydir.demon.co.uk/jo/symmetry/index.htm>

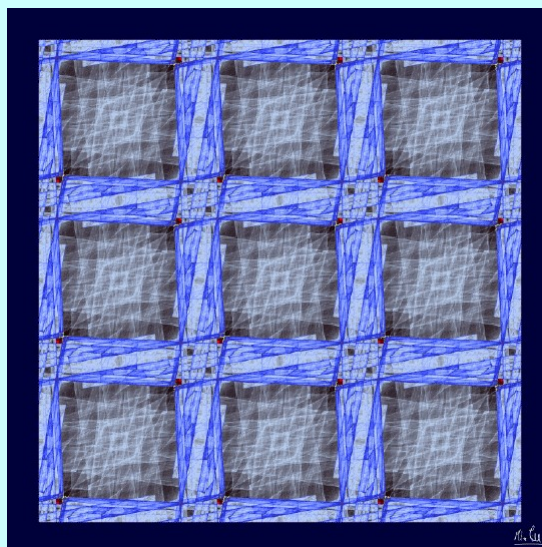
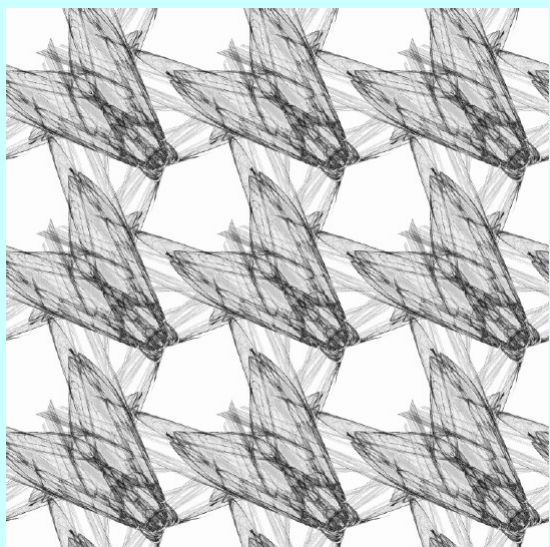

<http://nothung.math.uh.edu/~mike/ag/icons/thorns.jpg>



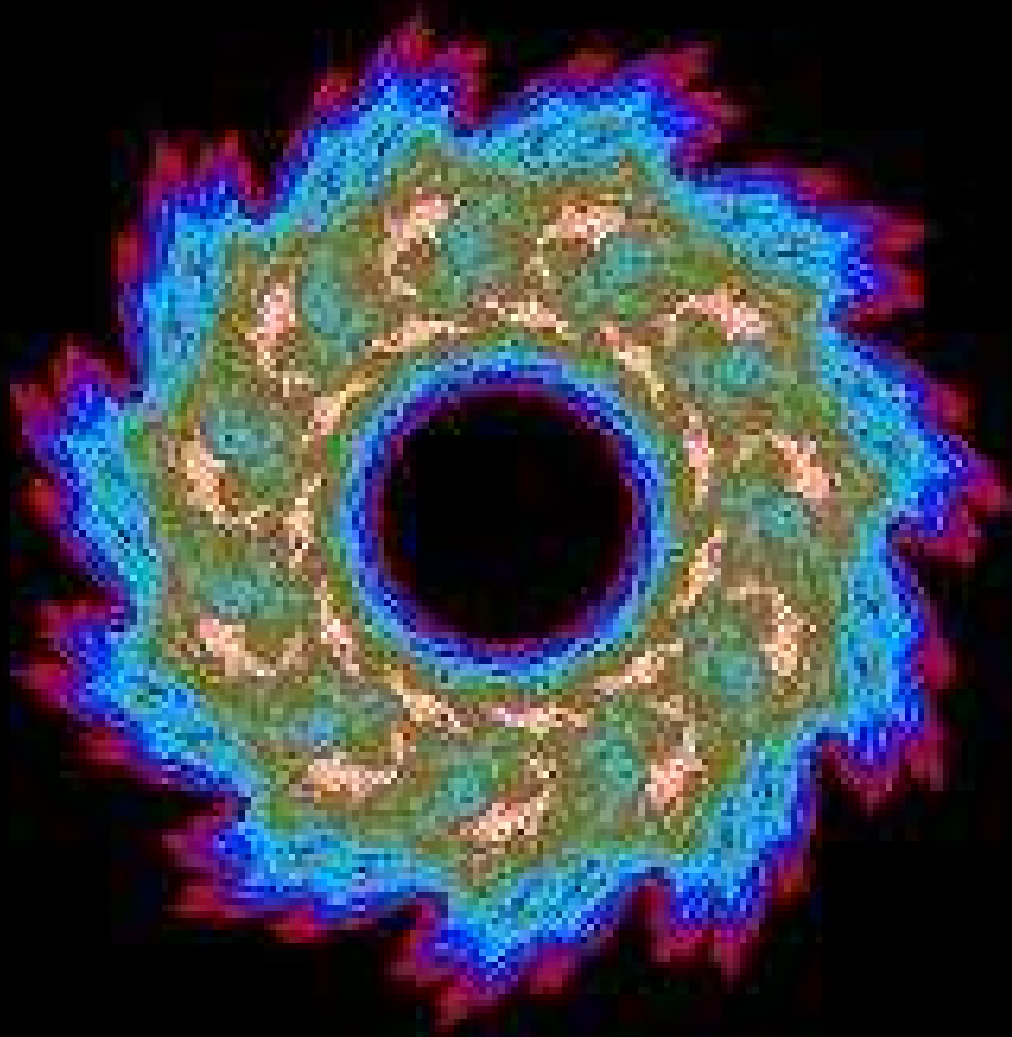

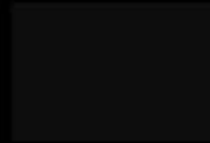
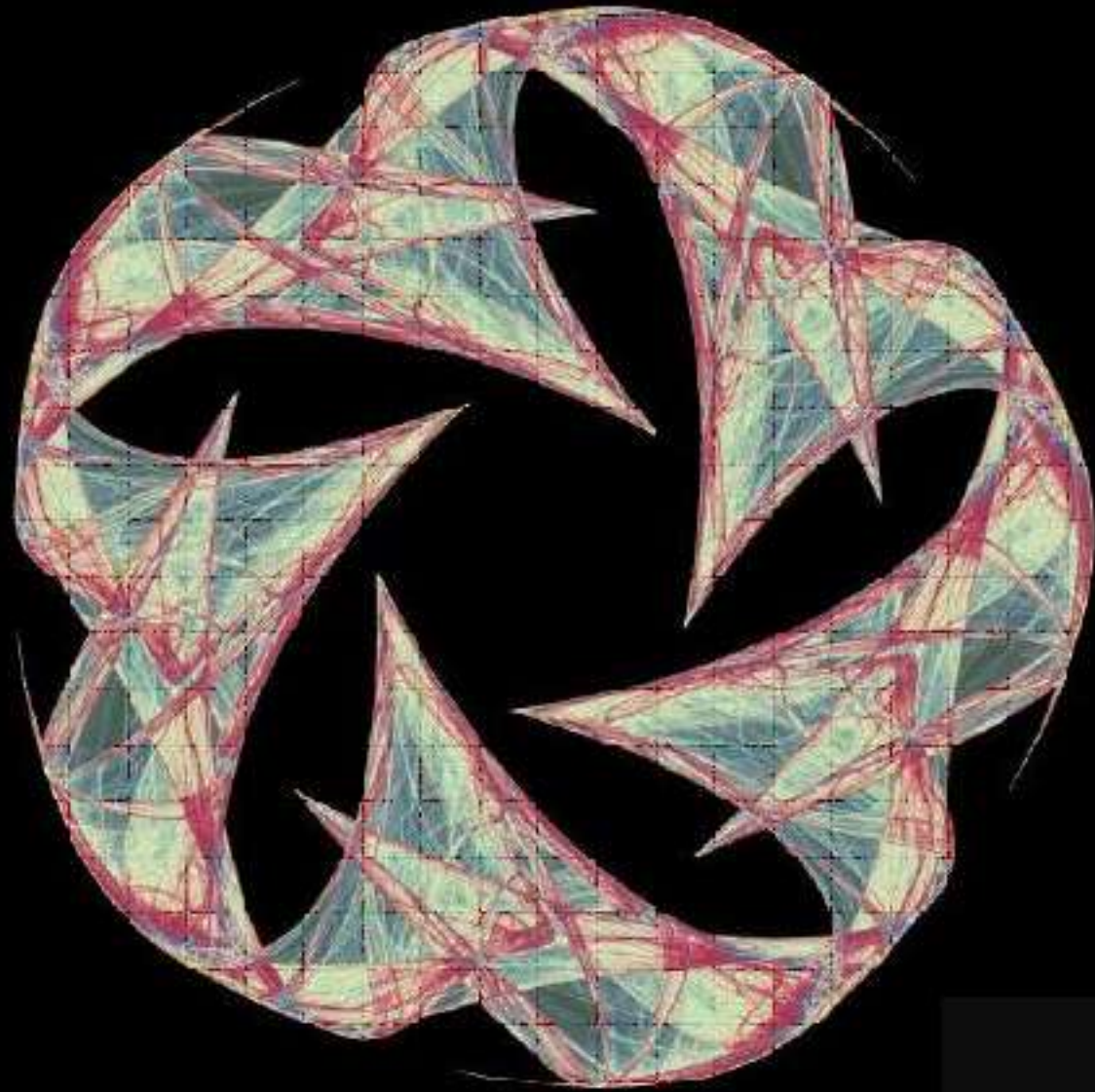



www.polymorf.net

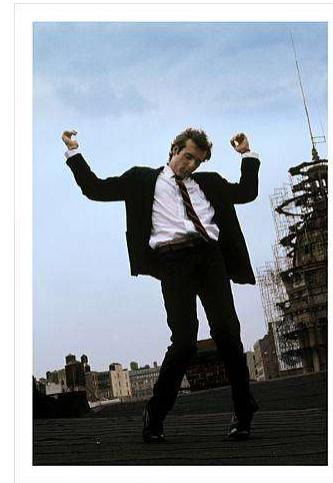
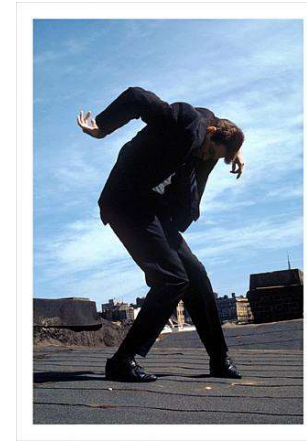



























Will Alshop
, Ontario Art School, 2004

















Photo © The National Gallery, London.





ΙΣΟΡΡΟΠΙΑ



ΣΥΜΜΕΤΡΙΑ

*Στατική
ισορροπία*



ΑΣΥΜΜΕΤΡΙΑ

*Δυναμική
ισορροπία*

Ισορροπία

ΠΑΝΕΠΙΣΤΗΜΙΟ ΔΥΤΙΚΗΣ ΜΑΚΕΔΟΝΙΑΣ
ΤΜΗΜΑ ΕΙΚΑΣΤΙΚΩΝ ΚΑΙ
ΕΦΑΡΜΟΣΜΕΝΩΝ ΤΕΧΝΩΝ

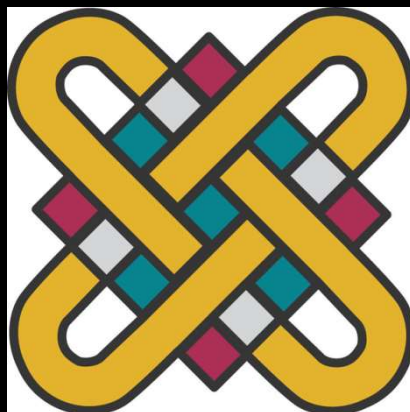

1^ο Εργαστήριο Ζωγραφικής
Κύκλος

Το Χρώμα

Γιάννης Ζιώγας
Αναπληρωτής Καθηγητής